

ONE OPERATION

For Front and Back Deburring, Chamfering,
Countersinking and Drilling.



Made in Switzerland



Our Focus:

Cutting your production costs.

We reduce your process times.

What ultimately counts is your bottom line. Front and back machining of bore edges in ONE OPERATION without having to turn the workpiece will enable you to reduce your production times and eliminate the entire deburring operation outside of the machine.

But there is more: **optimization of process times** is only one element. All our tools are made of hardened tool steel and fitted with exchangeable carbide blades, specifically designed for use on automatic machine tools but can also be operated manually. The coatings and the geometries of the blades are matched to the material that is to be machined. This ensures **extended blade life** and a long life cycle of the tools.

High process capability is the result of reduction to the essentials and of optimizing details. We are constantly developing solutions to make improvements to our tool systems.

Simple tool handling saves money and helps to avoid faulty pre-settings. An example: The changing of a blade by hand in fewer than 5 seconds only – in the machine, without further aids, without pre-settings, without program changes. HEULE makes this possible.

With a **wide range of standard items stocked and ready to ship**, we make sure you have what you need quickly.

Many of our customers have specific needs, so we offer **tools custom-designed** and engineered to solve your unique manufacturing challenges.

What the HEULE name stands for:

- Continuous innovation focused on back bore machining
- Assured quality (ISO 9001)
- Family-based company culture
- Active and applied environmental awareness
- Solid financial management



The Global Leader.

HEULE is the most innovative provider of deburring tools.



Our strength lies in problem solving.

Our innovations revolve exclusively around back bore machining. Since 1961, when HEULE Werkzeug AG was initially set up as a contract manufacturing business, our goal has been to reduce production times. Therefore, we developed tools that can front and back deburr, chamfer and countersink in ONE OPERATION and without turning the workpiece. Today, HEULE achieves 50% of its sales turnover with tools developed to suit individual customer requirements.

According to our founder Heinrich Heule, "The production problems of our customers are our daily bread!": a motivation that reveals the core of HEULE's success. Problem solving has remained the motor of the company until today and you can be certain we will be listening very closely when you explain your requirements. The insights acquired combined with our extensive experience form the basis for our innovative approaches.

A state-of-the-art machine park gives us the flexibility to leave the beaten track to take unconventional approaches. We are committed to the values of quality, precision and service. From all ranks, HEULE's committed and motivated expert staff carry out their work with reliability and professionalism.

Not only our long-serving employees and our partner-based relationships reflect our sustainable way of thinking; we are also strongly committed to the environment. The air conditioning system of our state-of-the-art company building is operated with zero CO₂ emissions.

At first incredulous amazement, now global recognition.

In the early seventies, HEULE struggled for recognition of its tool concept until the acquisition of the first large account, Daimler in Stuttgart.

Today, all major automobile manufactures in Europe, America and Asia take advantage of HEULE's front and back deburring, chamfering and countersinking tools in One Operation.

HEULE tools have also been tested and approved in the aerospace industry by Airbus, Boeing, GE and other manufacturers alike. HEULE tools are used for machining all materials, ranging from aluminum and steel to titanium, Inconel, and other nickel-based alloys.





The HEULE Service.
 We distribute our products worldwide while providing global and competent on-site support.

We give you support on-site in your language.

HEULE continues its global presence and excellent customer service with its subsidiary offices in the United States, China, Korea and Germany. Our experienced distribution partners offer competent technical support to you locally. This is why HEULE Werkzeug AG is the first choice for many world leading manufacturers seeking solutions for back bore machining.

- HEULE Subsidiaries:**
- Loveland/OH, USA
 - Wuxi, China
 - Seoul, South Korea
 - Wangen, Germany
- About 50 authorized sales partners in over 35 countries assure optimal service for our customers on site.

Technically competent advice and support on-site is important to HEULE because HEULE tools are rarely created on a CAD-System in an isolated engineer's office. What is unique about HEULE tools is that they are typically created on the shop floor next to the machine. First, customers describe the new function they wish to implement or the problem they face in the field of machining. Then our specialists listen carefully, applying their extensive know-how to propose possible approaches to a solution.

In this close cooperation, which usually grows over a period of time, an existing tool type is further refined and adapted to the customer's needs. If no tool currently exists to meet these needs, a new tool is developed which optimally meets the customer's specific requirements.

Whatever approach leads to the solution, the goal of the HEULE specialists is always to maximize the customer's productivity on the basis of unrivaled quality.

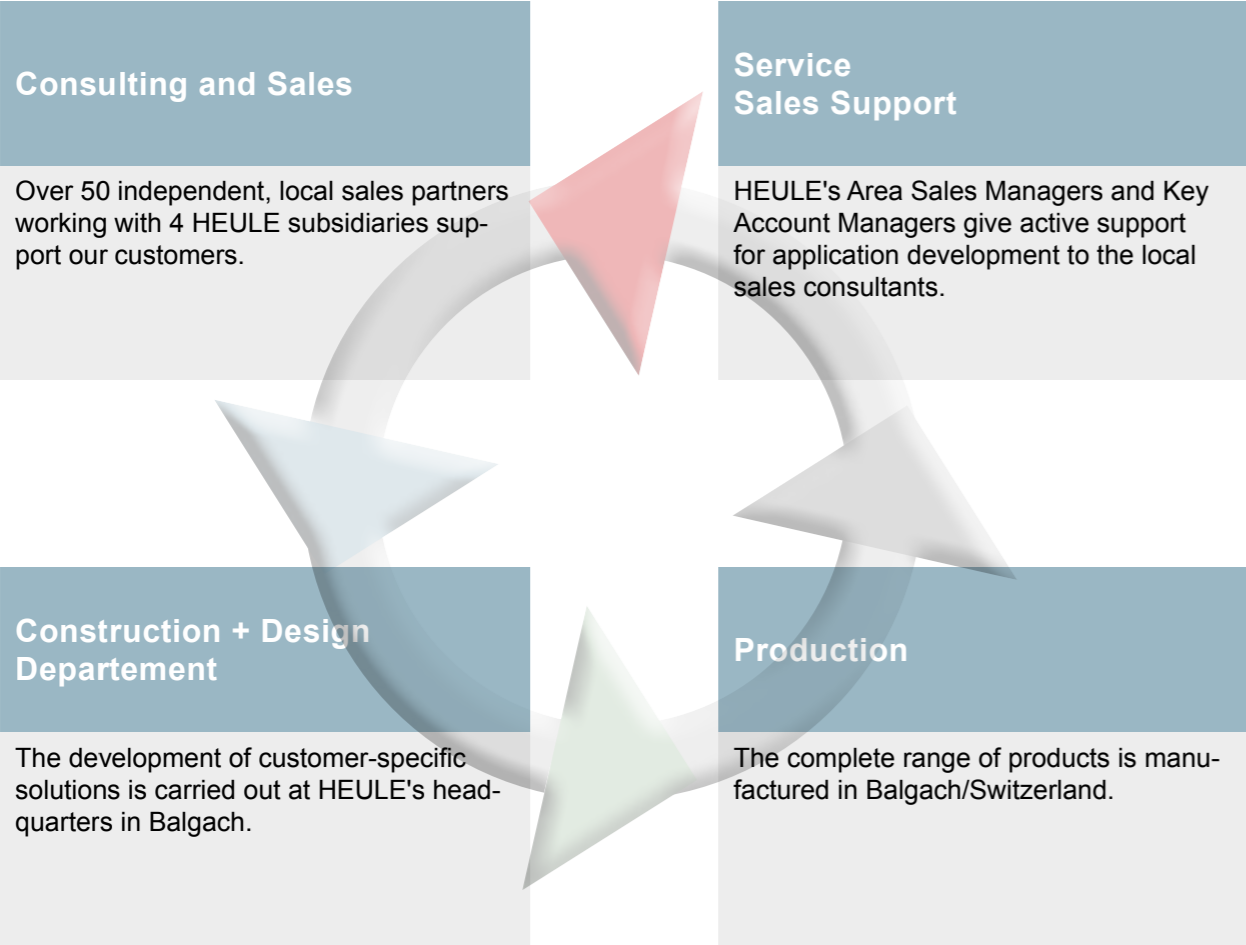



Large production runs
Complex materials



Inaccessible work areas
Oversized workpieces

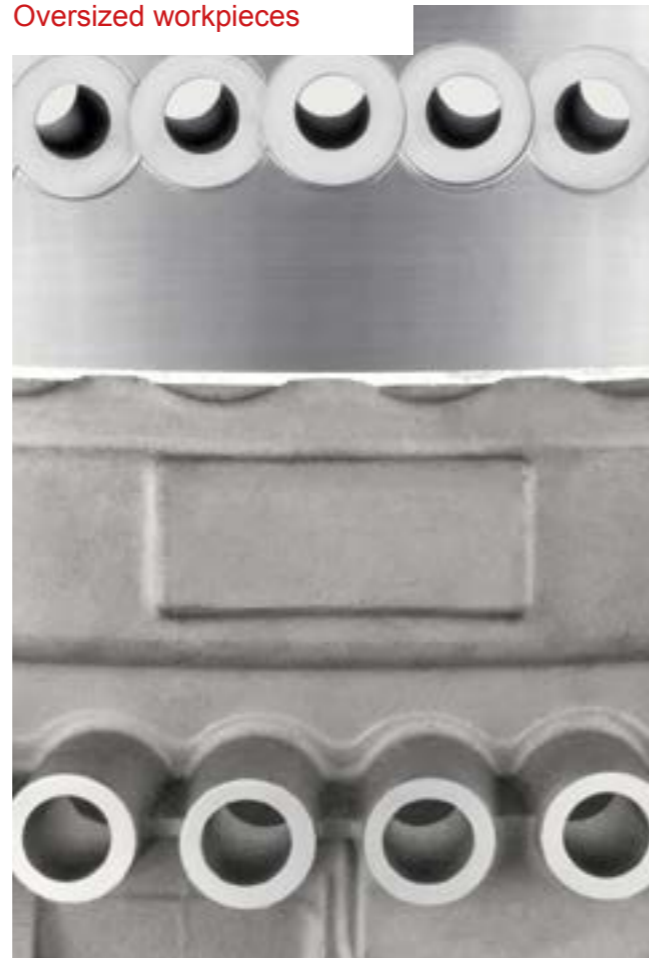

Our Market Expertise.

HEULE tools are used around the world for large production runs, complex materials and oversized workpieces.

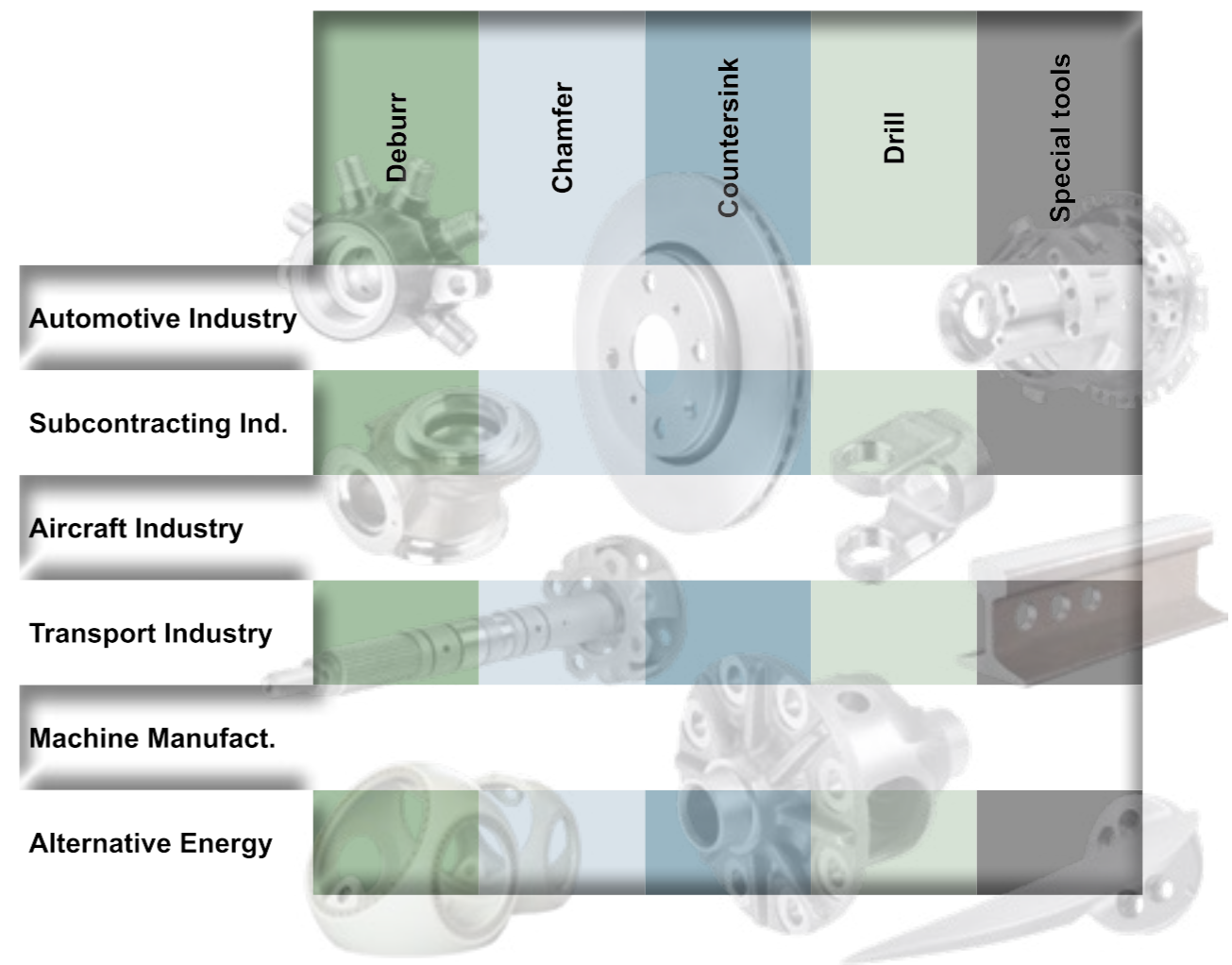

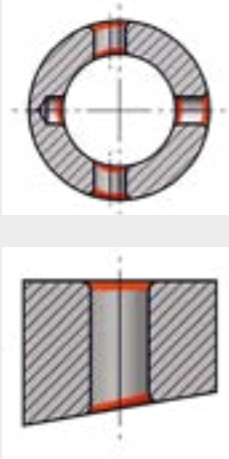
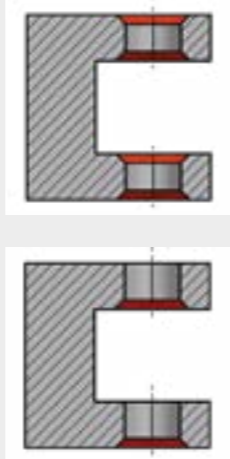
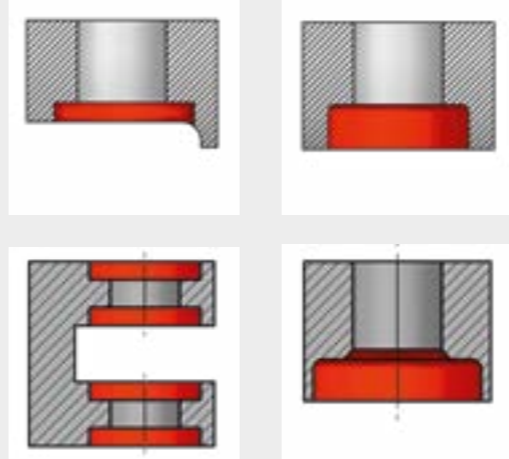
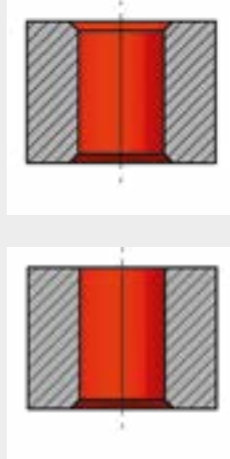

Back Bore Machining: The core focus of our innovations.

	Deburring	Chamfering	Countersinking	Drilling-Chamfering
Application				

	Deburring	Chamfering	Countersinking	Drilling-Chamfering
Characteristics	<p>Removes burrs radially from even and uneven bore edges without requiring the workpiece to be turned. Even bore machining forwards and backwards. Manually as well as automatic operation. High efficiency and process capability.</p> <ul style="list-style-type: none"> ■ Radial deburring of even and uneven bore edges ■ Sloping surfaces of up to 30° max. ■ Typical deburr size of 0.2-1.4 mm ■ Usable for all materials, from aluminium to nickel alloys ■ Available from Ø2.0 mm and larger 	<p>Removes burrs radially from even bore edges without requiring the workpiece to be turned. Even bore machining forwards and backwards. Particularly suitable for automatic operation with high volume. High efficiency and process capability guaranteed.</p> <ul style="list-style-type: none"> ■ Controlled chamfering ■ Machining forwards and backwards ■ Suitable for reamed and readily drilled bores ■ Usable for all materials, from aluminium to nickel alloys ■ Available from Ø2.0 mm and larger 	<p>Countersinks forwards and backwards, or backwards only. Without turning the workpiece.</p> <ul style="list-style-type: none"> ■ Countersinks up to 2.3 x bore diameter ■ Machines all bore edges in a single pass, no need to turn the workpiece ■ Chatter-free sinking ■ Allows interrupted cut ■ High efficiency and process capability 	<p>Efficient drilling combined with front and back chamfering in one single pass.</p> <ul style="list-style-type: none"> ■ For bore depths up to 2 x bore diameter ■ Two operation steps in one tool ■ Easy to exchange drill bit and carbide chamfer blade ■ Short set-up and ancillary times thanks to simple handling

	Deburring tools	Chamfering tools	Countersink / back spotfacing tools	Drill combination tools
Products	<p>COFA – the universal deburring tool</p> <p>X-BORES – deburring technology for extremely intersecting bores and cross bores</p>	<p>SNAP – the efficient chamfering tool</p> <p>DEFA – the chamfering tool for high dimensional accuracy</p>	<p>BSF – the efficient back spotfacing tool</p> <p>SOLO – the automatic front and back counter-boring tool</p> <p>GH-K – the chatter-free front countersinking tool</p>	<p>VEX – the combined drilling and chamfering tool</p>



Our Productivity Boosters.
We increase your efficiency.

COFA – The universal deburring tool

Page 16

Consistent deburring of even and uneven bore edges in **ONE OPERATION**.

- Bore-Ø 2.0 mm to Ø26.0 mm. Bore diameters exceeding Ø26.0 mm are deburred with the cassette tool system
- Carbide blades with material dependent coatings
- Radial and consistent deburring of even and uneven bore edges
- Tool types C6 up to C12 allow up to three different deburring capacities due to exchangeable blade sizes
- Does not create any secondary burrs

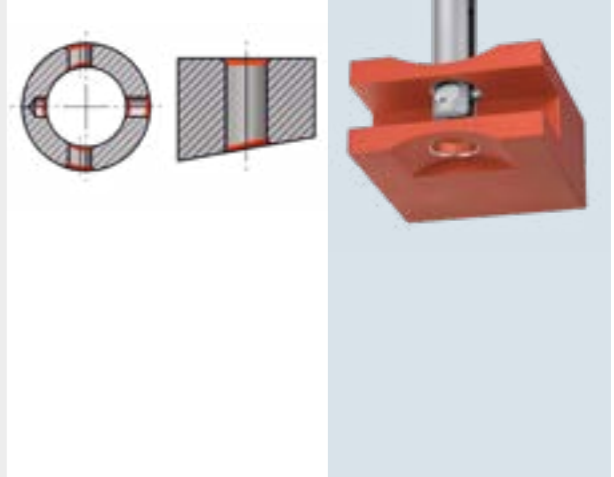

SNAP – The economic chamfering tool

Page 58

Economic front and back chamfering in one single pass with easy blade changes.

- Bore-Ø 2.0 mm to Ø35.0 mm. Bore diameters exceeding Ø35.0 mm are deburred with the cassette tool system
- Front and back chamfering of bore edges in one single pass
- Carbide blades with material-dependent coatings
- Simple handling and high process capability
- No harm to the bore surface when traversing the bore

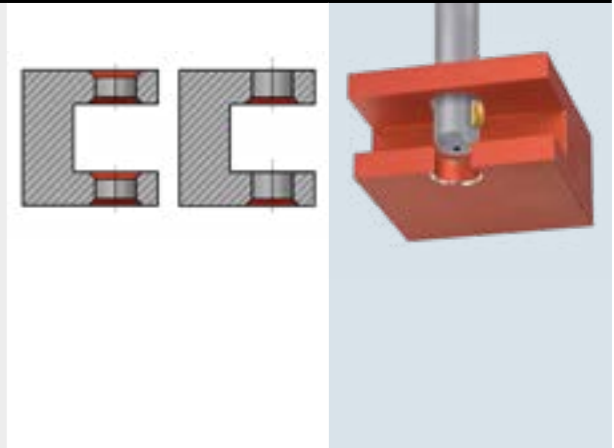



Most Reliable.

High process capability is the result of reduction to the essential and optimization of details.

BSF – the competitive back spotfacing and counterboring tool

Page 130

Back spotfacing up to 2.3 x bore diameter.

- Standard range in steps of 0.5 mm from bore-Ø 6.5 mm up to 21.0 mm
- Designed for automatic operation and ready for service immediately
- Works without an anti-rotation device, change of spindle direction, or contact device
- Suitable for vertical and horizontal operation
- Blades are made in carbide with different coatings

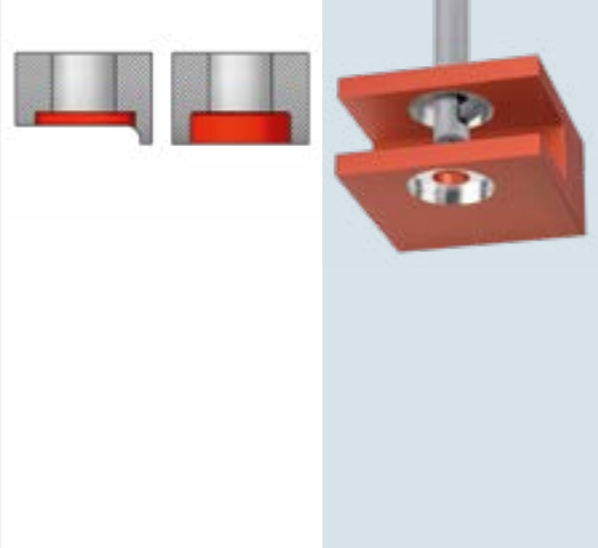

SOLO – the independent spotfacing and counterboring tool

Page 182

Machine independent back spotfacing and formsinking tool, front and back in **ONE** OPERATION.

- Automatic front and back or back-only spotfacing and formsinking without any need to turn the work-piece.
- Individual design assures highest process capability and performance
- Extremely robust tool system
- Manually and easily exchangeable carbide blades
- Without any anti-rotation device or other machine adaptations - immediately ready for service

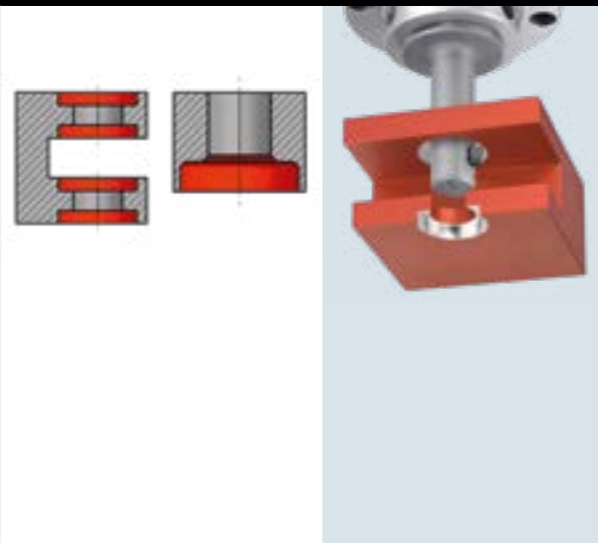

GH-K – the chatter-free countersinking tool

Page 202

Chatter-free front countersinking of a wide countersink range with one single tool

- Wide countersinking range from bore-Ø 3.0 mm to Ø25.0 mm, or Ø4.0 mm to 45.0 mm with one tool
- For chatter-free countersinking and circular interpolation milling
- Exchangeable and regrindable carbide blades
- Tools for 60° and 90° countersinks

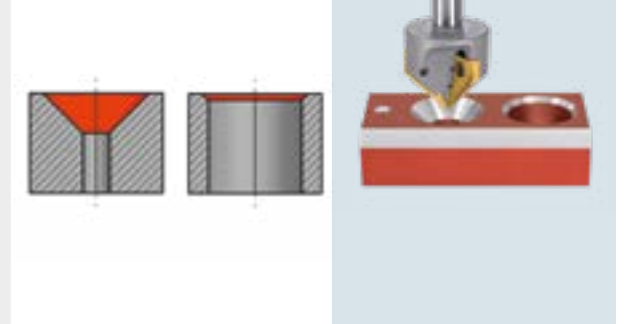

VEX – the combined drilling and chamfering tool

Page 210

Competitive drilling with front and back chamfering in **ONE** OPERATION.

- For bores from Ø5.0 mm to Ø17.0 mm and bore depths up to 2 x d
- Reduction of cycle times by executing two operation steps in one single pass
- Easy to exchange drill-bit
- Quickly exchangeable carbide chamfer blades
- Short set-up and ancillary times, thanks to simple handling

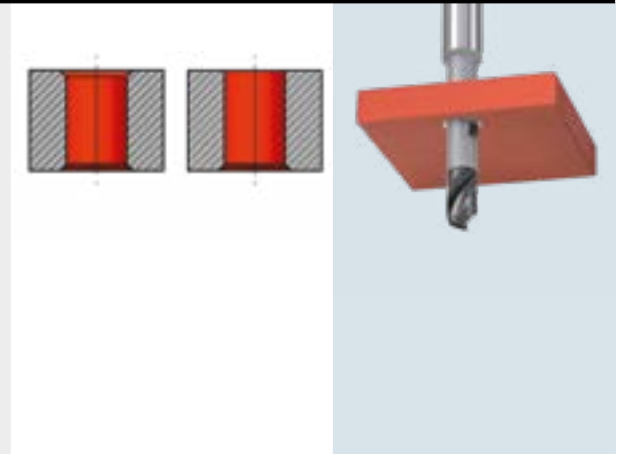

DEFA – the chamfering tool for high dimensional accuracy

Page 106

Adjustable chamfering of interrupted bore edges front and back in **ONE** OPERATION

- Simple on-tool adjustment to the required chamfer size, depending on the bore dimension from 0.1 mm to 2.0 mm
- Two-edged tool for precise chamfer-Ø dimension and for high-quality chamfer surfaces
- Exchangeable carbide blades

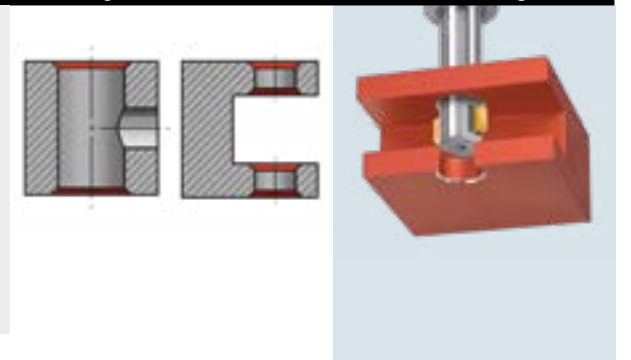



COFA Online Information



Product Video

www.heule.com/en/deburring/cofa



Case Studies

[www.heule.com/en/case-studies/
?t=99](http://www.heule.com/en/case-studies/?t=99)



COFA Tool Selector

www.heule.com/en/cofa-tool-selector



Contact Sales Represent.

www.heule.com/en/contact-sales-representatives



Request for Quote Form

www.heule.com/en/request-for-quote/



Manual

[www.heule.com/en/service/manual/
cofa](http://www.heule.com/en/service/manual/cofa)



COFA

Consistent deburring of even and uneven bore edges, front and back in one operation.

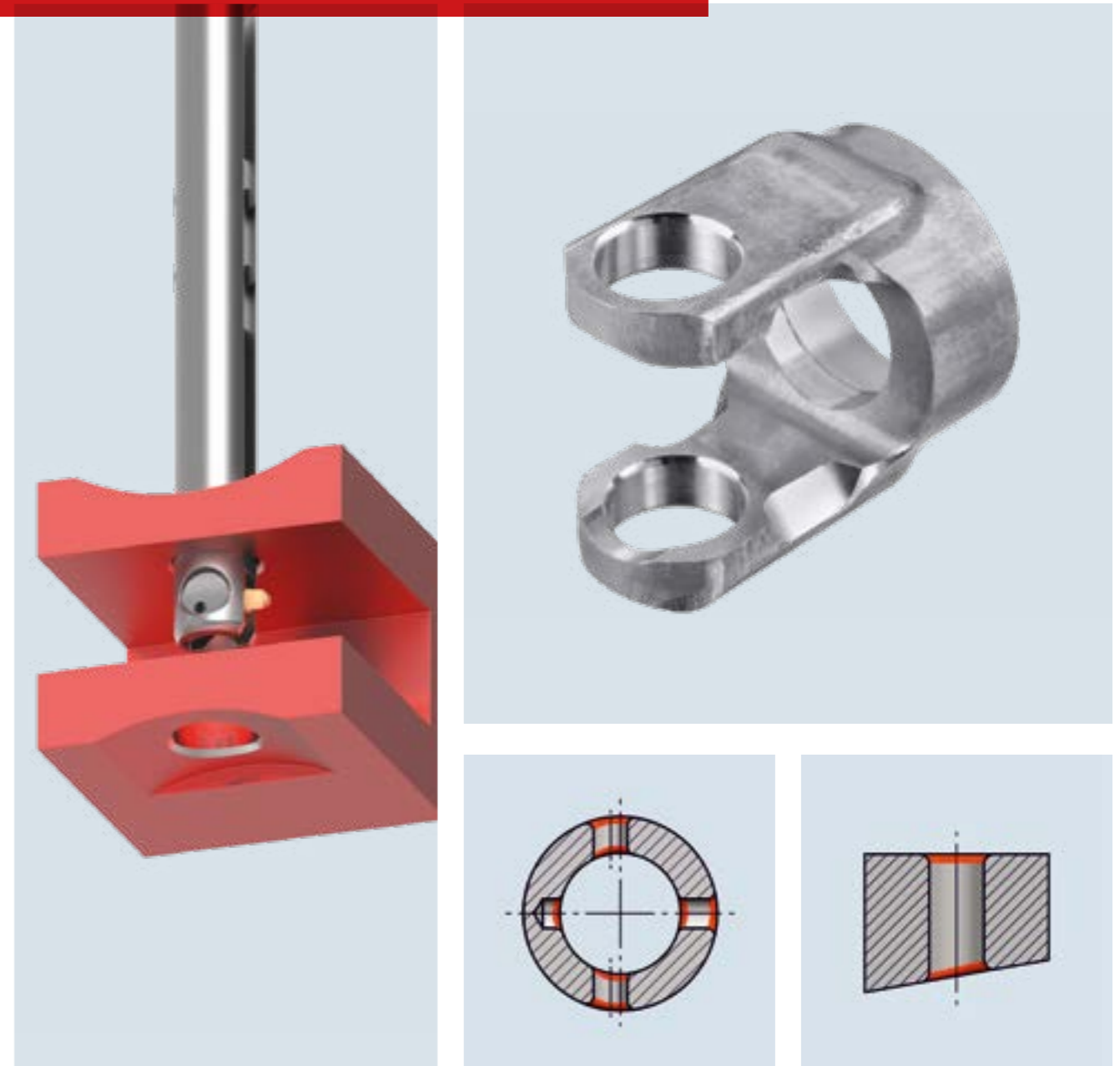



COFA – The Universal Deburring Tool



Consistent front and back deburring of even and uneven bore edges, in ONE OPERATION

COFA is the first and unrivaled tool system that removes burrs on the front and back of a drilled through-hole on even and uneven surfaces in a single cycle. It radially removes the burrs off the bore edges, without requiring the workpiece to be turned or the spindle stopped.

It is built for high volume production in CNC machines but can also be used for manual operation. The proven advanced system assures high efficiency and the required process capability.

COFA

Characteristics and Advantages

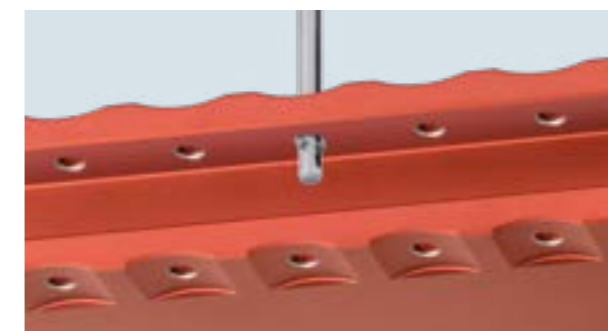

- The COFA standard tool series ranges from bore diameter 2.0 mm up to 26.0 mm. The cassette system is designed for bore diameters larger than 26.0 mm.

- As the developer and manufacturer of this tool system, HEULE is able to provide also tailor-made solutions for specific applications.



- The exchangeable carbide blades are carried out with material dependent coatings.

- Tool types C6 up to C12 allow up to three different deburring capacities without changing the tool due to the exchangeable blade sizes.

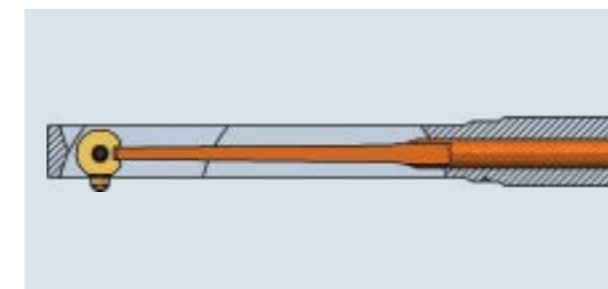

- Combining the simple functioning principle with the robust construction method guarantees a safe and reliable process.

- Another important advantage of this function principle is the strict absence of secondary burrs.



- In order to achieve a high process capability important components such as a blade holder and tool body have been designed for maximum life and stable cycle times.



- The COFA system guarantees a consistent, radially shaped deburring of even and uneven bore edges.

- No matter what the thickness of the workpiece is, the deburring capacity always remains the same.



- The cassette solution integrates the deburring process into an existing customer tool. By combining two or several processes in one single tool, the cycle time can be reduced considerably.

- The cassette expands the maximum diameter of still machinable bore edges without limits.



- The ball shape of the blade protects the bore surface from damage when traversing the bore.

- The tolerance and the roughness of reamed bores remain unchanged.



- The thread tool series has been optimized for easy center positioning of the screws.

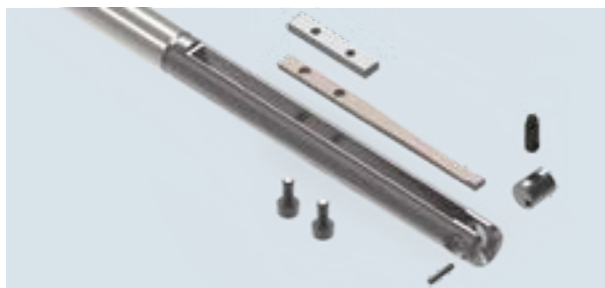

- The simple tool design allows fast and safe maintenance.

COFA has been specifically designed for front and back deburring on even and uneven bore edges, in one single pass. It radially removes the burrs off the bore edges. Independent of the Z-position of the workpiece, the deburring capacity of the tool does not vary.

The tool concept is suitable for soft as well as difficult to machine materials. This is done

without the need for preadjustments. The blades are made out of coated carbide and guarantee a long tool life. They are exchangeable according to the required deburring capacity.

Typical applications are forks, common rails, castings, tubes with cross bores and other workpieces with cross bores in main bores.

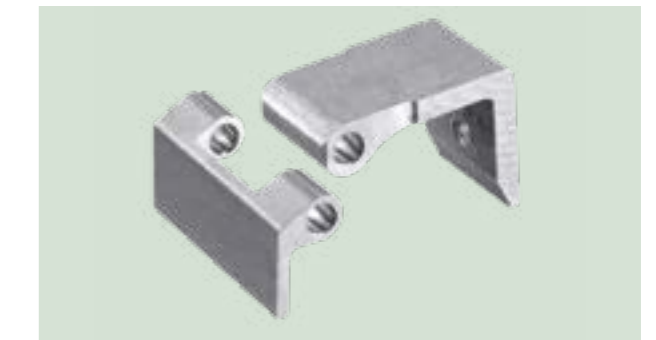
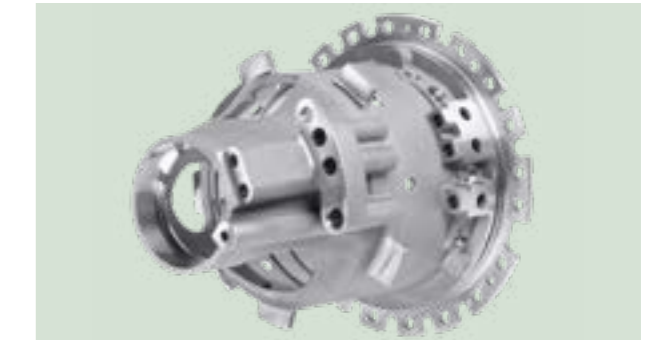

Tool Description

The COFA tool family consists of three different groups of tool types. It starts with COFA C2 and C3, followed by COFA 4M and 5M in the intermediate segment. COFA *New Generation* C6, C8 and C12 representing the upper end of the range is the latest development. The illustration COFA C2 shows the real dimensions of the tool.

The concepts differ because of the different tool dimensions. Whereas the blade and the blade holder form a unit in COFA C2/C3 and 4M/5M which is held in the tool body by a rollpin, it has been split into two separate components in COFA *New Generation*.

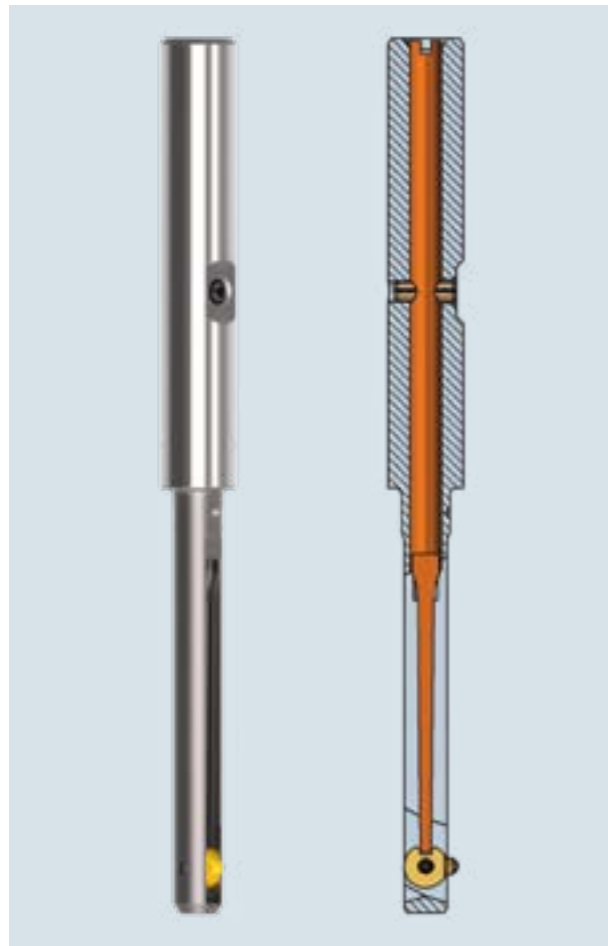

Image: COFA 4M

The design principle of the single-piece blade has been in use successfully for decades. The *New Generation* design of the larger tools consists of an independent blade that is fit into a more rigidly guided blade holder. This increases the already long tool life as well as the process capability.

The blade itself needs less material and can be exchanged fast and easily. The different blade sizes available for the same tool allow to apply different deburring capacities.

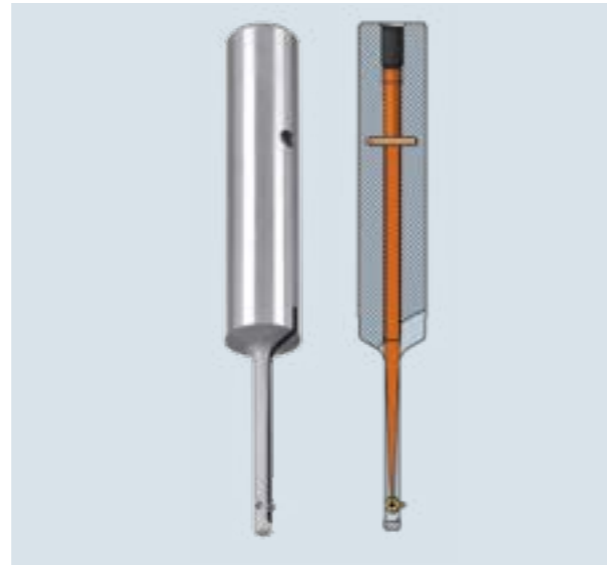

Image: COFA C2

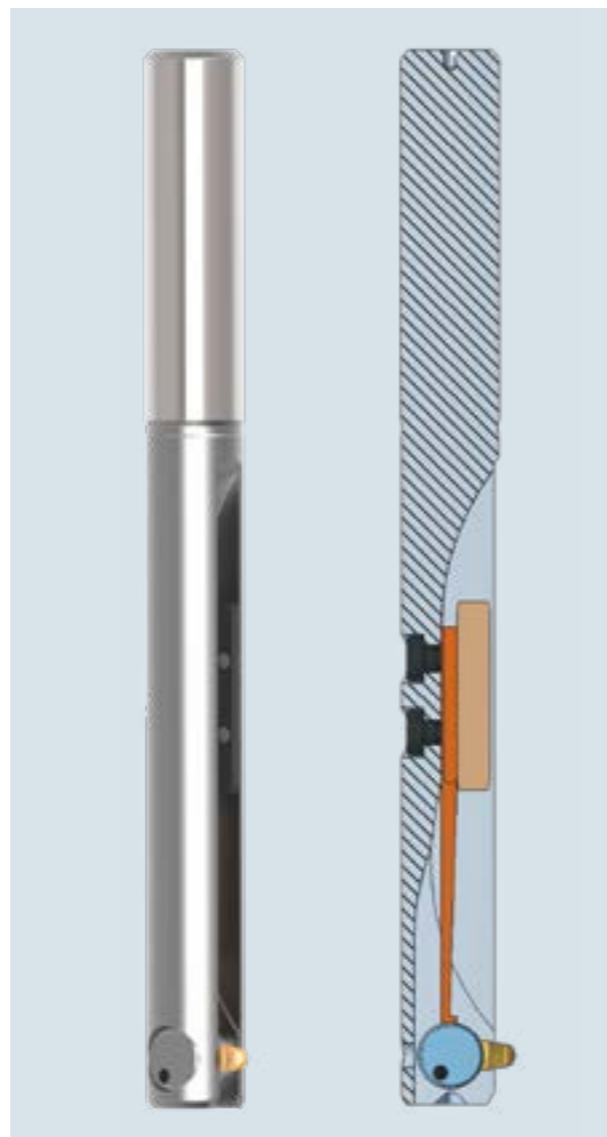
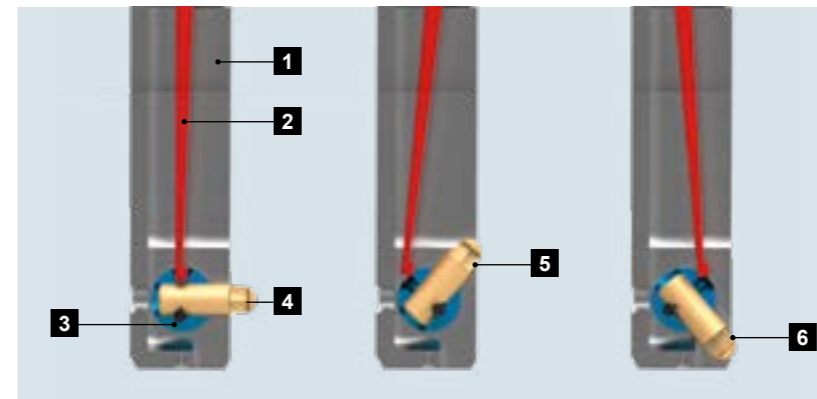

Image: COFA C12

Function Principle



- 1 Tool body
- 2 Spring
- 3 Blade holder
- 4 Blade Type C6 - C12
- 5 Cutting edge forward
- 6 Cutting edge backward

The COFA blade is mounted spring-loaded in the tool body. In COFA C2 to 5M, the swivel movement is guided by a rollpin, whereas it is a blade holder for COFA C6 to C12 (illustrated above). This way, the cutting edge follows the uneven bore edge. The more the tool enters into the to bore, the more the blade swings into the tool body. The result is a radially shaped consistent deburring of the bore edge.

Process Steps Description

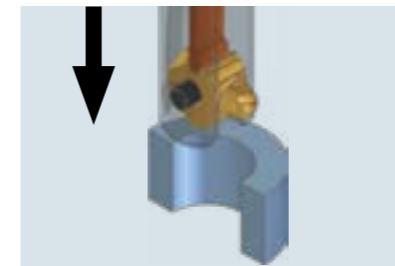

The process is very simple. First, rapid traverse of the cutting unit of the tool above the top material surface of hole or burr. Referencing the front edge of the cutting blade.

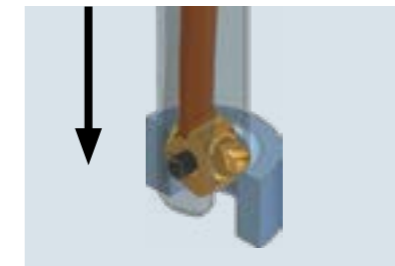

In working feed forward and working speed, the deburring of the upper bore edge is carried out.

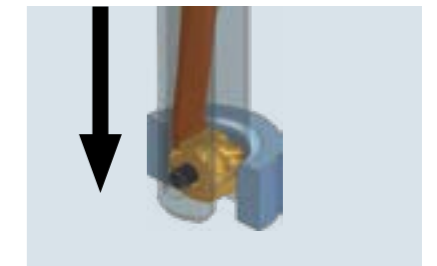

Once deburring is complete, traverse in rapid feed without stopping the spindle. Pay attention to interfering edges in the interior (i.e. cross bore, groove).

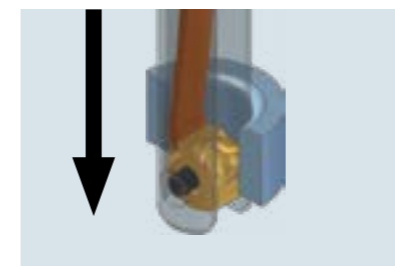

Despite of the swivel movement of the spindle, the ball shaped blade head glides softly on the surface without any damage.



As soon as the blade swings out again at the back side of the work piece, the rapid feed is stopped.

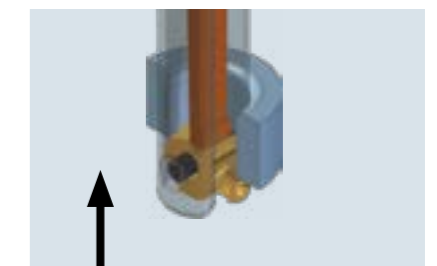

In working feed, the deburring of the back bore edge is carried out. Once finished, traverse in rapid speed and without stopping the spindle, out of the hole.

COFA Range Summary

The product range comprises tools for the use in bore diameters ranging from 2.0 mm to 26.0 mm. In addition, using cassettes, any size of bore diameter can be deburred. The deburring capacity (radially) is 0.1 mm up to 1.4 mm maximum depending on

bore dimension and blade selection. Within the tool range, there are variants of diameters that cover a minimal bore diameter range.



Bore	Max. Deburring Capacity ¹	Tool Series
Ø 2.0 – Ø 3.1 mm	0.15 mm	COFA C2
Ø 3.0 – Ø 4.1 mm	0.25 mm	COFA C3
Ø 4.0 – Ø 5.0 mm	0.25 mm	COFA 4M
Ø 5.0 – Ø 6.0 mm	0.35 mm	COFA 5M
Ø 6.0 – Ø 8.4 mm	0.70 mm	COFA C6
Ø 8.0 – Ø 12.4 mm	0.90 mm	COFA C8
Ø 12.0 – Ø 26.0 mm	1.40 mm	COFA C12
from Ø 10.0 mm	0.70 mm	COFA C6 Cassette
from Ø 14.0 mm	0.90 mm	COFA C8 Cassette
from Ø 20.0 mm	1.40 mm	COFA C12 Cassette
Thread M10 Ø8.5 mm	10.40 mm	COFA C8/M10
Thread M12 Ø10.2 mm	12.20 mm	COFA C8/M12
Thread M16 Ø 14.0 mm	16.80 mm	COFA C12/M16
Thread M20 Ø17.5 mm	20.40 mm	COFA C12/M20
Thread M8 Ø6.8 mm	8.50 mm	COFA C6/M8

¹ The deburring result differs due to material, cutting data and application. The value listed is the maximum that is theoretically achievable. The spring has to be selected accordingly.

Part No.: Tool including standard blade

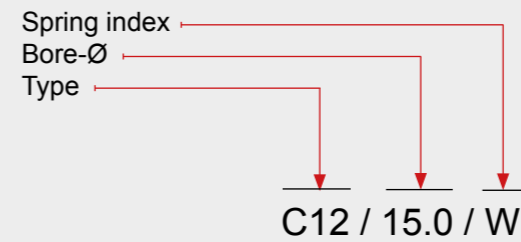

Part No.: Tool **without** blade

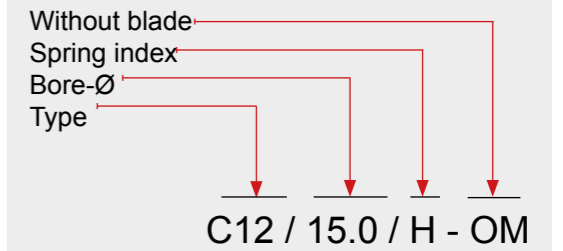

Tool type

Within a tool type there are different tool sizes available. The tool types C2/C3/4M/5M have the same blade size within the own line. The types C6/C8/C12 house two blade sizes (M, L) each. The cassette tools use the standard blades. The tool series for threads however houses special blade sizes.

Tool size

The tool size is defined by the bore diameter. Tool diameter and deburring capacity are shown in the tables.

If a tool is used in a larger bore than indicated by the tool size, a correspondingly smaller deburred area results due to the given deburr diameter of a tool size. This is acceptable in most cases or even sometimes desirable.

Spring index

Depending on the material to be machined, the tools are available with different spring loads. The tools can be equipped with a different spring by a simple exchange operation.

Clamping system

As standard, all tools will be manufactured with a cylindrical shank. Weldon / Whistle Notch clamping systems can be produced upon request. They are not available from stock.

- HB = Weldon
- HE = Whistle Notch

Order Example:
COFAC12/15.0/H-HB-OM

Without special designation the tool will be supplied with the standard blade built in as defined per type series. This is the M type blade for tool types C6 up to C12. If a special blade is needed - i.e only backward cutting - the tool has to be ordered **without** blade (add extension "OM") and order the special blade separately (see tool order example C6 to C12 on page 25).

Coating blades

All COFA blades are made of carbide. The three available coatings are:
T: Steel, titanium, Inconel (standard)
D: Aluminium alloys
A: For increased requirements

Order Example COFA C2/C3

Requirements: Deburr bore, no defined chamfer
Bore-Ø: 2.6 mm
Material: Cast
Selection:
Tool: Part No. C2/2.6/H
Deburr-Ø: 3.1 mm
Blade: Standard Blade

Order Example COFA C6/C8/C12

Requirements: Deburr hole, Ø9.5 mm minimum
Bore-Ø: 8.4 mm
Material: Titanium
Selection:
Tool: Part No. C8/8.4/Z-OM
Spring type: Z for titanium
Blade: Part No. C8-M-0001-T

Recommendation

Select the tool size so that the resulting chamfer will be **just as large as requested** and not as large as possible.

COFA C2 Tool Ø 2.0 mm to 3.1 mm

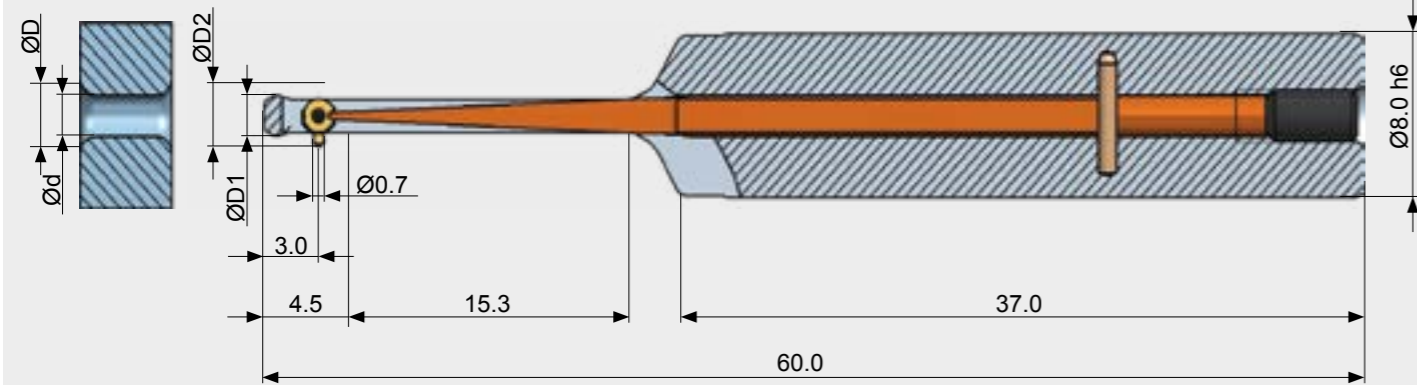

Tool Table

Bore-Ø d	Debur-Ø max. ¹ D	Tool-Ø D1	Maximum-Ø ² D2	Tool with Standard Blade	
				Part No.	Spring index
2.0	2.2	1.95	2.7	C2/2.0/ ...	Please add the spring index after the Part Number! Order example: C2/2.8/W Refer to spring index on page 27
2.1	2.3	2.05	2.8	C2/2.1/ ...	
2.2	2.4	2.15	2.9	C2/2.2/ ...	
2.3	2.5	2.25	3.0	C2/2.3/ ...	
2.4	2.6	2.35	3.1	C2/2.4/ ...	
2.5	2.7	2.45	3.2	C2/2.5/ ...	
2.6	2.8	2.55	3.3	C2/2.6/ ...	
2.7	2.9	2.65	3.4	C2/2.7/ ...	
2.8	3.0	2.75	3.5	C2/2.8/ ...	
2.9	3.1	2.85	3.6	C2/2.9/ ...	
3.0	3.2	2.95	3.7	C2/3.0/ ...	
3.1	3.3	3.05	3.8	C2/3.1/ ...	

¹⁾ The deburring result varies depending on material, cutting data and application. The indicated dimension is the theoretically possible maximum. The spring has to be selected accordingly.

²⁾ Pay attention to the interfering edges.

ORDERING INFORMATION

Is the tool part number written without the extension "OM" (= without blade), the standard blade C2-M-0006-A is already mounted. Please refer to the explanations on page 25.

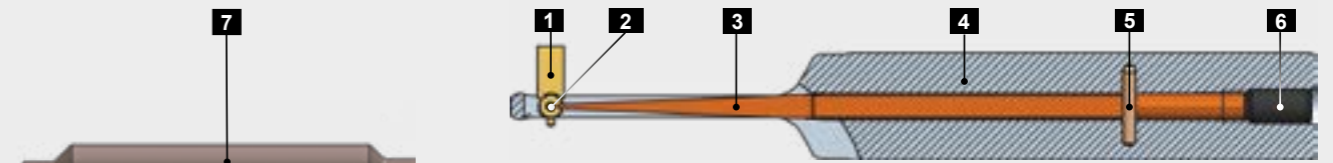

Spare Parts

Pos.	Description	Part No.
1	COFA C2 Blade	see below
2	Roll pin Ø0.7x1.7	C2-E-0002
3	Bending spring	see below
4	Tool body	upon request
5	Locking pin Ø1.0m6x6	GH-H-S-1017
6	Threaded pin M2.5x5	GH-H-S-0135
7	Assembly pin	C2-V-0001
	Allen wrench for pos. 6	GH-H-S-2106

Spring Index

Type	Bending spring	Part No.	Application
W2	soft (softer than W1)	C2-E-0011	Special applications
W1	soft (softer than W)	C2-E-0012	Special applications
W	soft	C2-E-0013	Aluminium alloys, copper zinc alloys, soft mat.
H	hard	C2-E-0014*	Standard applications, all steel types
S	super hard	C2-E-0015	Hard and tough materials
Z	extra hard (harder > Z)	C2-E-0016	Very tough materials or very large burr formations
Z1	extra hard (harder > Z1)	C2-E-0017	Special applications

Blades

Angle	Part No. forward and backward cutting		Part No. backward cutting only	
	Coating A	Coating D	Coating A	Coating D
10°	C2-M-0007-A	C2-M-0007-D	C2-M-0017-A	C2-M-0017-D
20°	C2-M-0006-A*	C2-M-0006-D	C2-M-0016-A	C2-M-0016-D
25°	C2-M-0008-A	C2-M-0008-D	C2-M-0018-A	C2-M-0018-D
30°	C2-M-0009-A	C2-M-0009-D	C2-M-0019-A	C2-M-0019-D

*Standard items / Please enquire about stock or delivery times for all non-standard blades.

Explanations to coatings (see on page 25)

A: Coating for steel, titanium, Inconel
D: Coating for aluminium alloys only

COFA C3 Tool Ø 3.0 mm to 4.1 mm

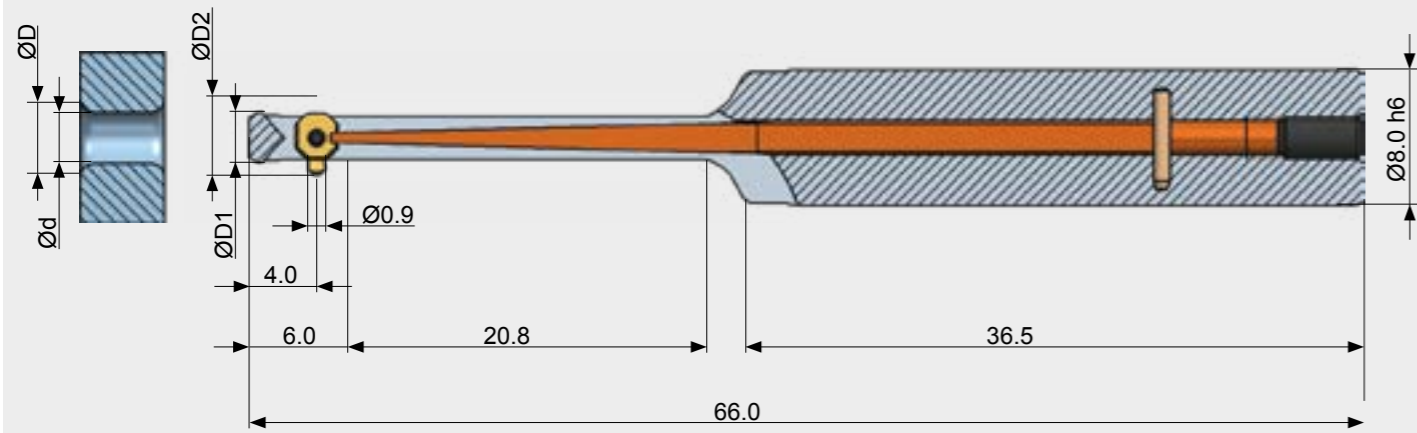

Tool Table

Bore-Ø d	Debur-Ø max. ¹ D	Tool-Ø D1	Maximum-Ø ² D2	Tool with Standard Blade	
				Part No.	Spring index
3.0	3.3	2.95	4.0	C3/3.0/ ...	Please add the spring index after the part no.! Order example: C3 / 3.2 / Z Refer to spring index on page 29
3.1	3.4	3.05	4.1	C3/3.1/ ...	
3.2	3.5	3.15	4.2	C3/3.2/ ...	
3.3	3.6	3.25	4.3	C3/3.3/ ...	
3.4	3.7	3.35	4.4	C3/3.4/ ...	
3.5	3.8	3.45	4.5	C3/3.5/ ...	
3.6	3.9	3.55	4.6	C3/3.6/ ...	
3.7	4.0	3.65	4.7	C3/3.7/ ...	
3.8	4.1	3.75	4.8	C3/3.8/ ...	
3.9	4.2	3.85	4.9	C3/3.9/ ...	
4.0	4.3	3.95	5.0	C3/4.0/ ...	
4.1	4.4	4.05	5.1	C3/4.1/ ...	

¹⁾ The deburring result varies depending on material, cutting data and application. The indicated dimension is the theoretically possible maximum. The spring has to be selected accordingly.

²⁾ Pay attention to the interfering edges.

ORDERING INFORMATION

Is the tool part number written without the extension "OM" (= without blade), the standard blade C3-M-0006-A is already mounted. Please refer to the explanations on page 25.

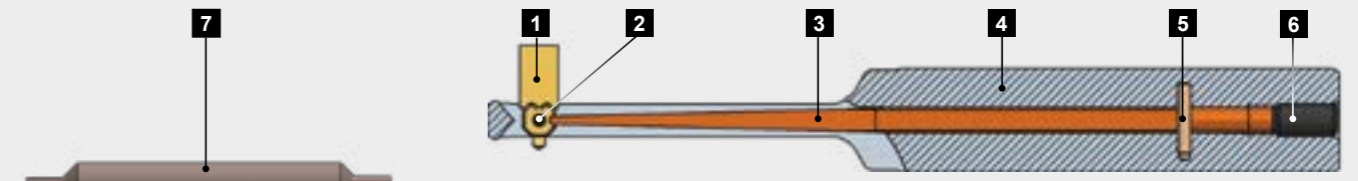

Spare Parts

Pos.	Description	Part No.
1	COFA C3 blade	see below
2	Roll pin Ø1.0x2.7	C3-E-0002
3	Bending spring	see below
4	Tool body	upon request
5	Locking pin Ø1.0m6x6	GH-H-S-1017
6	Threaded pin M2.5x5	GH-H-S-0135
7	Assembly pin	C3-V-0001
	Allen wrench for pos. 6	GH-H-S-2106

Spring Index

Type	Bending spring	Part No.	Application
W2	soft (softer than W1)	C3-E-0011	Special applications
W1	soft (softer than als W)	C3-E-0012	Special applications
W	soft	C3-E-0013	Aluminium alloys, copper tin alloys, soft materials
H	hard	C3-E-0014*	Standard applications, all steel types
S	super hard	C3-E-0015	Hard and tough materials
Z	extra hard (harder > S)	C3-E-0016	Very tough materials or very large burr formations
Z1	extra hard (harder > Z)	C3-E-0017	Special applications

Blades

Angle	Part No. forward and backward cutting		Part No. backward cutting only	
	Coating A	Coating D	Coating A	Coating D
10°	C3-M-0007-A	C3-M-0007-D	C3-M-0017-A	C3-M-0017-D
20°	C3-M-0006-A*	C3-M-0006-D	C3-M-0016-A	C3-M-0016-D
25°	C3-M-0008-A	C3-M-0008-D	C3-M-0018-A	C3-M-0018-D
30°	C3-M-0009-A	C3-M-0009-D	C3-M-0019-A	C3-M-0019-D

*Standard items / Please enquire about stock or delivery times for all non-standard blades.

Explanations to coatings: (see page 25)

A: Coating for steel, titanium, Inconel
D: Coating for aluminium alloys only

COFA 4M Tool Ø 4.0 mm to 5.1 mm

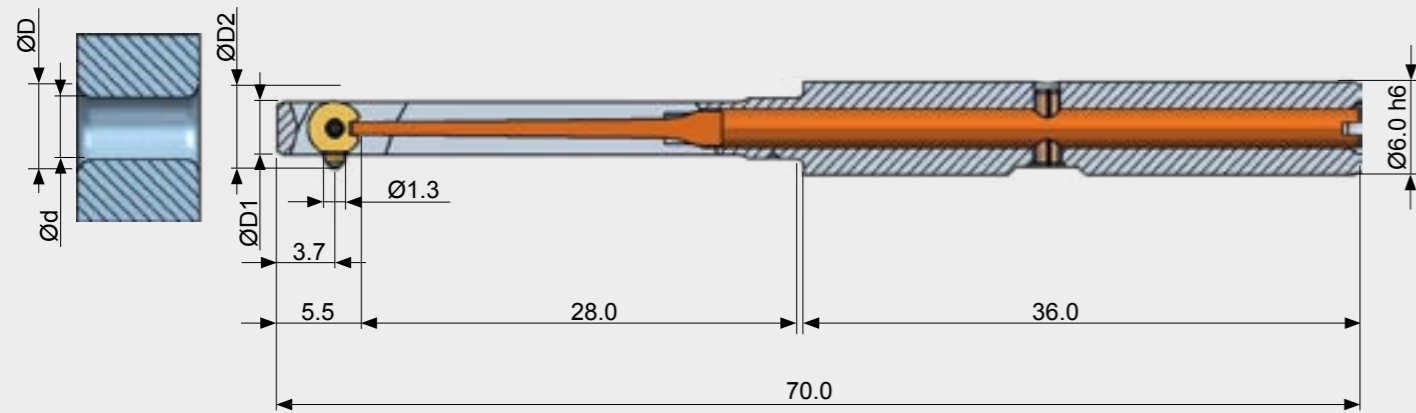

Tool Table

Bore-Ø d	Debur-Ø max. ¹ D	Tool-Ø D1	Maximum-Ø ² D2	Tool with Standard Blade	
				Part No.	Spring index
4.0 - 4.1	4.5	3.9	5.2	COFA4M/4.0/ ...	Please add the spring index after the part no.! Order example: COFA4M/4.2/S Refer to spring index on page 31
4.1 - 4.2	4.6	4.0	5.3	COFA4M/4.1/ ...	
4.2 - 4.3	4.7	4.1	5.4	COFA4M/4.2/ ...	
4.3 - 4.4	4.8	4.2	5.5	COFA4M/4.3/ ...	
4.4 - 4.5	4.9	4.3	5.6	COFA4M/4.4/ ...	
4.5 - 4.6	5.0	4.4	5.7	COFA4M/4.5/ ...	
4.6 - 4.7	5.1	4.5	5.8	COFA4M/4.6/ ...	
4.7 - 4.8	5.2	4.6	5.9	COFA4M/4.7/ ...	
4.8 - 4.9	5.3	4.7	6.0	COFA4M/4.8/ ...	
4.9 - 5.0	5.4	4.8	6.1	COFA4M/4.9/ ...	
5.0 - 5.1	5.5	4.9	6.2	COFA4M/5.0/ ...	

¹⁾ The deburring result varies depending on material, cutting data and application. The indicated dimension is the theoretically possible maximum. The spring has to be selected accordingly.

²⁾ Pay attention to the interfering edges.

ORDERING INFORMATION

Is the tool part number written without the extension "OM" (= without blade), the standard blade GH-C-M-0504 is already mounted. Please refer to the explanations on page 25.

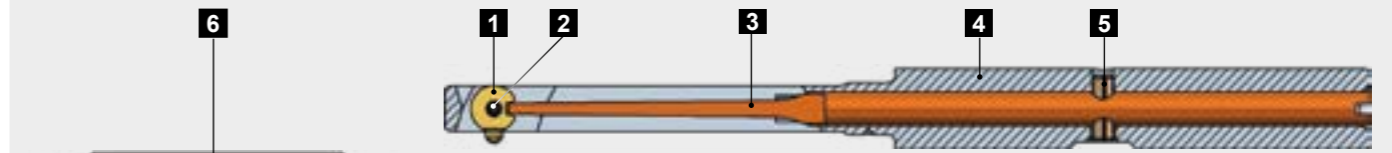

Spare Parts

Pos.	Description	Part No.
1	COFA 4M Blade	see below
2	Roll pin Ø1.0x3.8	GH-C-E-0819
3	Bending spring	see below
4	Tool body	upon request
5	Roll pin Ø1.5x5.0	GH-H-S-0902
6	Assembly pin	GH-C-V-0206

Spring Index

Type	Bending spring	Part No.	Application
W2	soft (softer than W1)	GH-C-E-0341	Special applications
W1	soft (softer than W)	GH-C-E-0340	Special applications
W	soft	GH-C-E-0342	Aluminium alloys, copper zinc alloys, soft mat.
H	hard	GH-C-E-0343*	Standard applications, all steel types
S	super hard	GH-C-E-0344	Hard and tough materials
Z	extra hard (harder > S)	GH-C-E-0345	Very tough materials or very large burr formations
Z1	extra hard (harder > Z)	GH-C-E-0346	Special applications
Z2	extra hard (harder > Z1)	GH-C-E-0347	Special applications
Z3	extra hard (harder > Z2)	GH-C-E-0348	Special applications

Blades

Angle	Part No. forward and backward cutting		Part No. backward cutting only	
	Coating T	Coating D	Coating T	Coating D
10°	GH-C-M-0704	GH-C-M-0784	GH-C-M-0814	GH-C-M-0894
20°	GH-C-M-0504*	GH-C-M-0584	GH-C-M-0914	GH-C-M-0994
25°	GH-C-M-0161	---	GH-C-M-0181	---
30°	GH-C-M-0148	---	GH-C-M-0182	---

*Standard items / Please enquire about stock or delivery times for all non-standard blades.

Explanations to coatings (see page 25)

T: Coating for steel, titanium, Inconel

D: Coating for aluminium alloys only

COFA 5M Tool Ø 5.0 mm to 6.1 mm

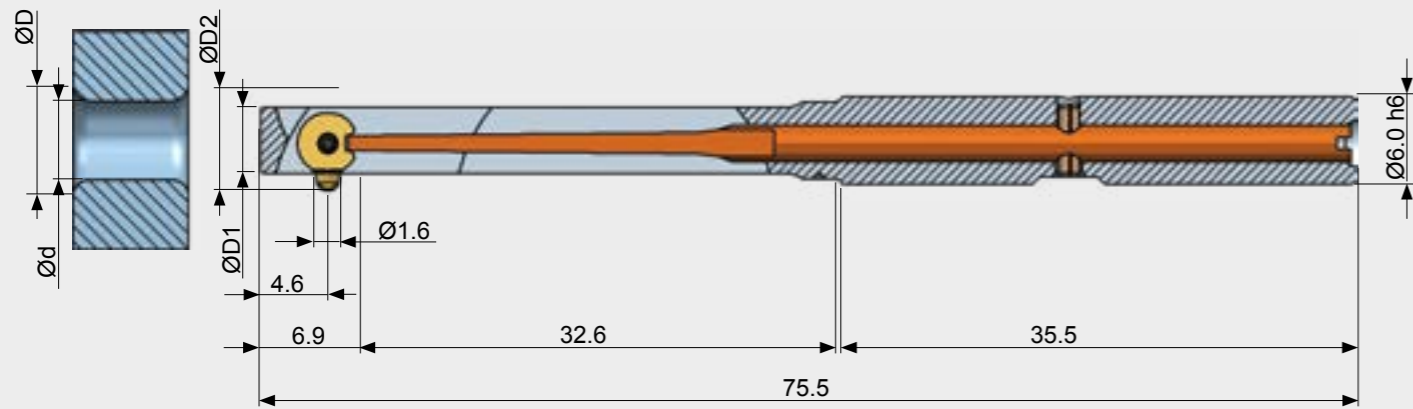

Tool Table

Bore-Ø d	Debur-Ø max. ¹ D	Tool-Ø D1	Maximum-Ø ² D2	Tool with Standard Blade	
				Part No. incl.	Spring index
5.0 - 5.1	5.7	4.9	6.6	COFA5M/5.0/ ...	Please add the spring index after the part no.! Order example: COFA 5M / 5.6 / Z1 Refer to spring index on page 33
5.1 - 5.2	5.8	5.0	6.7	COFA5M/5.1/ ...	
5.2 - 5.3	5.9	5.1	6.8	COFA5M/5.2/ ...	
5.3 - 5.4	6.0	5.2	6.9	COFA5M/5.3/ ...	
5.4 - 5.5	6.1	5.3	7.0	COFA5M/5.4/ ...	
5.5 - 5.6	6.2	5.4	7.1	COFA5M/5.5/ ...	
5.6 - 5.7	6.3	5.5	7.2	COFA5M/5.6/ ...	
5.7 - 5.8	6.4	5.6	7.3	COFA5M/5.7/ ...	
5.8 - 5.9	6.5	5.7	7.4	COFA5M/5.8/ ...	
5.9 - 6.0	6.6	5.8	7.5	COFA5M/5.9/ ...	
6.0 - 6.1	6.7	5.9	7.6	COFA5M/6.0/ ...	

¹⁾ The deburring result varies depending on material, cutting data and application. The indicated dimension is the theoretically possible maximum. The spring has to be selected accordingly.

²⁾ Pay attention to the interfering edges.

ORDERING INFORMATION

Is the tool part number written without the extension "OM" (= without blade), the standard blade GH-C-M-0505 is already mounted. Please refer to the explanations on page 25.

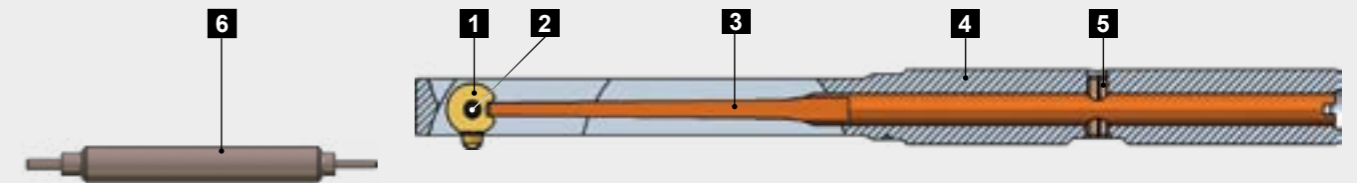

Spare Parts

Pos.	Description	Part No.
1	COFA 5M Blades	see below
2	Roll pin Ø1.2x4.8	GH-C-E-0820
3	Bending spring	see below
4	Tool body	upon request
5	Roll pin Ø1.5x5.0	GH-H-S-0902
6	Assembly pin	GH-C-V-0211

Spring Index

Type	Bending spring	Part No.	Application
W2	soft (softer than W1)	GH-C-E-0351	Special applications
W1	soft (softer than W)	GH-C-E-0350	Special applications
W	soft	GH-C-E-0352	Aluminium alloys, copper zinc alloys, soft mat.
H	hard	GH-C-E-0353*	Standard applications, all steel types
S	super hard	GH-C-E-0354	Hard and tough materials
Z	extra hard (harder > S)	GH-C-E-0355	Very tough materials or very large burr formations
Z1	extra hard (harder > Z)	GH-C-E-0356	Special applications
Z2	extra hard (harder > Z1)	GH-C-E-0357	Special applications
Z3	extra hard (harder > Z2)	GH-C-E-0358	Special applications

Blades

Angle	Part No. forward and backward cutting		Part No. backward cutting only	
	Coating T	Coating D	Coating T	Coating D
10°	GH-C-M-0705	GH-C-M-0785	GH-C-M-0815	GH-C-M-0895
20°	GH-C-M-0505*	GH-C-M-0585	GH-C-M-0915	GH-C-M-0995
25°	GH-C-M-0163	---	GH-C-M-0183	---
30°	GH-C-M-0150	---	GH-C-M-0184	---

*Standard items / Please enquire about stock or delivery times for all non-standard blades.

Explanations to coatings (see page 25)

T: Coating for steel, titanium, Inconel

D: Coating for aluminium alloys only

COFA C6 Tool Ø 6.0 mm to 8.4 mm

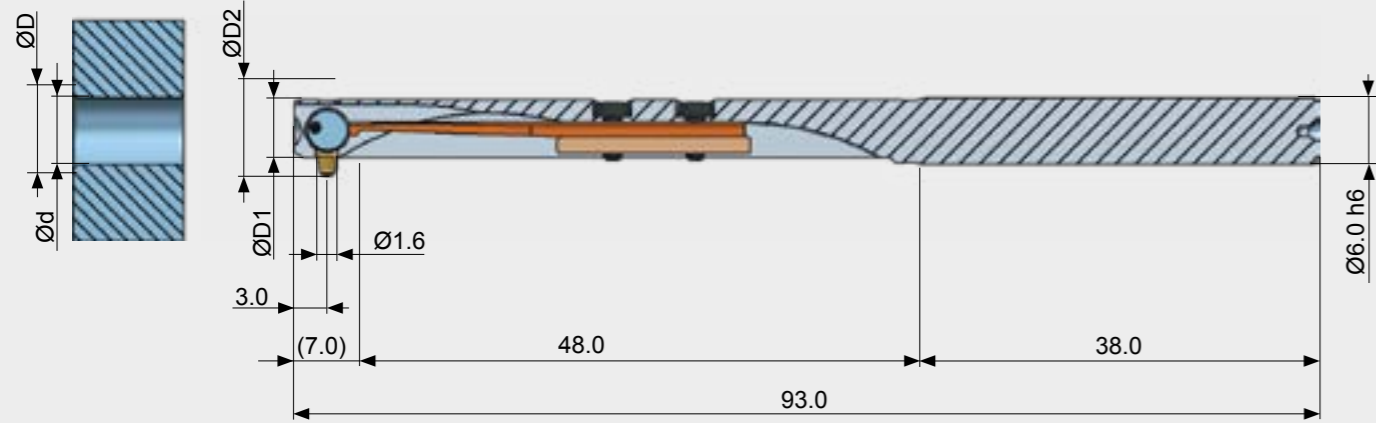

Tool Table

Bore-Ø d	Deburr-Ø¹ D	Tool with Standard Blade				Part No.	Spring index
		Tool-Ø D1		Maximum-Ø² D2			
Blade size	M	L	M	L			
6.0	7.0	7.4	5.8	8.3	8.7	C6/6.0/ ...	Please add the spring index after the part no.¹ Order example: C6/8.0/H Refer to spring index on page 35
6.2	7.2	7.6	6.0	8.5	8.9	C6/6.2/ ...	
6.4	7.4	7.8	6.2	8.7	9.1	C6/6.4/ ...	
6.6	7.6	8.0	6.4	8.9	9.3	C6/6.6/ ...	
6.8	7.8	8.2	6.6	9.1	9.5	C6/6.8/ ...	
7.0	8.0	8.4	6.8	9.3	9.7	C6/7.0/ ...	
7.2	8.2	8.6	7.0	9.5	9.9	C6/7.2/ ...	
7.4	8.4	8.8	7.2	9.7	10.1	C6/7.4/ ...	
7.6	8.6	9.0	7.4	9.9	10.3	C6/7.6/ ...	
7.8	8.8	9.2	7.6	10.1	10.5	C6/7.8/ ...	
8.0	9.0	9.4	7.8	10.3	10.7	C6/8.0/ ...	
8.2	9.2	9.6	8.0	10.5	10.9	C6/8.2/ ...	
8.4	9.4	9.8	8.2	10.7	11.1	C6/8.4/ ...	

¹) The deburring result varies depending on material, cutting data and application. The indicated dimension is the theoretically possible maximum. The spring has to be selected accordingly.

²) Pay attention to the interfering edges.

ORDERING INFORMATION

Is the tool part number without the extension "OM" (= without blade), the standard blade C6-M-0006-T is already mounted. Please refer to the explanations on page 25.

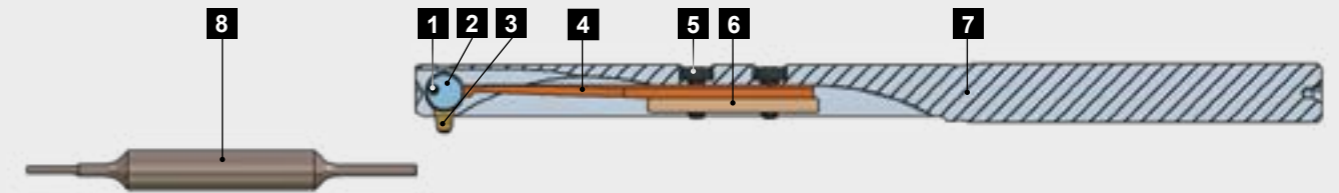

Spare Parts

Pos.	Description	Part No.
1	Roll pin Ø1.0 x 8.0	C6-E-0003
2	Blade holder	C6-E-0001
3	COFA C6 Blade	see below
4	Bending spring	see below
5	Torx screw T5 / Wrench for Pos.5	GH-H-S-0803 / GH-H-S-2006
6	Fixing strip	GH-C-E-0812
7	Tool body	upon request
8	Assembly pin	C6-V-0006

Spring Index

Type	Bending spring	Part No.	Application
W2	soft (softer than W1)	C6-E-0006	Special applications
W1	soft (softer than W)	C6-E-0007	Special applications
W	soft	C6-E-0008	Aluminium alloys, copper zinc alloys, soft mat.
H	hard	C6-E-0009*	Standard applications, all steel types
S	super hard	C6-E-0010	Hard and tough materials
Z	extra hard (harder > S)	C6-E-0011	Very tough materials or very large burr formations
Z1	extra hard (harder > Z)	C6-E-0012	Special applications
Z2	extra hard (harder > Z1)	C6-E-0013	Special applications
Z3	extra hard (harder > Z2)	C6-E-0014	Special applications

Blades

Angle	Part No. forward and backward cutting			
	Coating T		Coating D	
	M	L	M	L
10°	C6-M-0007-T	C6-M-0002-T	C6-M-0007-D	C6-M-0002-D
20°	C6-M-0006-T*	C6-M-0001-T	C6-M-0006-D	C6-M-0001-D
25°	C6-M-0008-T	C6-M-0003-T	C6-M-0008-D	C6-M-0003-D
30°	C6-M-0009-T	C6-M-0004-T	C6-M-0009-D	C6-M-0004-D

Angle	Part No. backward cutting only			
	Coating T		Coating D	
	M	L	M	L
10°	C6-M-0027-T	C6-M-0022-T	C6-M-0027-D	C6-M-0022-D
20°	C6-M-0026-T	C6-M-0021-T	C6-M-0026-D	C6-M-0021-D
25°	C6-M-0028-T	C6-M-0023-T	C6-M-0028-D	C6-M-0023-D
30°	C6-M-0029-T	C6-M-0024-T	C6-M-0029-D	C6-M-0024-D

*Standard items / Please enquire about stock or delivery times for all non-standard blades.

Explanations to coatings (see page 25)

T: Coating for steel, titanium, Inconel
D: Coating for aluminium alloys only

COFA C8 Tool Ø 8.0 mm to 12.4 mm

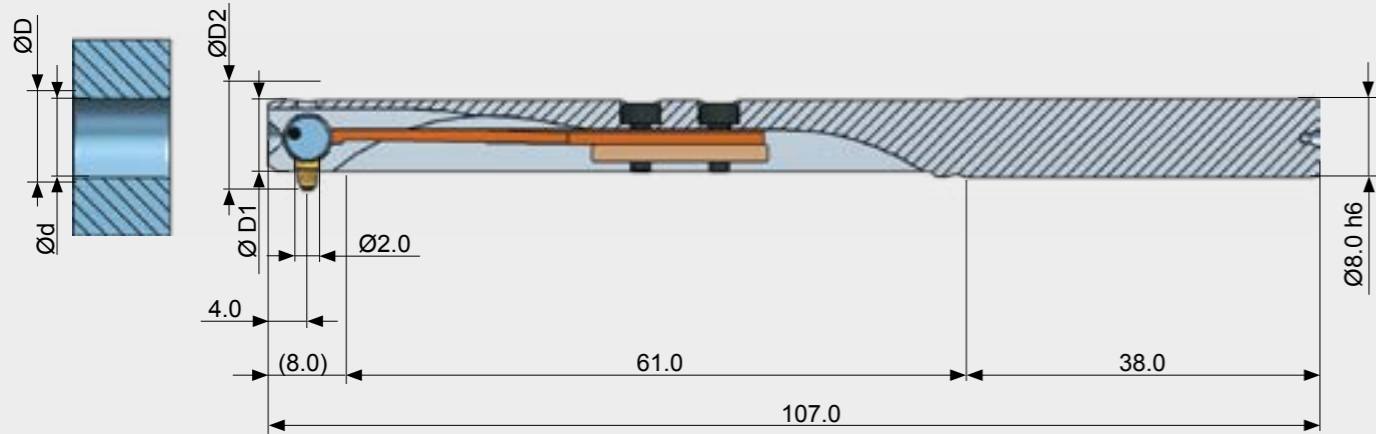

Tool Table

Bore-Ø d	Deburr-Ø¹ D	Tool with Standard Blade				Part No.	Spring index
		Tool-Ø D1		Maximum-Ø² D2			
Blade size	M	L	M	L			
8.0	9.2	9.8	7.8	10.8	11.4	C8/8.0/ ...	Please add the spring index after the part number! Order example: C8/8.0/Z1 Refer to spring index on page 37
8.2	9.4	10.0	8.0	11.0	11.6	C8/8.2/ ...	
8.4	9.6	10.2	8.2	11.2	11.8	C8/8.4/ ...	
8.6	9.8	10.4	8.4	11.4	12.0	C8/8.6/ ...	
8.8	10.0	10.6	8.6	11.6	12.2	C8/8.8/ ...	
9.0	10.2	10.8	8.8	11.8	12.4	C8/9.0/ ...	
9.2	10.4	11.0	9.0	12.0	12.6	C8/9.2/ ...	
9.4	10.6	11.2	9.2	12.2	12.8	C8/9.4/ ...	
9.6	10.8	11.4	9.4	12.4	13.0	C8/9.6/ ...	
9.8	11.0	11.6	9.6	12.6	13.2	C8/9.8/ ...	
10.0	11.2	11.8	9.8	12.8	13.4	C8/10.0/ ...	
10.2	11.4	12.0	10.0	13.0	13.6	C8/10.2/ ...	
10.4	11.6	12.2	10.2	13.2	13.8	C8/10.4/ ...	
10.6	11.8	12.4	10.4	13.4	14.0	C8/10.6/ ...	
10.8	12.0	12.6	10.6	13.6	14.2	C8/10.8/ ...	
11.0	12.2	12.8	10.8	13.8	14.4	C8/11.0/ ...	
11.2	12.4	13.0	11.0	14.0	14.6	C8/11.2/ ...	
11.4	12.6	13.2	11.2	14.2	14.8	C8/11.4/ ...	
11.6	12.8	13.4	11.4	14.4	15.0	C8/11.6/ ...	
11.8	13.0	13.6	11.6	14.6	15.2	C8/11.8/ ...	
12.0	13.2	13.8	11.8	14.8	15.4	C8/12.0/ ...	
12.2	13.4	14.0	12.0	15.0	15.6	C8/12.2/ ...	
12.4	13.6	14.2	12.2	15.2	15.8	C8/12.4/ ...	

¹) The deburring result varies depending on material, cutting data and application. The indicated dimension is the theoretically possible maximum.
The spring has to be selected accordingly. ²) Pay attention to the interfering edges.

ORDERING INFORMATION:

Is the tool part number written without the extension "OM" (= without blade), the standard blade C8-M-0006-T is already mounted. Please refer to the explanations on page 25.

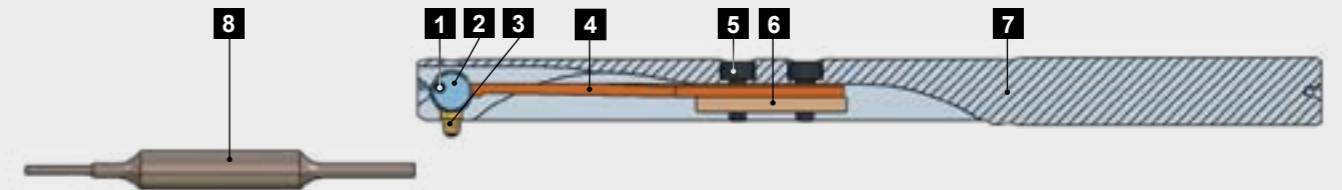

Spare Parts

Pos.	Description	Part No.
1	Roll pin Ø1.2 x 10.0	C8-E-0003
2	Blade holder	C8-E-0001
3	COFA C8 Blade	see below
4	Bending spring	see below
5	Screw M2x5.0 / Wrench for Pos.5	GH-H-S-0517 / GH-H-S-2105
6	Fixing strip	GH-C-E-0808
7	Tool body	upon request
8	Assembly pin	C8-V-0005

Spring Index

Type	Bending spring	Part No.	Application
W2	soft (softer than W1)	C8-E-0006	Special applications
W1	soft (softer than W)	C8-E-0007	Special applications
W	soft	C8-E-0008	Aluminium alloys, copper zinc alloys, soft mat.
H	hard	C8-E-0009*	Standard applications, all steel types
S	super hard	C8-E-0010	Hard and tough materials
Z	extra hard (harder > S)	C8-E-0011	Very tough materials or very large burr formations
Z1	extra hard (harder > Z)	C8-E-0012	Special applications
Z2	extra hard (harder > Z1)	C8-E-0013	Special applications
Z3	extra hard (harder > Z2)	C8-E-0014	Special applications

Blades

Angle	Part No. forward and backward cutting			
	Coating T		Coating D	
	M	L	M	L
10°	C8-M-0007-T	C8-M-0002-T	C8-M-0007-D	C8-M-0002-D
20°	C8-M-0006-T*	C8-M-0001-T	C8-M-0006-D	C8-M-0001-D
25°	C8-M-0008-T	C8-M-0003-T	C8-M-0008-D	C8-M-0003-D
30°	C8-M-0009-T	C8-M-0004-T	C8-M-0009-D	C8-M-0004-D

Angle	Part No. backward cutting only			
	Coating T		Coating D	
	M	L	M	L
10°	C8-M-0027-T	C8-M-0022-T	C8-M-0027-D	C8-M-0022-D
20°	C8-M-0026-T	C8-M-0021-T	C8-M-0026-D	C8-M-0021-D
25°	C8-M-0028-T	C8-M-0023-T	C8-M-0028-D	C8-M-0023-D
30°	C8-M-0029-T	C8-M-0024-T	C8-M-0029-D	C8-M-0024-D

*Standard items / Please enquire about stock or delivery times for all non-standard blades.

Explanations to coatings (see page 25)

T: Coating for steel, titanium, Inconel
D: Coating for aluminium alloys only

COFA C12 Tool Ø 12.0 mm to 26.0 mm

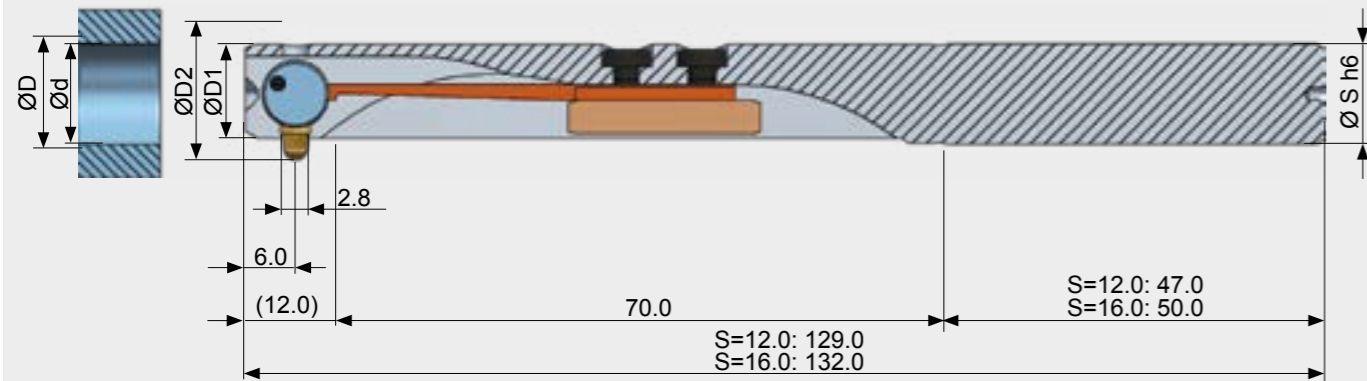

Tool Table

						Tool with Standard Blade			
Bore-Ø d	Debur-Ø¹ max. D		Tool-Ø D1	Maximum-Ø² D2		Shaft-Ø S	Part No.	Spring index	
Blade size	M	L	M	L					
12.0	13.6	14.8	11.8	15.7	17.0	12.0	C12/12.0/ ...		
12.5	14.1	15.3	12.3	16.2	17.5	12.0	C12/12.5/ ...		
13.0	14.6	15.8	12.8	16.7	18.0	12.0	C12/13.0/ ...		
13.5	15.1	16.3	13.3	17.2	18.5	12.0	C12/13.5/ ...		
14.0	15.6	16.8	13.8	17.7	19.0	12.0	C12/14.0/ ...		
14.5	16.1	17.3	14.3	18.2	19.5	12.0	C12/14.5/ ...		
15.0	16.6	17.8	14.8	18.7	20.0	12.0	C12/15.0/ ...		
15.5	17.1	18.3	15.3	19.2	20.5	12.0	C12/15.5/ ...		
16.0	17.6	18.8	15.8	19.7	21.0	12.0	C12/16.0/ ...		
16.5	18.1	19.3	16.3	20.2	21.5	12.0	C12/16.5/ ...		
17.0	18.6	19.8	16.8	20.7	22.0	12.0	C12/17.0/ ...		
17.5	19.1	20.3	17.3	21.2	22.5	12.0	C12/17.5/ ...		
18.0	19.6	20.8	17.8	21.7	23.0	12.0	C12/18.0/ ...		
18.5	20.1	21.3	18.3	22.2	23.5	12.0	C12/18.5/ ...		
19.0	20.6	21.8	18.8	22.7	24.0	12.0	C12/19.0/ ...		
19.5	21.1	22.3	19.3	23.2	24.5	12.0	C12/19.5/ ...		
20.0	21.6	22.8	19.8	23.7	25.0	16.0	C12/20.0/ ...		
20.5	22.1	23.3	20.3	24.2	25.5	16.0	C12/20.5/ ...		
21.0	22.6	23.8	20.8	24.7	26.0	16.0	C12/21.0/ ...		
26.0	Please refer to page 40								

Please add the spring index after the part number!
Order example: C12/16.0/Z
Refer to spring index on page 39

¹⁾ The deburring result varies depending on material, cutting data and application. The indicated dimension is the theoretically possible maximum. The spring has to be selected accordingly. ²⁾ Pay attention to the interfering edges.

ORDERING INFORMATION:

Is the tool part number written without the extension "OM" (= without blade), the standard blade C12-M-0006-T is already mounted. Please refer to the explanations on page 25.

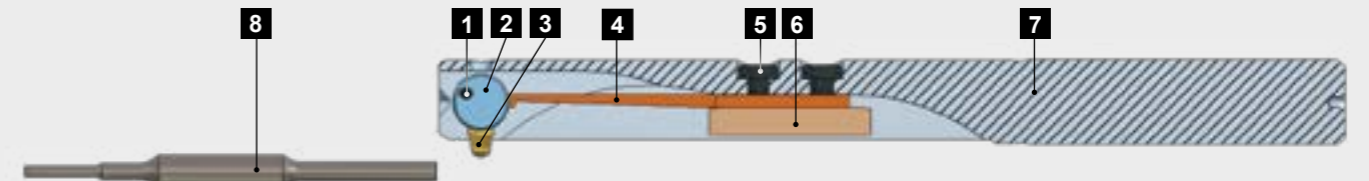

Spare Parts

Pos.	Description	Part No.
1	Roll pin Ø1.8 x 15.0	C12-E-0003
2	Blade holder	C12-E-0001
3	COFA C12 Blade	see below
4	Bending spring	see below
5	Screw M3x8.0 / Wrench for Pos.5	GH-H-S-0530 / GH-H-S-2102
6	Fixing strip	GH-C-E-0800
7	Tool body	upon request
8	Assembly pin	C12-V-0005

Spring Index

Type	Bending spring	Part No.	Application
W2	soft (softer than W1)	C12-E-0006	Special applications
W1	soft (softer than W)	C12-E-0007	Special applications
W	soft	C12-E-0008	Aluminium alloys, copper zinc alloys, soft mat.
H	hard	C12-E-0009*	Standard applications, all steel types
S	super hard	C12-E-0010	Hard and tough materials
Z	extra hard (harder > S)	C12-E-0011	Very tough materials or very large burr formations
Z1	extra hard (harder > Z)	C12-E-0012	Special applications
Z2	extra hard (harder > Z1)	C12-E-0013	Special applications
Z3	extra hard (harder > Z2)	C12-E-0014	Special applications

Blades

Angle	Part No. forward and backward cutting			
	Coating T		Coating D	
	M	L	M	L
10°	C12-M-0007-T	C12-M-0002-T	C12-M-0007-D	C12-M-0002-D
20°	C12-M-0006-T*	C12-M-0001-T	C12-M-0006-D	C12-M-0001-D
25°	C12-M-0008-T	C12-M-0003-T	C12-M-0008-D	C12-M-0003-D
30°	C12-M-0009-T	C12-M-0004-T	C12-M-0009-D	C12-M-0004-D

Angle	Part No. backward cutting only			
	Coating T		Coating D	
	M	L	M	L
10°	C12-M-0027-T	C12-M-0022-T	C12-M-0027-D	C12-M-0022-D
20°	C12-M-0026-T	C12-M-0021-T	C12-M-0026-D	C12-M-0021-D
25°	C12-M-0028-T	C12-M-0023-T	C12-M-0028-D	C12-M-0023-D
30°	C12-M-0029-T	C12-M-0024-T	C12-M-0029-D	C12-M-0024-D

*Standard items / Please enquire about stock or delivery times for all non-standard blades.

Explanations to coatings (see page 25):

T: Coating for steel, titanium, Inconel
D: Coating for aluminium alloys only

Bore-Ø d	Deburr-Ø ¹ max. D		Tool-Ø D1	Maximum-Ø ² D2		Shaft-Ø S	Tool with Standard Blade	
	M	L		M	L		Part No.	Spring index
21.5	23.1	24.3	21.3	25.2	26.5	16.0	C12/21.5/ ...	Please add the spring index after the part number! Order example: C12/16.0/Z Refer to spring index on page 39
22.0	23.6	24.8	21.8	25.7	27.0	16.0	C12/22.0/ ...	
22.5	24.1	25.3	22.3	26.2	27.5	16.0	C12/22.5/ ...	
23.0	24.6	25.8	22.8	26.7	28.0	16.0	C12/23.0/ ...	
23.5	25.1	26.3	23.3	27.2	28.5	16.0	C12/23.5/ ...	
24.0	25.6	26.8	23.8	27.7	29.0	16.0	C12/24.0/ ...	
24.5	26.1	27.3	24.3	28.2	29.5	16.0	C12/24.5/ ...	
25.0	26.6	27.8	24.8	28.7	30.0	16.0	C12/25.0/ ...	
25.5	27.1	28.3	25.3	29.2	30.5	16.0	C12/25.5/ ...	
26.0	27.6	28.8	25.8	29.7	31.0	16.0	C12/26.0/ ...	

¹⁾ The deburring result varies depending on material, cutting data and application. The indicated dimension is the theoretically possible maximum. The spring has to be selected accordingly. ²⁾ Pay attention to the interfering edges.

ORDERING INFORMATION

Is the tool part number written without the extension "OM" (= without blade), the standard blade C12-M-0006-T is already mounted. Please refer to the explanations on page 25.

COFA C20 Tool from Ø 20 mm

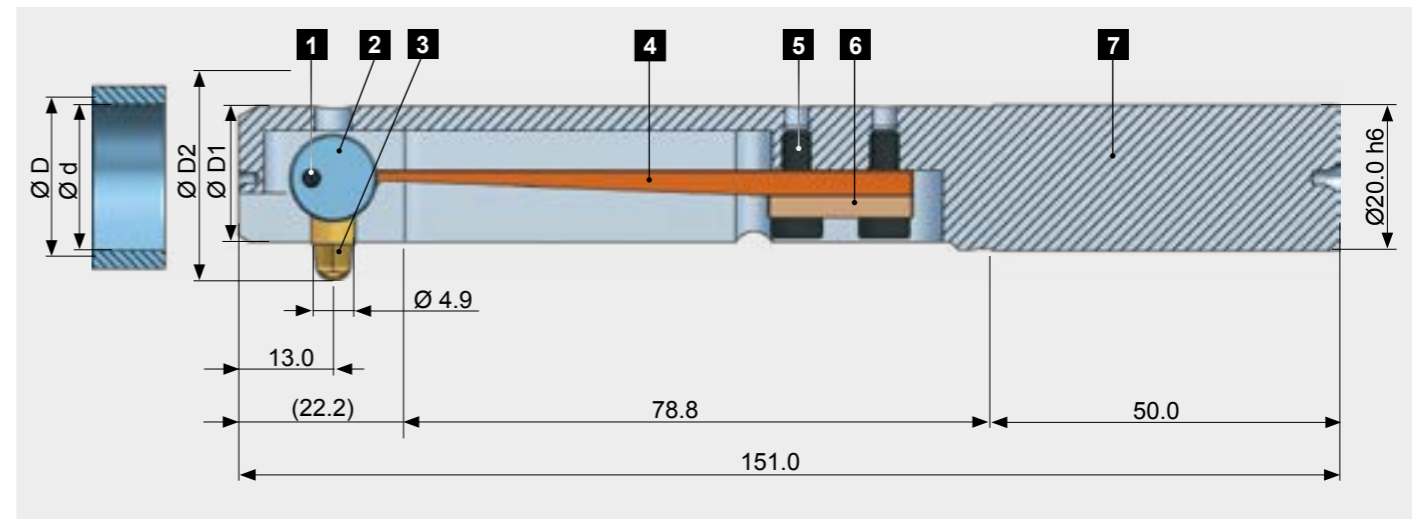

Spare Parts

Pos.	Description	Part No.
1	Roll pin Ø2.5 x 13.0	C20-E-0003
2	Blade holder	C20-E-0001
3	COFA C20 Blade	upon request
4	Bending spring	upon request
5	Screw M3x16 / Wrench for Pos.5	GH-H-S-0543 / GH-H-S-2100
6	Fixing strip	C20-E-0800
7	Tool body	upon request
	Assembly pin	C20-V-0009

The COFA C20 tool is the largest COFA tool within the HEULE product range. This deburring tool may be equipped with three different blade sizes. Depending on the specific application requirements, SMALL, LARGE or MEDIUM blades are used.

As the name says, these three blades produce deburr diameters of different size. It is important to know that these deburr diameters vary depending on the application and the material. Also COFA C20 is using springs. They differ in respect of hardness and are selected according to the material.

The C20 tool is similar to the COFA C12. The proven design of the C12 tool systems with blade holder and tool body will remain. The C20 tool is built for large to very large deburr diameters and this in connection with various materials. In order to treat a request for quotation and to carry out a feasibility study, HEULE needs the data listed below:

Information / data required by HEULE to examine the feasibility of your application¹⁾.

- Main bore-Ø including tolerance
- Cross bore-Ø including tolerance
- Bore depth
- Material
- Penetration angle
- Offset (if applicable)
- Production volume per year
- Cycle time
- Machine (CNC / others)
- Solution / process today
- Particular requirements
- STEP drawing

¹⁾ Application Data Sheet see page 254

COFA Thread Series M8 to M20

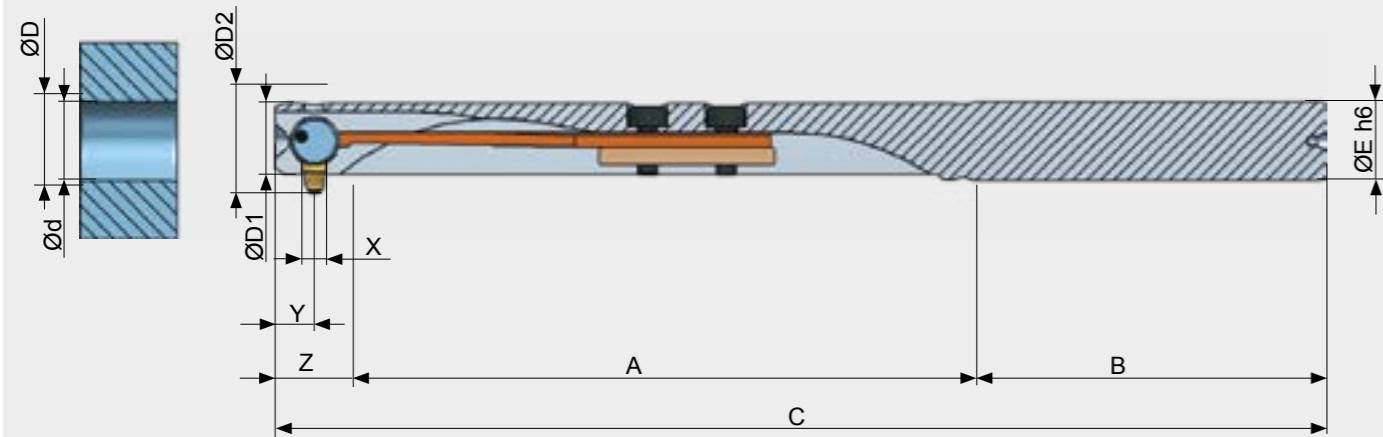

The COFA Thread Tool has been designed particularly for the deburring of threaded bores. The deburring follows the drilling of the core bore. The

dimensions of the deburring of the workpieces correspond to DIN 13-1 (ISO 68).

Tool Table

	Bore-Ø d	Debur-Ø ¹ D	Tool-Ø D1	Maximum-Ø ² D2	Tool complete with Blade	
					Part No. forward and backward cutting	Spring index
M8	6.8	8.5	6.7	9.7	C6 / M8 / ...	Please add spring index to part number! Order example: C8 / M12 / Z1 Refer to spring index on C6: 34, C8: 36, C12: 38
M10	8.5	10.4	8.4	12.2	C8 / M10 / ...	
M12	10.2	12.2	10.1	13.9	C8 / M12 / ...	
M16	14.0	16.8	13.8	18.9	C12 / M16 / ...	
M20	17.5	20.4	17.4	22.8	C12 / M20 / ...	

¹⁾ The deburring result varies depending on material, cutting data and application. The indicated dimension is the theoretically possible maximum. The spring has to be selected accordingly. ²⁾ Pay attention to the interfering edges.

ORDERING INFORMATION

Is the tool part number written without the extension "OM" (= without blade), the standard blade is already mounted. Please refer to the explanations on page 25.

Dimension Table

Type	A	B	C	X	Y	Z	ØE
M8	48.2	38.0	93.0	1.6	3.0	6.8	6.0 h6
M10	61.0	38.0	107.5	2.0	4.0	8.5	8.0 h6
M12	61.0	38.0	107.5	2.0	4.0	8.5	8.0 h6
M16	69.2	47.0	128.7	2.8	6.0	12.5	12.0 h6
M20	69.2	47.0	128.7	2.8	6.0	12.5	12.0 h6

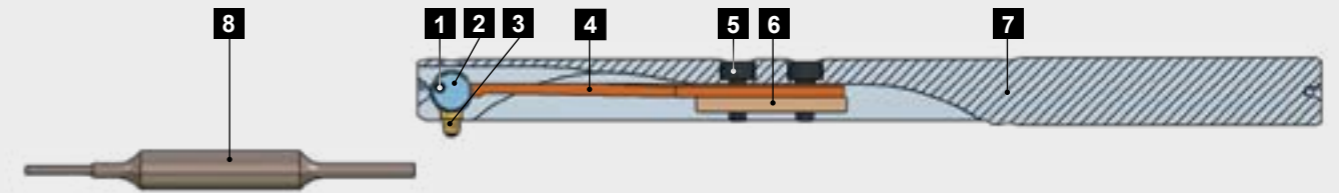

Spare Parts

Pos.	Description	M8 Ø6.7	M10/M12 Ø8.4/10.1	M16/M20 Ø13.9/17.3
1	Roll pin	C6-E-0003	C8-E-0003	C12-E-0003
2	Blade holder	C6-E-0001	C8-E-0001	C12-E-0001
3	COFA blade	see below	see below	see below
4	Bending spring	see page 35	see page 37	see page 39
5	Screw Wrench for Pos. 5	GH-H-S-0803 GH-H-S-2006	GH-H-S-0517 GH-H-S-2105	GH-H-S-0530 GH-H-S-2102
6	Fixing strip	GH-C-E-0812	GH-C-E-0808	GH-C-E-0800
7	Tool body	C6-G-0030	Ø8.4: C8-G-0030 Ø10.1: C8-G-0031	Ø13.9: C12-G-0031 Ø17.3: C12-G-0032
8	Assembly pin	C6-V-0006	C8-V-0005	C12-V-0005

Spring Index

Type	Bending spring	Part No.	Application
W2	soft (softer than W1)	The part numbers for the springs are identical with those for the standard tools. See for C6 - page 35, C8 - page 37, C12 - page 39	Special applications
W1	soft (softer than W)		Special applications
W	soft		Aluminium alloys, copper zinc alloys, soft mat.
H	hard		Standard applications, all steel types
S	super hard		Hard and tough materials
Z	extra hard (harder > S)		Very tough materials or very large burr formations
Z1	extra hard (harder > Z)		Special applications
Z2	extra hard (harder > Z1)	Special applications	
Z3	extra hard (harder > Z2)	Special applications	

Blades

	Part No. for 20° Thread Blades forward and backward cutting		Part No. for 20° Thread Blades backward cutting only	
	Coating T	Coating D	Coating T	Coating D
M8	C6-M-0001-T*	C6-M-0001-D	C6-M-0021-T	C6-M-0021-D
M10	C8-M-0001-T*	C8-M-0001-D	C8-M-0021-T	C8-M-0021-D
M12	C8-M-0001-T*	C8-M-0001-D	C8-M-0021-T	C8-M-0021-D
M16	C12-M-0001-T*	C12-M-0001-D	C12-M-0021-T	C12-M-0021-D
M20	C12-M-0001-T*	C12-M-0001-D	C12-M-0021-T	C12-M-0021-D

*Standard items / Please enquire about stock or delivery times for all non-standard blades.

Explanations to coatings (see page 25):

T: Coating for steel, titanium, Inconel
D: Coating for aluminium alloys only

COFA Cassette Systems C6 to C12

COFA C6 Cassette

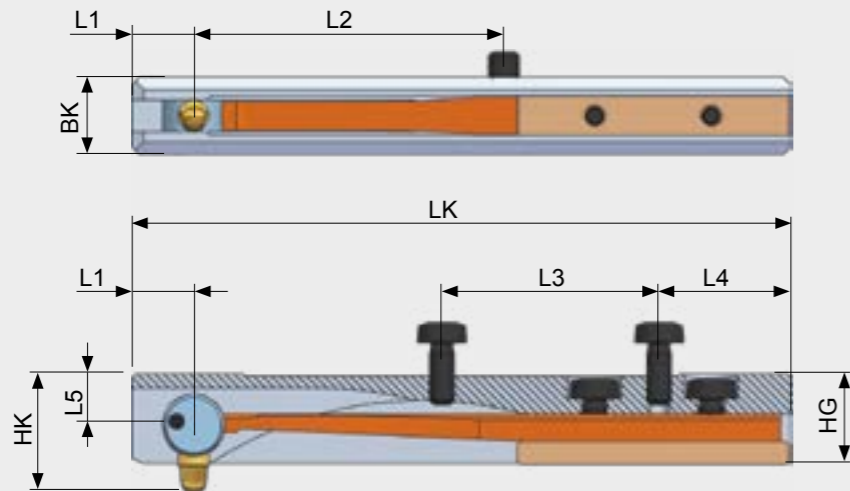

COFA C8/C12 Cassette

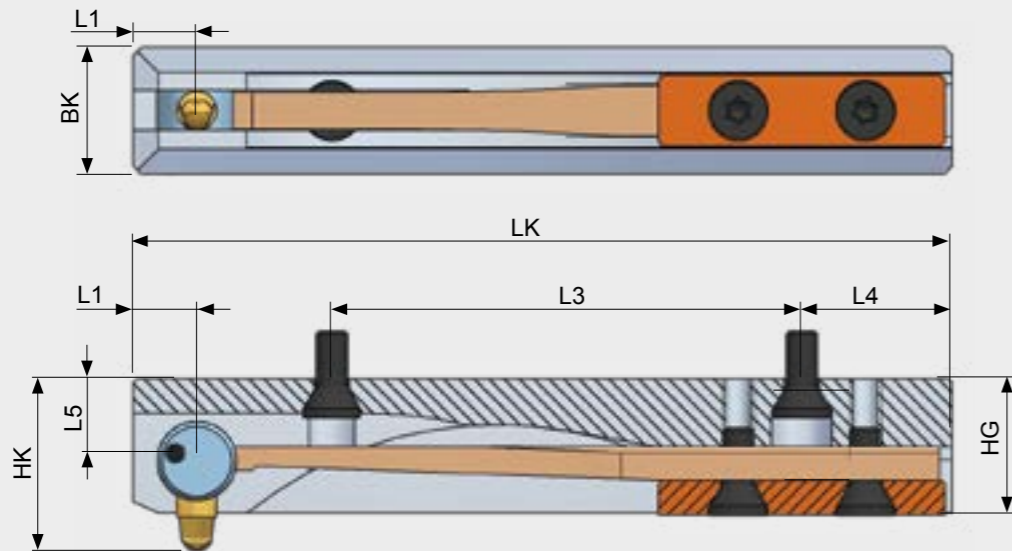

The COFA Cassette is used for installation into combination tools and cassette holders. The holder can be ordered from HEULE, or

the customers can use their own, utilising the following specifications.

Tool Table

				Cassette without Blade ¹	
Type	For bores >Ø d	Deburr-Ø D	Blade types C6 - C12	Part No.	Spring index
C6	10.0	to be calculated	see page 35	C6-O-0900/ ...	see text
C8	14.0	to be calculated	see page 37	C8-O-0900/ ...	Spring index on page 42
C12	20.0	to be calculated	see page 39	C12-O-0900/ ...	Thread Tools

ORDERING INFORMATION

¹⁾ The COFA cassettes will be supplied **without blades**. The blades have to be ordered separately always. Please refer to pages 35, 37, 39.

COFA C6

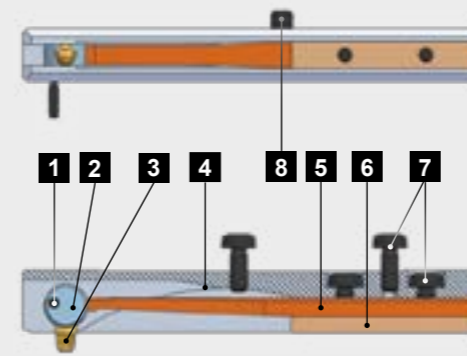

COFA C8 / C12

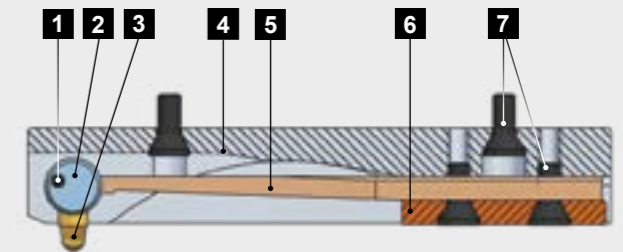

Spare Parts

Pos.	Description	C6	C8	C12
1	Roll pin	C6-E-0003	C8-E-0003	C12-E-0003
2	Blade holder	C6-E-0001	C8-E-0001	C12-E-0001
3	COFA blade	see page 35	see page 37	see page 39
4	Tool body	C6-G-0900	C8-G-0900	C12-G-0900
5	Bending spring	see below	see below	see below
6	Fixing strip	GH-C-E-0812	C8-E-0800	C12-E-0800
7	Screw	GH-H-S-0803	GH-H-S-0050	GH-H-S-0012
8	Threaded pin M2x2	GH-H-S-0137	-	-

Spring Index

Type	Bending spring	Part No.	Application
W2	soft (softer than W1)	The part numbers for the springs are identical with those for the standard tools. See for C6 - page 35 C8 - page 37 C12 - page 39	Special applications
W1	soft (softer than W)		Special applications
W	soft		Aluminium alloys, copper zinc alloys, soft mat.
H	hard		Standard applications, all steel types
S	super hard		Hard and tough materials
Z	extra hard (harder > S)		Very tough materials or very large burr formations
Z1	extra hard (harder > Z)		Special applications
Z2	extra hard (harder > Z1)		Special applications
Z3	extra hard (harder > Z2)		Special applications

Dimension Table

Typ	BK	HG	LK	HK	L1	L2	L3	L4	L5
C6	5.0	5.8	42.5	see page 47	4.0	20.0	14.0	8.5	3.3
C8	8.0	8.5	51.5		4.0	-	29.6	9.5	5.2
C12	10.0	13.0	60.0		7.5	-	35.0	8.5	7.7

COFA C6
Ø10.0-14.99 mm

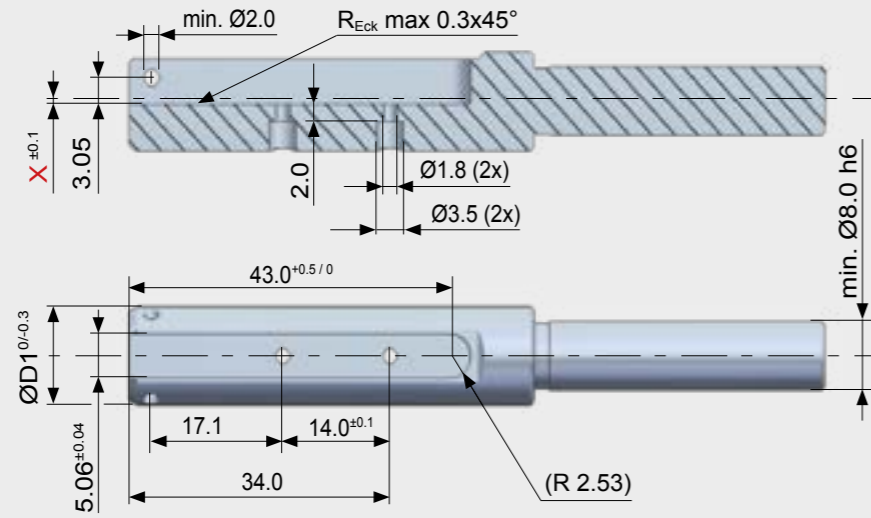

COFA C6
>15.0 mm

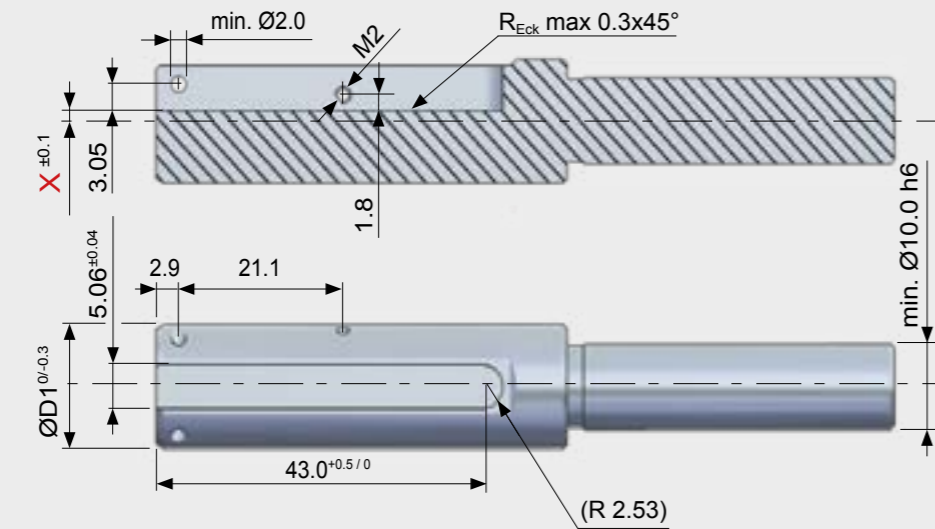

COFA C8
COFA C12

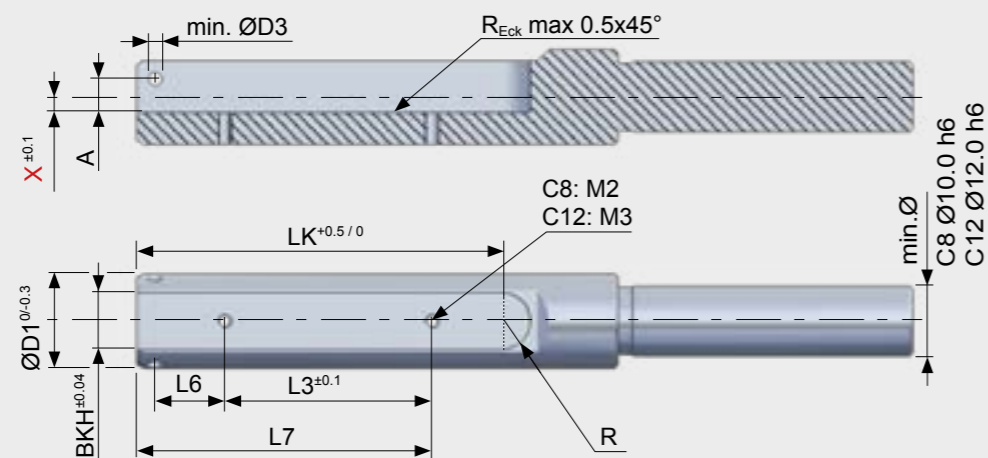

Limiting Values

from Bore Ø	C6		C8		C12	
	M	L	M	L	M	L
Ø10.0			Ø14.0		Ø20.0	
max. ØD	Ød + 0.8	Ød + 1.4	Ød + 1.1	Ød + 1.8	Ød + 1.5	Ød + 2.8
max. ØD1	Ød - 0.5		Ød - 0.5		Ød - 0.5	

Dimension Table Cassette Holder

	BKH	LK	D3	L3	L6	L7	X	A	R
C6	see p. 46	see p.46	see p.46	see p.46	see p.46	s. p. 46	Must be calculated for every application (see formula below)	see p.46	s. p. 46
C8	8.06	52.0	2.0	29.6	9.85	42.1		4.70	4.03
C12	10.06	61.0	3.0	35.0	11.1	51.5		6.45	5.03

C6: $X = \text{Ød}/2 - 6.3$

C8: $X = \text{Ød}/2 - 9.2$

C12: $X = \text{Ød}/2 - 13.7$

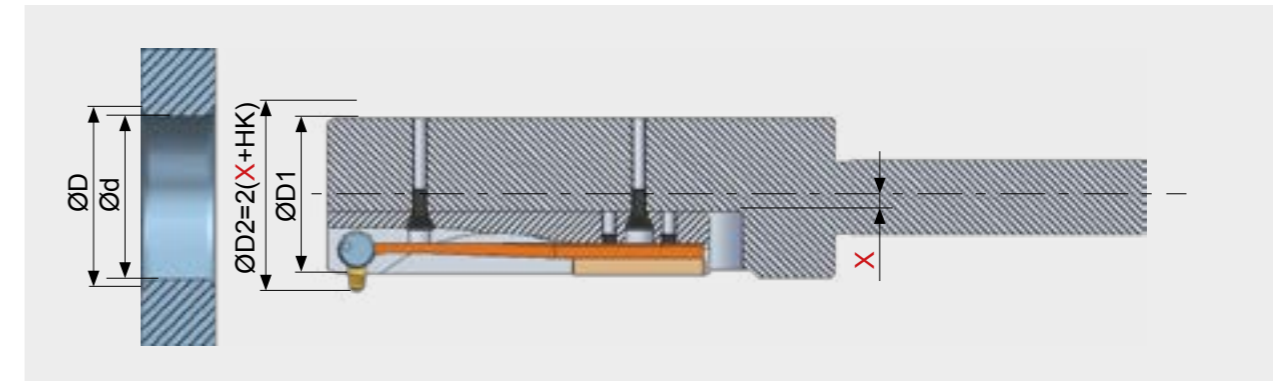

HK C6		HK C8		HK C12	
M	L	M	L	M	L
7.6	7.8	10.6	11.0	15.6	16.2

Technical Data and Settings

Cutting Data COFA

Material	Condition	Tensile strength (N/mm ²)	Hardness HB	COFA C2 / C3		COFA 4M to C12	
				Cutting speed (m/min)	Feed (mm/rev)	Cutting speed (m/min)	Feed (mm/rev)
Unalloyed steel		<500	<150	20-60	0.05-0.15	20-60	0.1-0.3
Cast steel		500 - 850	150 - 250	20-60	0.05-0.15	20-60	0.1-0.3
Grey cast iron		<500	<150	30-80	0.05-0.15	30-80	0.1-0.3
Ductile cast iron		300 - 800	90 - 240	20-60	0.05-0.15	20-60	0.1-0.3
Low alloy steel	annealed	<850	<250	20-60	0.05-0.15	20-60	0.1-0.3
	tempered	850 - 1000	250 - 300	20-40	0.05-0.15	20-40	0.1-0.3
	tempered	>1000 - 1200	>300 - 350	15-30	0.05-0.15	15-30	0.1-0.3
High alloy steel	annealed	<850	<250	15-30	0.05-0.15	15-30	0.1-0.3
	tempered	850 - 1100	250 - 320	10-20	0.05-0.15	10-20	0.1-0.3
Stainless steel	ferritic	450 - 650	130 - 190	15-30	0.05-0.15	15-30	0.1-0.3
	austenitic	650 - 900	190 - 270	10-20	0.05-0.15	10-20	0.1-0.3
	martensitic	500 - 700	150 - 200	15-30	0.05-0.15	15-30	0.1-0.3
Special alloy (Inconel, titanium)		<1200	<350	10-20	0.05-0.15	10-20	0.1-0.3
Wrought or cast aluminium alloys				30-70	0.05-0.15	30-70	0.1-0.3
Copper alloy	Brass			30-70	0.05-0.15	30-70	0.1-0.3
	Bronze short-chipping			20-60	0.05-0.15	20-60	0.1-0.3
	Bronze long-chipping			20-40	0.05-0.15	20-40	0.1-0.3

WARNING NOTICE

All listed cutting data are standard values only! The cutting values depend on the amount of slope of the uneven bore edge. (i.e. high slope ► low cutting value). The feed also depends on the sloping ratio. In case of hard to machine materials or uneven bore edges, we recommend to apply cutting speeds that are at the lower end of the range for uneven bore edges.

Programming Information COFA

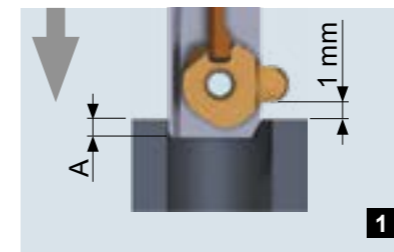

Rapid traverse of the cutting unit of the tool above the top material surface of hole or burr. Referencing the front edge of the cutting blade **A**.

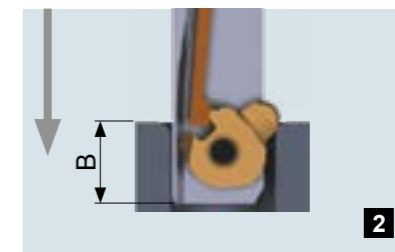

In forward working feed machine the top surface of the hole to position **B**.



Rapid traverse through the hole. The surface of the hole cannot be damaged.

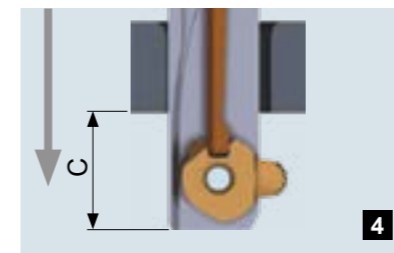

In order to make the blade snap out again, the tool has to be positioned beyond the rear bore edge by measurement **C**.

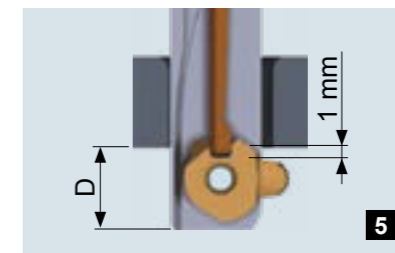

Travel the tool back in rapid feed below the rear material surface of the hole or the burr **D**.

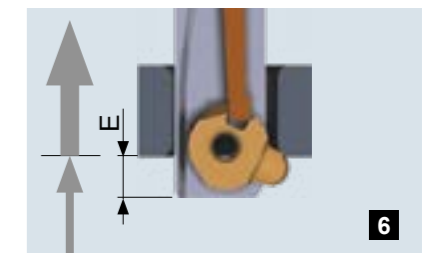

In back working feed the backward deburring is executed until position **E**. Then exit in rapid traverse.

Dimension Table to Programming Information

Tool	A	B	C	D	E
COFA C2	1.7	4.5	4.5	4.3	1.5
COFA C3	2.5	6.0	6.0	5.5	2.0
COFA 4M	2.0	5.5	5.5	5.3	1.8
COFA 5M	2.8	7.0	6.9	6.4	2.2
COFA C6 Medium	1.1	6.3	6.5	4.9	-0.3
COFA C6 Large	1.1	6.8	6.8	4.9	-0.8
COFA C8 Medium	1.9	8.0	8.1	6.1	0
COFA C8 Large	1.9	8.8	8.5	6.1	-0.4
COFA C12 Medium	3.4	11.6	11.6	8.6	0.4
COFA C12 Large	3.4	13.0	12.5	8.6	-1.0

NOTE

Important - Please pay attention to irregular surfaces! Please consider unevenness when programming the distances. See also the explanations on page 55.



Assembly device for tool type COFA C2 / C3

Please refer to page 53 for order information.

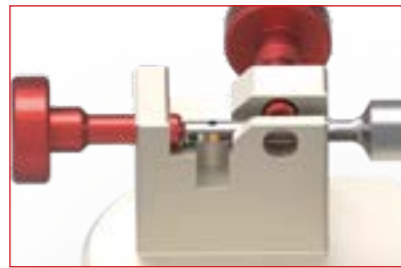

Adjust the tool lengthwise so that the blade bore is above the recess for the roll pin. Then clamp the tool. Make sure that the larger spring recess in the shaft is on clamp screw side.

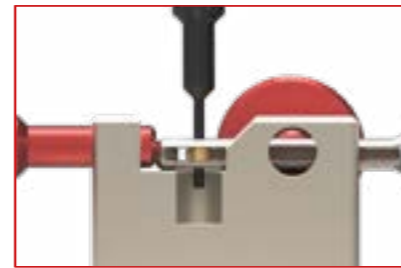

Push the roll pin out of the tool by using the smaller diameter of the assembly pin.

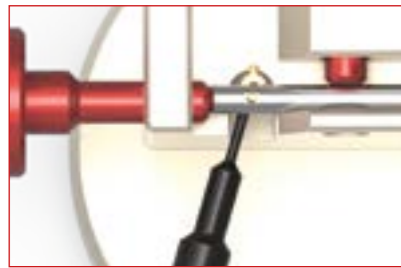

Push out the blade by using the smaller diameter of the assembly pin.

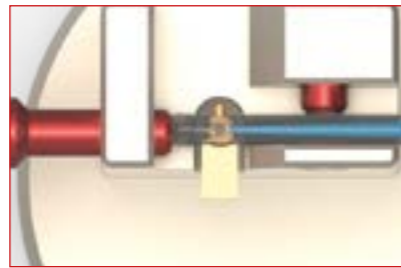

Insert the new blade nose first. The nose must be on the side of the shaft where the larger spring recess is (observe the mark on the tool). The spring must engage with the groove of the blade.

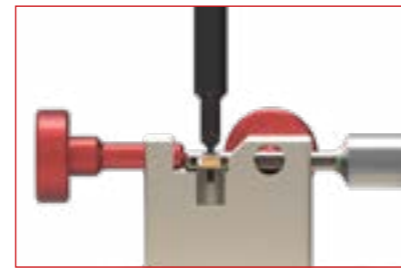

Center the blade with the help of the assembly pin. Its smaller diameter serves for pre-centering.



Insert roll pin with its longer and thinner section first.



Use assembly pin to push roll pin level with blade. Then unclamp the tool.



Brake off the assembly aid extensions of the blade and from the roll pin manually.



Assembly device for tool types COFA 4M and 5M

Please refer to page 53 for order information.

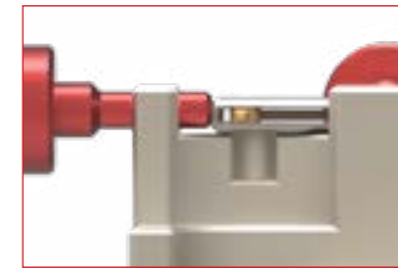

Adjust the tool lengthwise so that the blade bore is above the recess for the split pin. Clamp the tool as shown.



Push the split pin carefully out of the bore. Make sure you apply the assembly pin to the split end of the pin. If necessary, use a small hammer.

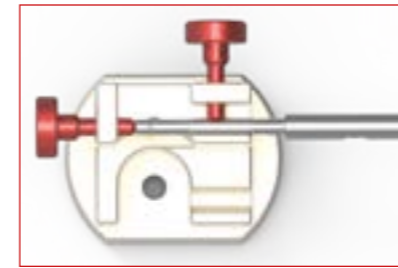

Push out the blade by means of the long end of the assembly pin.

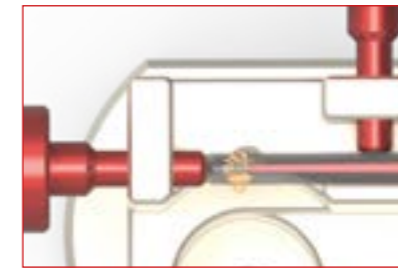

Insert the new blade into the tool with the blade groove orientated towards the spring. Please observe the marks on the tool body.

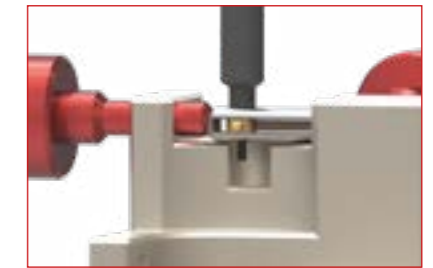

Guide the assembly pin with its long end through the bore and center the blade.



Insert the split pin manually with the split end upwards. Then push it with the assembly pin.

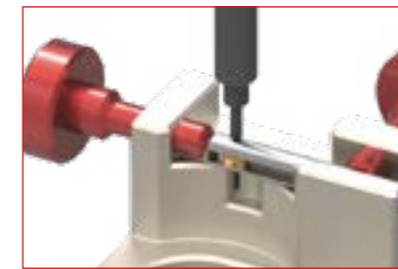

The assembly pin must be level with both sides of the tool body.



Assembly device for tool types COFA C6 - C12

Note: Execute blade change on mounted tool only.

Please refer to page 53 for order information.

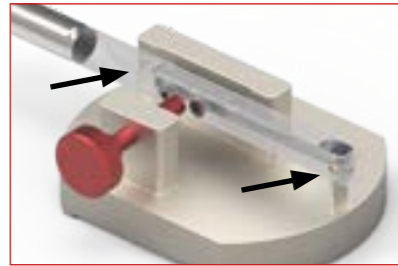

Place tool into the assembly device so that support pin from the assembly device enters into the spring recess behind the fixing strip and that the tool holder lies with its contour flush on the front rest.



Make sure that the bore with the split pin is entirely free. Then, clamp the tool.



There are a line mark and the black split pin visible (see remark on page 53). Push the split pin through the tool holder by using the smaller diameter of the assembly pin (same direction for disassembly and assembly!).



Use larger diameter of assembly pin to push the blade out of the blade holder.



Insert new blade with cutting edges up into the blade holder. Make sure that the blade is pushed in from the line mark side.



In order to define the right position of the blade and to pre-center for the new split pin, push the assembly pin in the split pin hole.



Insert new split pin short section first into the hole until the back end of the pin is flush with tool holder.



Loosen clamping screw and take the tool into your hands. Manually brake off the projecting section of the split pin at the predetermined breaking point.



The positioning pin (A) is a fixed component of the tool holder. The positioning pin and the black split pin are responsible for the correct position of the blade.



Only the split pin (B) may be removed for dismantling the blade. The positioning pin must remain in the blade holder.

NOTE

When changing the blade the positioning pin **must not** be removed. Please observe that re-inserting it after removal is prohibited. The correct positioning of the blade after inserting **cannot** be guaranteed anymore.

Accessories – Assembly Aid for Blade Change

Assembly Aid	
Type	Part No.
COFA C2 and C3	C3-V-0002



Assembly Aid	
Type	Part No.
COFA 4M and 5M	GH-C-V-0541



Assembly Aid	
Type	Part No.
COFA C6	C6-V-0008
COFA C8	C8-V-0007
COFA C12	C12-V-0018



Maximum Slope

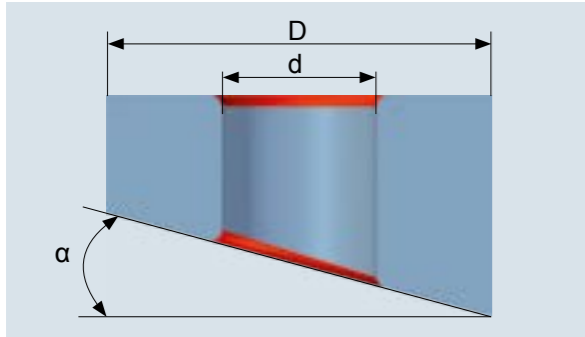

The maximum diameter ratio (d:D) is about 0.5. This corresponds approximately to a sloping surface of $\leq 18^\circ$.

For diameter ratios (d:D) exceeding 0.5, respectively inclined surfaces with α larger than 18° , only a trial will show whether the application can be resolved successfully with the COFA standard blade (20°). The machining of higher irregularities can be done upon request with special blades (see blade range in respective blade table 10° , 25° , 30°).

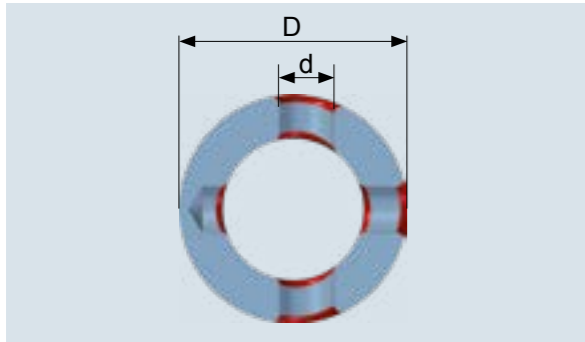

Formula for verifying the possible use of standard blades:

$$d:D \leq 0.5$$

Cutting data for uneven bore edges:

- ▶ Speed: reduce
- ▶ Feed: leave

Prevention of Blade Breakage due to high Unevenness

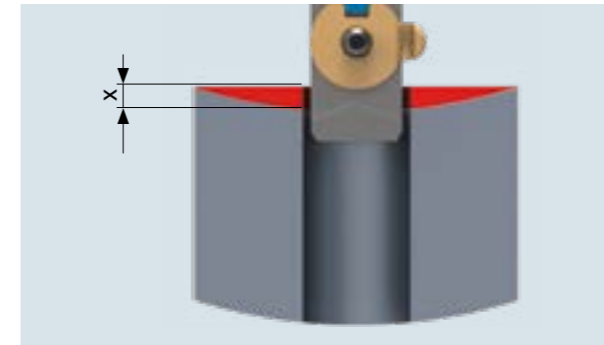

Please pay attention to irregular surfaces! Please consider unevenness X when programming the distances.



When machining bores with a high unevenness, it is important to stop the spindle before retracting the tool out of the bore. This will prevent the blade from hitting hard the slope of the exterior.

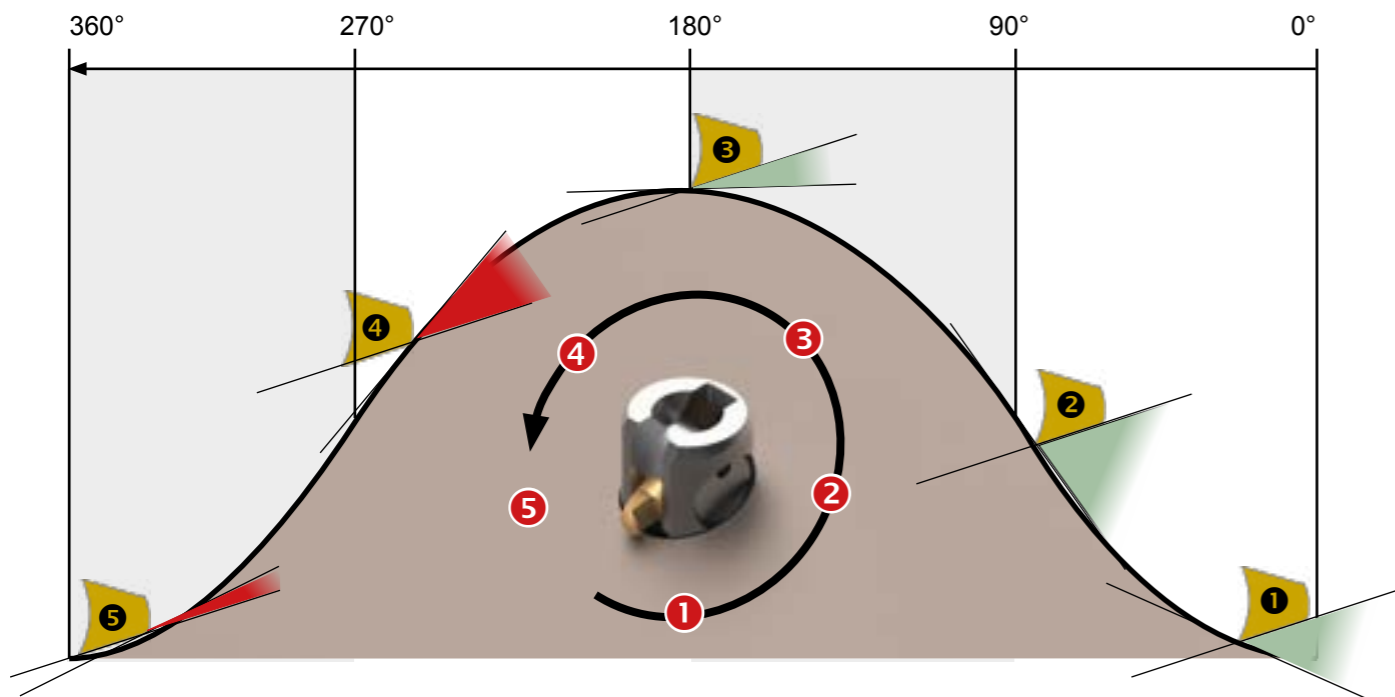

NOTE

The clearance angle of the blade must be larger than the gradient of the sinus curve (slope) in order that the blade remains cutting. If this is not the case, the blade rests on the workpiece. With the result that there is no deburring or only partially (not the full circle) because the blade lies with its back on the workpiece.

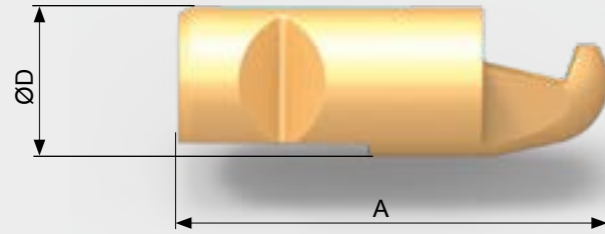

Dimension Table

	COFA C6		COFA C8		COFA C12	
	M	L	M	L	M	L
ØD	Ø2.0 h6	Ø2.0 h6	Ø2.5 h6	Ø2.5 h6	Ø3.5 h6	Ø3.5 h6
A	6.05	6.25	7.54	7.85	11.57	11.98

FAQ COFA

Problem	Reason	Remedial Action
Bad uneven chamfer	• Rpm too high	⇒ Reduce rpm strongly, keep feed rate
	• Ratio between cross hole and tube dia.Ø (d:D) is larger than 0.5	⇒ Ratio is too big for the tool, no solution possible with COFA
	• Too large tool chosen	⇒ Use a tool with smaller diameter (for example C12/Ø15.0 ► C12/Ø14.5)
Vibrations, chattering marks	• Rpm too high	⇒ Reduce rpm
	• Feed rate too low	⇒ Increase feed rate (per revolution)
	• Spring too soft	⇒ Build in harder spring (spring index), existing tool can be modified
Chamfer too large	• Too large tool chosen	⇒ Use a tool with smaller diameter (for example C12/Ø15.0 ► C12/Ø14.5) or if applicable a smaller blade size
Deburring incomplete	• Spring too soft	⇒ Build in harder spring (spring index), existing tool can be modified
	• Clearance angle too small	⇒ Use another blade
Secondary burr	• Spring too hard	⇒ Build in softer spring



SNAP
Online Information



Product Video

www.heule.com/en/chamfering-tool/snap



Case Studies

www.heule.com/en/case-studies/?t=18



Contact Sales Represen.

www.heule.com/en/contact-sales-representatives



Request for Quote Form

www.heule.com/en/request-for-quote/



Manual

www.heule.com/en/service/manual/snap



SNAP

Economic front and back chamfering in one operation, with most easy blade change.

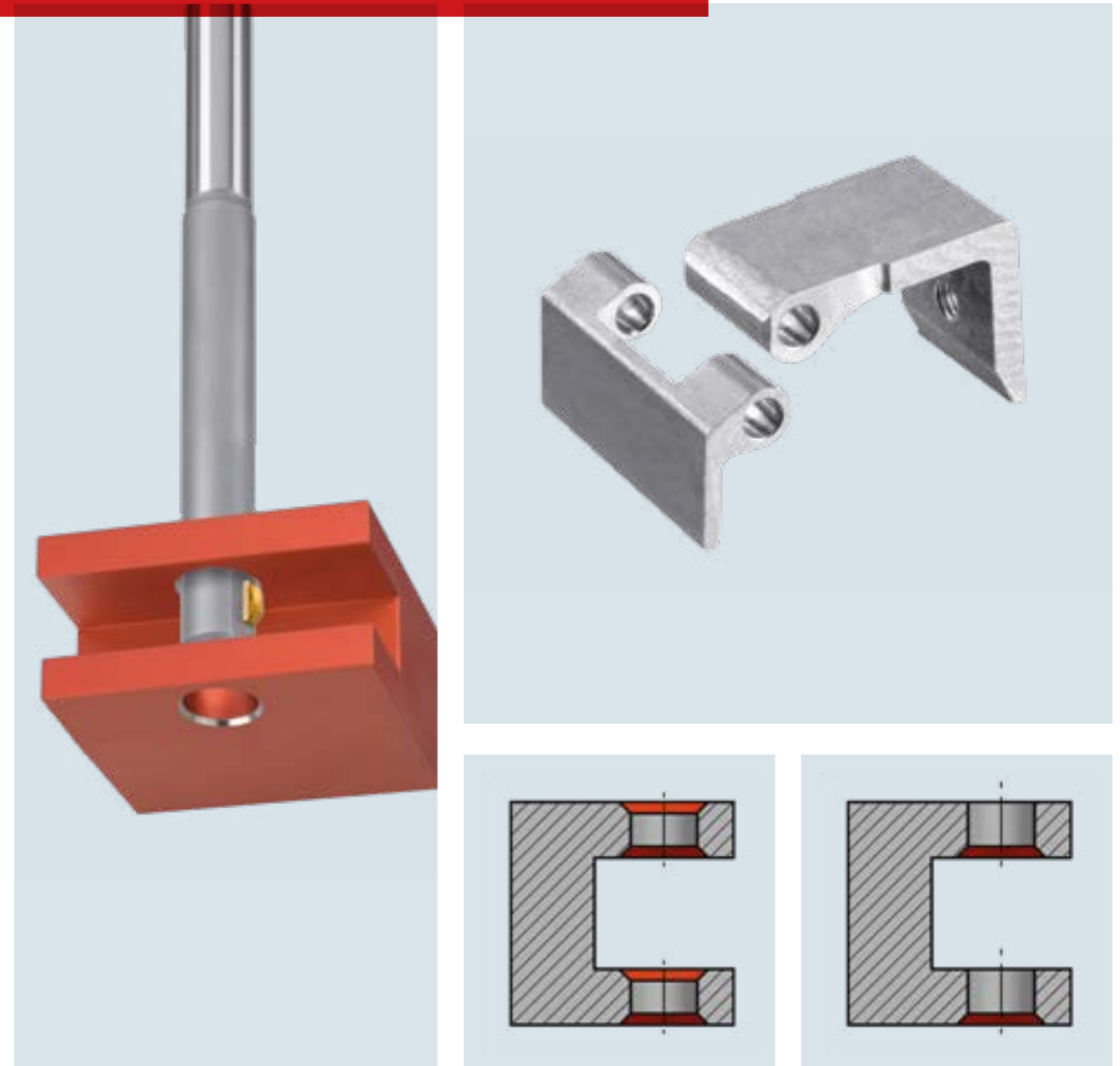



SNAP – The Economic Chamfering Tool



Economic front and back chamfering of bores in ONE OPERATION, with very easy blade change.

The SNAP tool is an efficient front and back chamfering and deburring tool that is easy to use and which allows quick blade changes, making it a convenient solution for any manufacturing environment. Without any need to turn the workpiece or to stop the spindle, the tool removes the burrs and chamfers the edges.

The SNAP tool has been designed for automatic operation involving large production lots. The tool is characterised by its most simple blade change that is carried out manually and without any specific aids.

Characteristics and Advantages

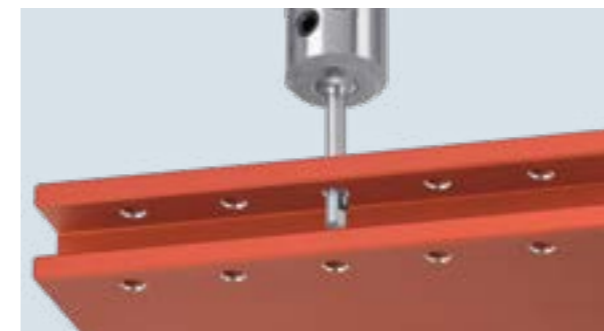

- The SNAP standard tool series ranges from bore diameter 2.0 mm to 35.0 mm. The cassette system is designed for bore diameters larger than 35.0 mm.

- As manufacturer of this tool system, HEULE is able to provide also tailor-made solutions for customer-specific applications.



- SNAP produces chamfers and countersinks ranging from 0.2 - 1.5 mm depending on bore diameter and blade.

- Different blades can be used in one tool in order to achieve different chamfer sizes. The geometry of the blade defines the chamfer size.

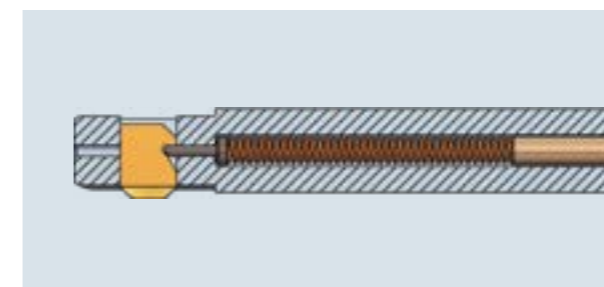

- The combination of the mechanical spring-load controlled function principle with the robust design are responsible for the outspoken reliability.

- The application of the tool is very user-friendly. It is ready to use quickly without any preadjustments.

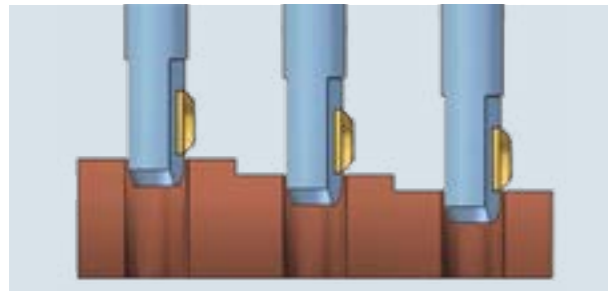

- The blade starts to cut only when it is in touch with the workpiece. This ensures a consistent chamfer capacity no matter where the machining level is. SNAP compensates possible height irregularities of the workpieces to be machined automatically, i.e. such as cast parts.

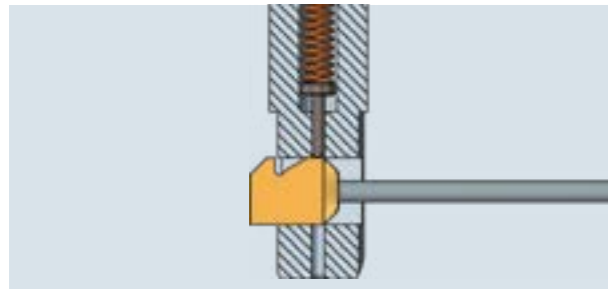

- The easy to exchange carbide blades are carried out with material dependent coatings. Any blunt object or a plastic bolt may serve for pushing out the blade.



- The simple and compact design combined with its fully mechanical function principle guarantee its reliable operation.



- The penetration of the bore does not injure the bore surface. Thanks to its especially developed sliding section, the blade slides softly with minimal friction over the bore surface.

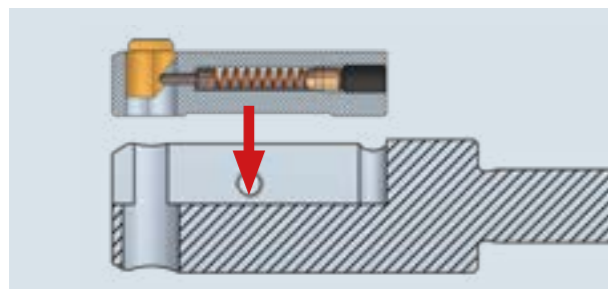

- The cassette solution (simple tool holder with cassette tool) expands the maximum diameter of still machinable bore edges without limits.
- The cassette solution allows to integrate the chamfering process into an existing customer tool. By combining two or several processes in one single tool, the cycle time of the production process can be reduced considerably.

The SNAP tooling system's simple design makes it suitable ideally for all production processes where high process stability is required. No complicated or time consuming setting is necessary to make the tool ready for operation. The drilled hole diameter determines the size of tool required and the desired

chamfer size determines the blade. For instance, if a larger chamfer size is needed, you simply exchange the existing blade by the next larger blade. For instance, with a given bore-Ø of 4.4 mm the chamfer sizes-Ø 4.8, 5.2 and 5.6 are producible with different blades (see page 72).



Tool Description

The SNAP range is HEULE's answer to the increasing demand for simpler and more flexible manufacturing solutions.

Designwise, the SNAP tool family consists of 3 types. There is SNAP2, 3 and 4 on one hand, SNAP5 to 20 on the other hand. The third group are the cassette tools.

The design concepts differ because of their sizes. Whereas the tool body of SNAP5 up to SNAP20 is a one-piece construction, it is split up into tool body and blade housing for SNAP2 upto SNAP4. The cassette tools use the identical function principle but are built in a more compact design.



Image: SNAP2 - The design of the tool body consists of two components for dimension reasons: a tool body and a blade housing.



Image: SNAP5 - The so called "B" form of the blade is more complex with regard to production. However, its improved guiding capacities justify this design for this tool size.

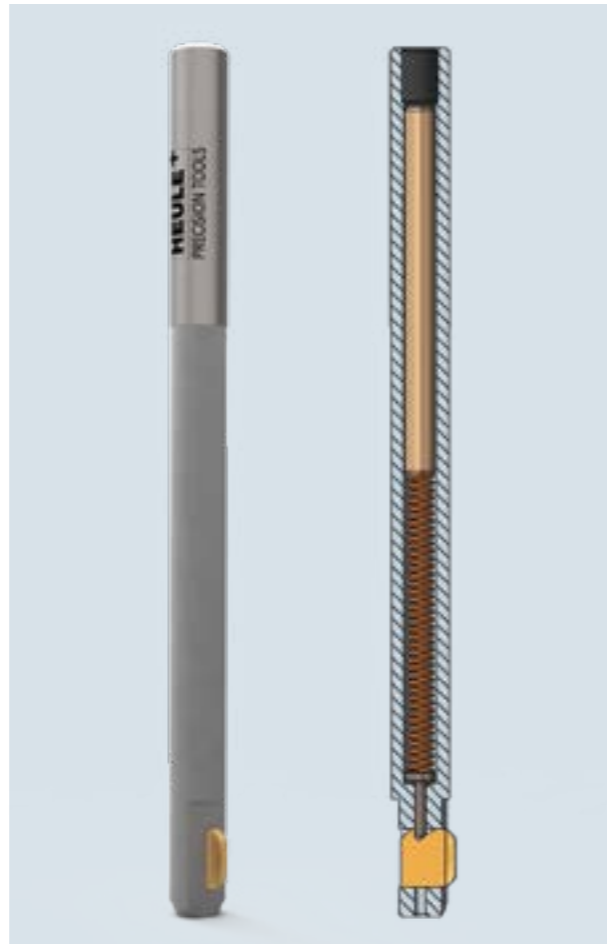
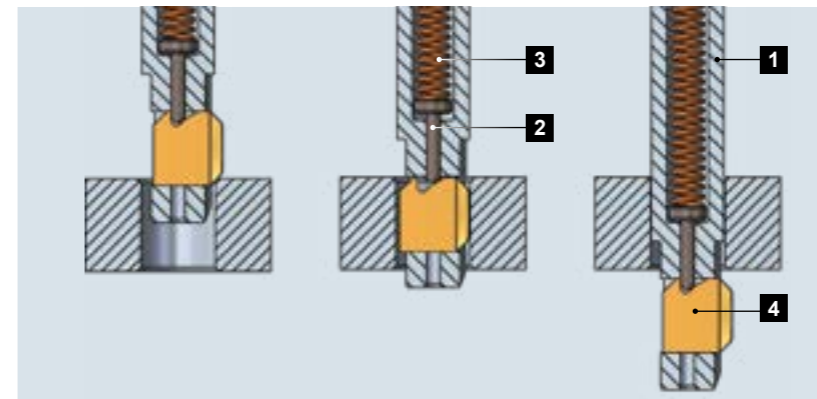

Image: SNAP8 - Unlike the smaller tool types SNAP2 up to 4 this tool has one tool body and 5 other components only.

The SNAP technology offers a very user-friendly and competitive front and back chamfering system. For instance, the blade can be exchanged easily manually without any need for additional tools. The complete SNAP tool consists of six components only.

The workpiece is machined with a rotating spindle similar to a drill. In one single pass and without changing the direction of the spindle rotation, it is possible to chamfer the front as well as the back of the bore neatly. Once the predefined chamfer size has been reached, the blade moves automatically into the tool body. So, it passes in rapid traverse through the bore. The ball shape of the blade protects the bore surface from being damaged at the contact point.

Function Principle



- 1 Tool Body
- 2 Control Bolt
- 3 Spring
- 4 SNAP Chamfer Blade

The SNAP deburring blade is kept movable in the tool body via a control bolt held under spring pressure. A specially ground forward and backward or backward cutting only blade produces the required chamfer whilst the tool enters the bore. Once the chamfer size is attained, the deburring blade continuously retracts into the tool body. On a specially designed gliding radii, the blade passes through the hole without damaging it. The deburring

blade has a special recess which the control bolt engages in and after exiting the hole brings the blade back into its starting position. A smooth deburring or chamfering operation forwards and backwards is the result of this machining operation. Chamfer size and chamfer angle are predetermined geometrically at the blade and can only be changed by the use of another blade of an adapted design.

Process Steps Description

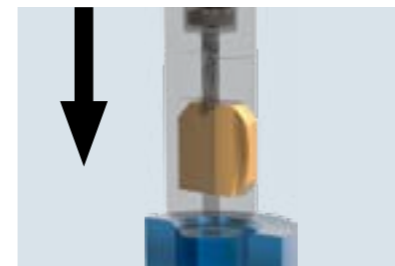

The process is very simple. First, rapid traverse of the cutting unit above the top material surface of hole or burr. Referencing the front edge of the cutting blade.

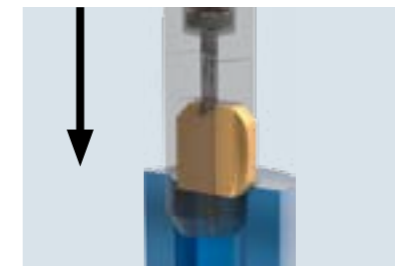

In working feed and working speed, the deburring/chamfering of the upper bore edge is carried out.



Once the chamfer size is attained, traverse in rapid feed through the hole without stopping the spindle.



Despite the swivel movement of the spindle, the blade passes through the hole without damaging it. Even reamed bores can be passed through without any damage.

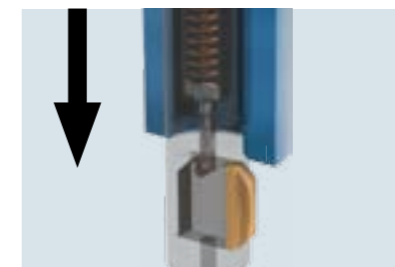

Once clear of the back side of the bore, rapid feed is stopped and the SNAP blade returns to its starting position.

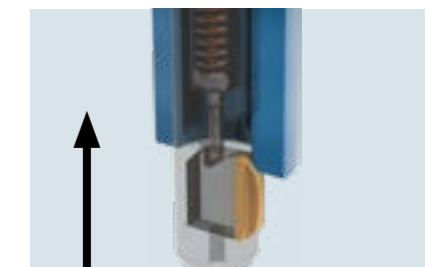

Without stopping the spindle or or change of direction of the spindle, linear feed backward then allows the machining of a suitable back chamfer. Once finished, traverse in rapid speed and without stopping the spindle out of the hole.

SNAP Range Summary

The tool range comprises of tools for the use in bore diameters ranging from 2.0 mm to 35.0 mm. In addition, using cassettes, any size of bore diameter can be chamfered. The chamfering capacity (radi-

ally) is 0.1 mm up to 1.5 mm depending on blade selection. Within one tool type series, there are variants of diameters that cover the range up to next larger tool type series.

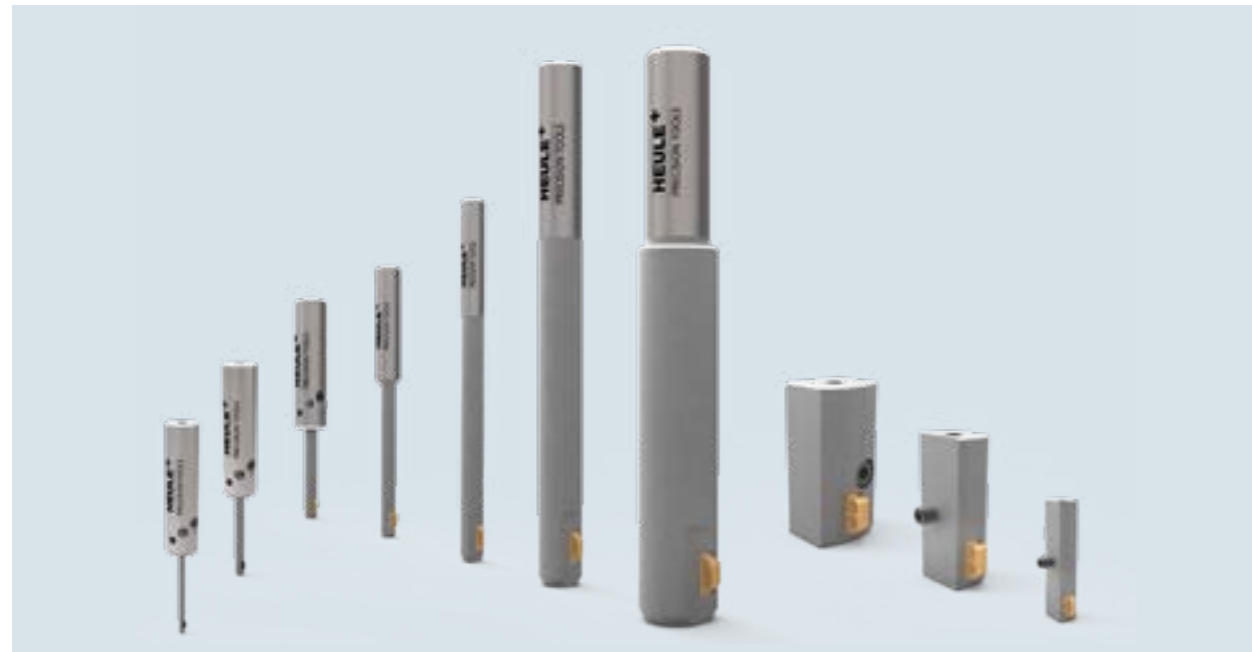

Bore	Max. Chamfering Capacity ¹⁾	Tool Type Series
Ø2.0 – Ø2.9 mm	0.20 - 0.30 mm	SNAP2
Ø3.0 – Ø3.9 mm	0.30 - 0.50 mm	SNAP3
Ø4.0 – Ø5.0 mm	0.60 - 0.75 mm	SNAP4
Ø5.0 – Ø8.0 mm	1.00 mm	SNAP5
Ø8.0 – Ø12.0 mm	0.75 mm	SNAP8
Ø12.0 – Ø20.0 mm	1.00 mm	SNAP12
Ø20.0 - Ø35.0 mm	1.50 mm	SNAP20
from Ø12.6 mm	1.50 mm	SNAP5 Cassette
from Ø25.0 mm	1.50 mm	SNAP20 Cassette
from Ø35.0 mm	1.50 mm	SNAP20 Cassette
Thread M2.5 Ø2.05 mm	0.35 mm	SNAP2/M2.5
Thread M3 Ø2.5 mm	0.45 mm	SNAP2/M3
Thread M4 Ø3.3 mm	0.60 mm	SNAP3/M4
Thread M5 Ø4.2 mm	0.70 mm	SNAP4/M5
Thread M6 Ø5.0 mm	0.75 mm	SNAP5/M6
Thread M8 Ø6.8 mm	0.85 mm	SNAP5/M8
Thread M10 Ø8.5 mm	1.00 mm	SNAP5/M10
Thread M12 Ø10.2 mm	1.15 mm	SNAP5/M12
Thread M14 Ø12.0 mm	1.25 mm	SNAP5/M14

¹⁾ The achievable chamfer capacity varies slightly depending on material, blade force, cutting data or application. The indicated dimension is the theoretically possible maximum.

Part No.: Tool without blade

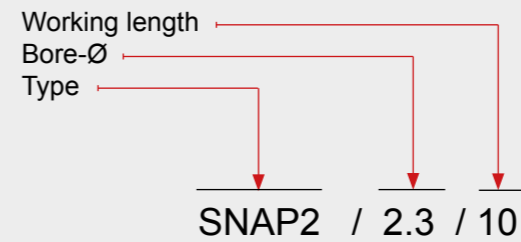

Tool type

Within a tool type there are different tool sizes available. The diameter of the tool housing and the working length vary according to the application.

Tool size

The tool size is determined by the bore diameter. Tool diameter and possible chamfering resp. deburring capacity are shown in the tables (page 68ff).

Working length

For the tool types SNAP2, SNAP3 and SNAP4 there are different working lengths available. The tool types SNAP5 and larger possess only one working length per type. This is why it is not necessary to mention it on the order.

Clamping system

As standard, all tools will be manufactured with a cylindrical shank. Upon request, Weldon, Whistle Notch clamping systems can be ordered for the tool types SNAP5 up to SNAP20 as special versions but these are not available from stock.

If another than the standard shank is requested, please add the following suffixes:

- HB = Weldon
- HE = Whistle Notch

Order Example:
SNAP8/9.5-HB

Part No.: Blade

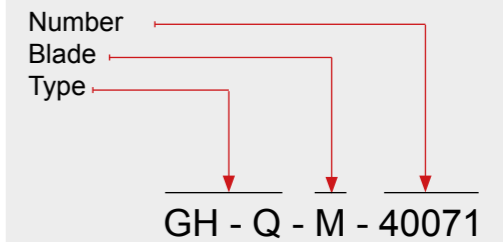

Type

All SNAP blades have the designation GH-Q-M and a consecutive number. These numbers are not based on a system and are therefore without any further information.

Number

Different blades for different chamfer diameters are possible for every tool size (bore-Ø). Hence, the desired chamfer diameter determines the selection of the blade.

Coatings

All blades are made of carbide. The available coatings are:

- T = steel, titan, Inconel (standard)
- D = for aluminium only
- A = increased requirements

An exception form the small tools SNAP2, SNAP3, SNAP4 and SNAP5. Due to the increased requirements the coating A has been defined as standard coating.

Order Example SNAP2, SNAP3, SNAP4

Requirements: Deburr bore,
Chamfer min. 0.1 mm,
Workpiece thickness 18.0 mm

Bore-Ø: 2.6 mm
Material: Cast
Deburr diameter: max. 2.8 mm

Selection:
Tool: Part No. SNAP2/2.6/20
Blade: Part No. GH-Q-M-40071

Order Example SNAP5 up to SNAP20

Requirements: Back bore machining
Chamfer min. 0.5 mm x 45°

Bore-Ø: 11.3 mm
Defined chamfer-Ø: 12.5 mm
Material: Aluminium

Selection:
Tool: Part No. SNAP8/11.0
Blade: Part No. GH-Q-M-05728

SNAP2 Tool Ø 2.0 mm to 2.9 mm

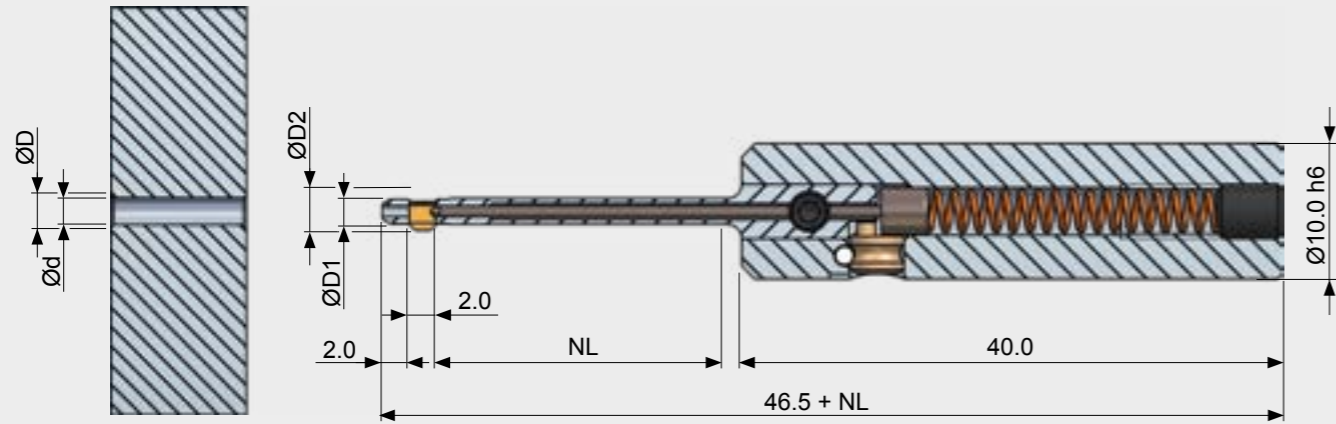

Tool Table

Bore-Ø d	Chamfer-Ø max ¹ D	Tool-Ø D1	Maximum-Ø ² D2	Tool without Blade	
				Part No. NL = 10.0 mm	Part No. NL = 20.0 mm
2.0	2.4	1.95	ØD + 0.2	SNAP2/2.0/10	SNAP2/2.0/20
2.1	2.4 / 2.6	2.05		SNAP2/2.1/10	SNAP2/2.1/20
2.2	2.4 / 2.6 / 2.8	2.15		SNAP2/2.2/10	SNAP2/2.2/20
2.3	2.6 / 2.8	2.25		SNAP2/2.3/10	SNAP2/2.3/20
2.4	2.6 / 2.8 / 3.0	2.35		SNAP2/2.4/10	SNAP2/2.4/20
2.5	2.8 / 3.0	2.45		SNAP2/2.5/10	SNAP2/2.5/20
2.6	2.8 / 3.0 / 3.2	2.55		SNAP2/2.6/10	SNAP2/2.6/20
2.7	3.0 / 3.2	2.65		SNAP2/2.7/10	SNAP2/2.7/20
2.8	3.0 / 3.2 / 3.4	2.75		SNAP2/2.8/10	SNAP2/2.8/20
2.9	3.2 / 3.4	2.85	SNAP2/2.9/10	SNAP2/2.9/20	

¹⁾ Different chamfer-Ø can be achieved per tool size by using different blades. One blade however produces one defined chamfer-Ø only. The achievable chamfer capacity varies slightly depending on material, blade force, cutting data or application. The indicated dimension is the theoretically possible maximum.

²⁾ The maximum diameter D2 varies depending on the selected blade. Please calculate value with formula. **Please mind any interfering edges.**

ORDERING INFORMATION

- The tool types SNAP2, SNAP3 and SNAP4 are available with cylindrical shank only.
- Attention: The tools are **without blade**. The blades for the tool need to be ordered separately. Please refer to page 69 for GS geometry.

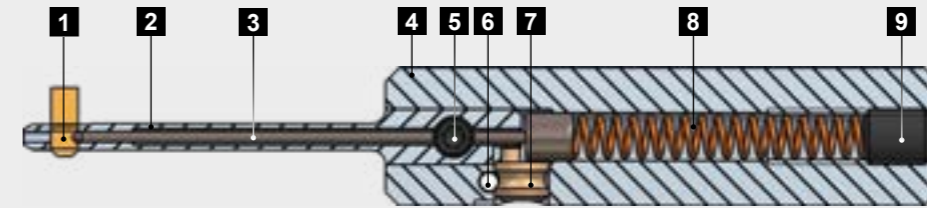

Spare Parts

Pos.	Description	Part No.
1	Blade	see below
2	Blade housing	see page 99
3	Control bolt	GH-Q-E-0236 (NL: 10.0 mm) GH-Q-E-0237 (NL: 20.0 mm)
4	Tool body SNAP2-4 Ø10.0 h6 Tool body assembly SNAP2-4 Ø10.0 h6 incl. Excenter GH-S-E-0031 incl. Roll pin GH-C-E-0811	GH-Q-G-5024 GH-Q-G-5025
5	Locking screw M3x3.3	GH-H-S-1075
6	Roll pin SNAP2-4	GH-C-E-0811
7	Excenter SNAP2-4	GH-S-E-0031
8	Spring Ø3.2xØ0.45x23.0	GH-H-F-0047
9	Set screw M4x5.0 DIN913 Wrench SW1.5 to Pos. 9	GH-H-S-0134 GH-H-S-2101

Blades GS Geometry 90°

Chamfer-Ø ¹	Part No. forward and backward cutting		Part No. backward cutting only	
	Coating A	Coating D	Coating A	Coating D
2.4	GH-Q-M-40031*	GH-Q-M-40032	GH-Q-M-40631	GH-Q-M-40632
2.6	GH-Q-M-40051*	GH-Q-M-40052	GH-Q-M-40651	GH-Q-M-40652
2.8	GH-Q-M-40071*	GH-Q-M-40072	GH-Q-M-40671	GH-Q-M-40672
3.0	GH-Q-M-40091*	GH-Q-M-40092	GH-Q-M-40691	GH-Q-M-40692
3.2	GH-Q-M-40111*	GH-Q-M-40112	GH-Q-M-40711	GH-Q-M-40712
3.4	GH-Q-M-40131*	GH-Q-M-40132	GH-Q-M-40731	GH-Q-M-40732

* Standard items / Please enquire about stock or delivery times for all non-standard items.

¹⁾ The indicated dimension is the theoretically possible maximum.

Explanations to coatings (please refer to page 67)

- A: Coating for steel, titanium, Inconel
- D: Coating for aluminium alloys only

SNAP3 Tool Ø 3.0 mm to 3.9 mm

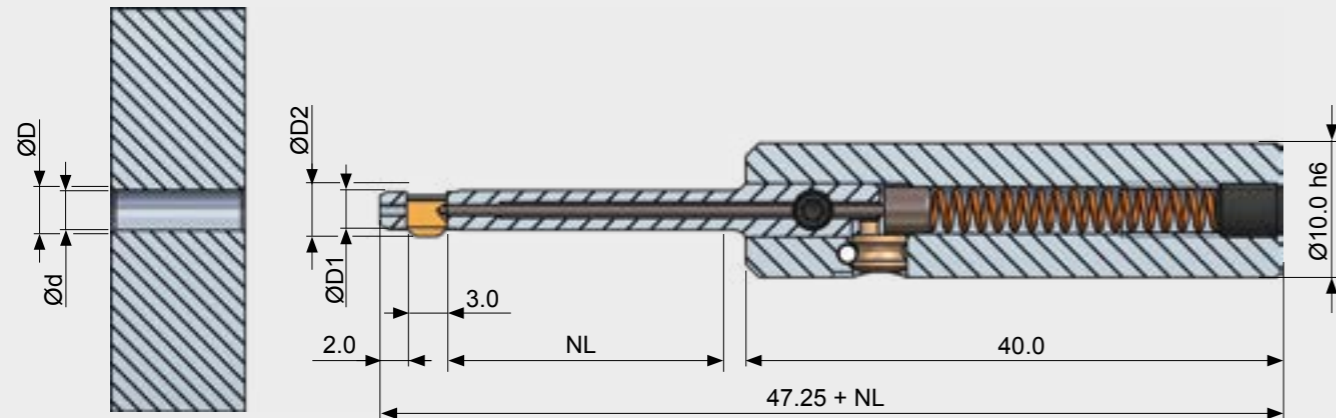

Tool Table

Bore-Ø d	Chamf.-Ø ^{max¹} D	Tool-Ø D1	Max.-Ø ² D2	Tool without Blade		
				Part No. NL = 10.0 mm	Part No. NL = 20.0 mm	Part No. NL = 30.0 mm
3.0	3.3 / 3.6	2.9	ØD + 0.3	SNAP3/3.0/10	SNAP3/3.0/20	SNAP3/3.0/30
3.1	3.6 / 3.9	3.0		SNAP3/3.1/10	SNAP3/3.1/20	SNAP3/3.1/30
3.2	3.6 / 3.9 / 4.2	3.1		SNAP3/3.2/10	SNAP3/3.2/20	SNAP3/3.2/30
3.3	3.9 / 4.2	3.2		SNAP3/3.3/10	SNAP3/3.3/20	SNAP3/3.3/30
3.4	3.9 / 4.2	3.3		SNAP3/3.4/10	SNAP3/3.4/20	SNAP3/3.4/30
3.5	3.9 / 4.2 / 4.5	3.4		SNAP3/3.5/10	SNAP3/3.5/20	SNAP3/3.5/30
3.6	4.2 / 4.5	3.5		SNAP3/3.6/10	SNAP3/3.6/20	SNAP3/3.6/30
3.7	4.2 / 4.5	3.6		SNAP3/3.7/10	SNAP3/3.7/20	SNAP3/3.7/30
3.8	4.2 / 4.5 / 4.8	3.7		SNAP3/3.8/10	SNAP3/3.8/20	SNAP3/3.8/30
3.9	4.5 / 4.8	3.8		SNAP3/3.9/10	SNAP3/3.9/20	SNAP3/3.9/30

¹⁾ Different chamfer-Ø can be achieved per tool size by using different blades. One blade however produces one defined chamfer-Ø only. The achievable chamfer capacity varies slightly depending on material, blade force, cutting data or application. The indicated dimension is the theoretically possible maximum.

²⁾ The maximum diameter D2 varies depending on the selected blade. Please calculate value with formula. **Please mind any interfering edges.**

ORDERING INFORMATION

- The tool types SNAP2, SNAP3 and SNAP4 are available with cylindrical shank only.
- Attention: The tools are **without blade**. The blades for the tool need to be ordered separately. Please refer to page 71 for GS geometry.

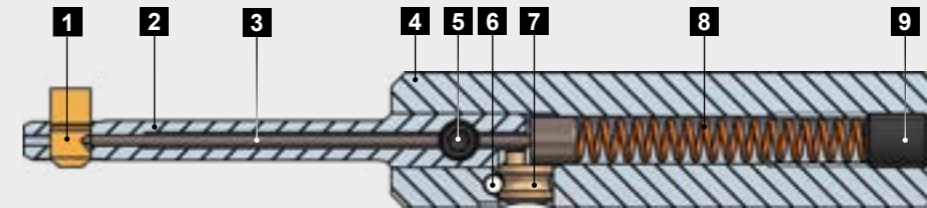

Spare Parts

Pos.	Description	Part No.
1	Blade	see below
2	Blade housing	see page 99
3	Control bolt	GH-Q-E-0236 (NL: 10.0 mm) GH-Q-E-0237 (NL: 20.0 mm) GH-Q-E-0238 (NL: 30.0 mm)
4	Tool body SNAP2-4 Ø10.0 h6	GH-Q-G-5024
	Tool body assembly SNAP2-4 Ø10.0 h6 incl. Excenter GH-S-E-0031 incl. Roll pin GH-C-E-0811	GH-Q-G-5025
5	Locking screw M3x3.3	GH-H-S-1075
6	Roll pin SNAP2-4	GH-C-E-0811
7	Excenter SNAP2-4	GH-S-E-0031
8	Spring Ø3.2xØ0.45x23.0	GH-H-F-0047
9	Set screw M4x5.0 DIN913	GH-H-S-0134
	Wrench SW1.5 zu Pos. 9	GH-H-S-2101

Blades GS Geometry 90°

Chamfer-Ø ¹	Part No. forward and backward cutting		Part No. backward cutting only	
	Coating A	Coating D	Coating A	Coating D
3.3	GH-Q-M-40171*	GH-Q-M-40172	GH-Q-M-40771	GH-Q-M-40772
3.6	GH-Q-M-40201*	GH-Q-M-40202	GH-Q-M-40801	GH-Q-M-40802
3.9	GH-Q-M-40231*	GH-Q-M-40232	GH-Q-M-40831	GH-Q-M-40832
4.2	GH-Q-M-40261*	GH-Q-M-40262	GH-Q-M-40861	GH-Q-M-40862
4.5	GH-Q-M-40291*	GH-Q-M-40292	GH-Q-M-40891	GH-Q-M-40892
4.8	GH-Q-M-40321*	GH-Q-M-40322	GH-Q-M-40921	GH-Q-M-40922

*) **Standard items** / Please enquire about stock or delivery times for all non-standard items.

¹⁾ The indicated dimension is the theoretically possible maximum.

Explanations to coatings (please refer to page 67)

- A: Coating for steel, titanium, Inconel
- D: Coating for aluminium alloys only

SNAP4 Tool Ø 4.0 mm to 5.0 mm

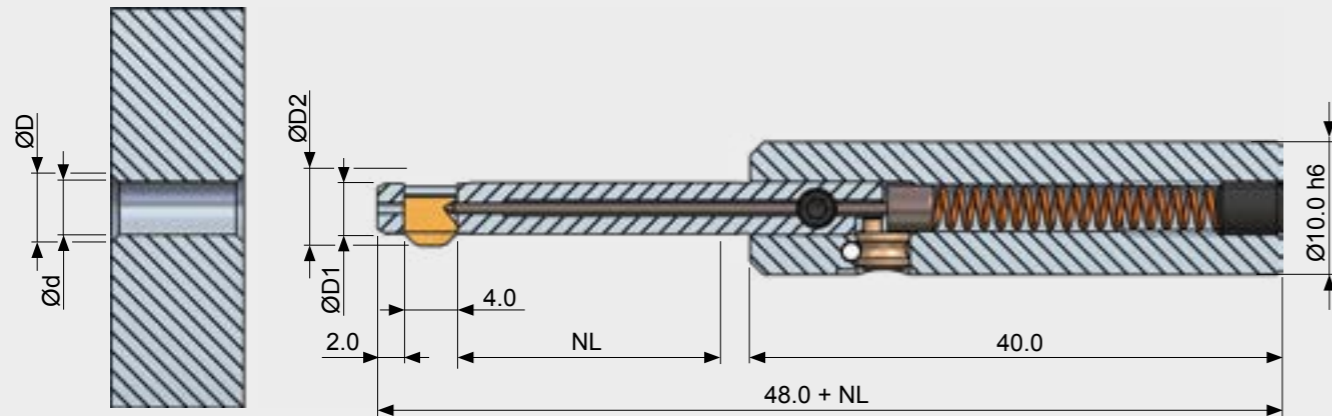

Tool Table

Bore-Ø d	Chamf.-Ø ^{max¹} D	Tool-Ø D1	Max.-Ø ² D2	Tool without Blade		
				Part No. NL = 10.0 mm	Part No. NL = 20.0 mm	Part No. NL = 30.0 mm
4.0	4.4 / 4.8 / 5.2	3.9	ØD + 0.4	SNAP4/4.0/10	SNAP4/4.0/20	SNAP4/4.0/30
4.1	4.8 / 5.2 / 5.6	4.0		SNAP4/4.1/10	SNAP4/4.1/20	SNAP4/4.1/30
4.2	4.8 / 5.2 / 5.6	4.1		SNAP4/4.2/10	SNAP4/4.2/20	SNAP4/4.2/30
4.3	4.8 / 5.2 / 5.6	4.2		SNAP4/4.3/10	SNAP4/4.3/20	SNAP4/4.3/30
4.4	4.8 / 5.2 / 5.6	4.3		SNAP4/4.4/10	SNAP4/4.4/20	SNAP4/4.4/30
4.5	5.2 / 5.6 / 6.0	4.4		SNAP4/4.5/10	SNAP4/4.5/20	SNAP4/4.5/30
4.6	5.2 / 5.6 / 6.0	4.5		SNAP4/4.6/10	SNAP4/4.6/20	SNAP4/4.6/30
4.7	5.2 / 5.6 / 6.0	4.6		SNAP4/4.7/10	SNAP4/4.7/20	SNAP4/4.7/30
4.8	5.2 / 5.6 / 6.0	4.7		SNAP4/4.8/10	SNAP4/4.8/20	SNAP4/4.8/30
4.9	5.6 / 6.0 / 6.4	4.8		SNAP4/4.9/10	SNAP4/4.9/20	SNAP4/4.9/30
5.0	5.6 / 6.0 / 6.4	4.9	SNAP4/5.0/10	SNAP4/5.0/20	SNAP4/5.0/30	

¹⁾ Different chamfer-Ø can be achieved per tool size by using different blades. One blade however produces one defined chamfer-Ø only. The achievable chamfer capacity varies slightly depending on material, blade force, cutting data or application. The indicated dimension is the theoretically possible maximum.

²⁾ The maximum diameter D2 varies depending on the selected blade. Please calculate value with formula. **Please mind any interfering edges.**

ORDERING INFORMATION

- The tool types SNAP2, SNAP3 and SNAP4 are available with cylindrical shank only.
- Attention: The tools are **without blade**. The blades for the tool need to be ordered separately. Please refer to page 73 for GS geometry.

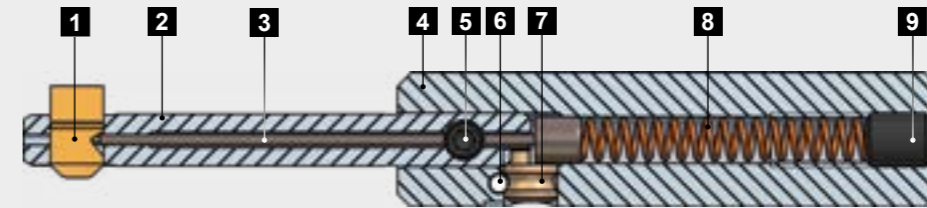

Spare Parts

Pos.	Description	Part No.
1	Blade	see below
2	Blade housing	see page 99
3	Control bolt	GH-Q-E-0236 (NL: 10.0 mm) GH-Q-E-0237 (NL: 20.0 mm) GH-Q-E-0238 (NL: 30.0 mm)
4	Tool body SNAP2-4 Ø10.0 h6	GH-Q-G-5024
	Tool body assembly SNAP2-4 Ø10.0 h6 incl. Excenter GH-S-E-0031 incl. Roll pin GH-C-E-0811	GH-Q-G-5025
5	Locking pin M3x3.3	GH-H-S-1075
6	Roll pin SNAP2-4	GH-C-E-0811
7	Excenter SNAP2-4	GH-S-E-0031
8	Spring Ø3.2xØ0.45x23.0	GH-H-F-0047
9	Set screw M4x5.0 DIN913	GH-H-S-0134
	Wrench SW1.5 zu Pos. 9	GH-H-S-2101

Blades GS Geometry 90°

Chamfer-Ø ¹	Part No. forward and backward cutting		Part No. backward cutting only	
	Coating A	Coating D	Coating A	Coating D
4.4	GH-Q-M-40381*	GH-Q-M-40382	GH-Q-M-40981	GH-Q-M-40982
4.8	GH-Q-M-40421*	GH-Q-M-40422	GH-Q-M-41021	GH-Q-M-41022
5.2	GH-Q-M-40461*	GH-Q-M-40462	GH-Q-M-41061	GH-Q-M-41062
5.6	GH-Q-M-40501*	GH-Q-M-40502	GH-Q-M-41101	GH-Q-M-41102
6.0	GH-Q-M-40541*	GH-Q-M-40542	GH-Q-M-41141	GH-Q-M-41142
6.4	GH-Q-M-40581*	GH-Q-M-40582	GH-Q-M-41181	GH-Q-M-41182

* **Standard items** / Please enquire about stock or delivery times for all non-standard items.

¹⁾ The indicated dimension is the theoretically possible maximum.

Explanations to coatings (please refer to page 67)

- A: Coating for steel, titanium, Inconel
- D: Coating for aluminium alloys only

SNAP5 Tool Ø 5.0 mm to 10.0 mm

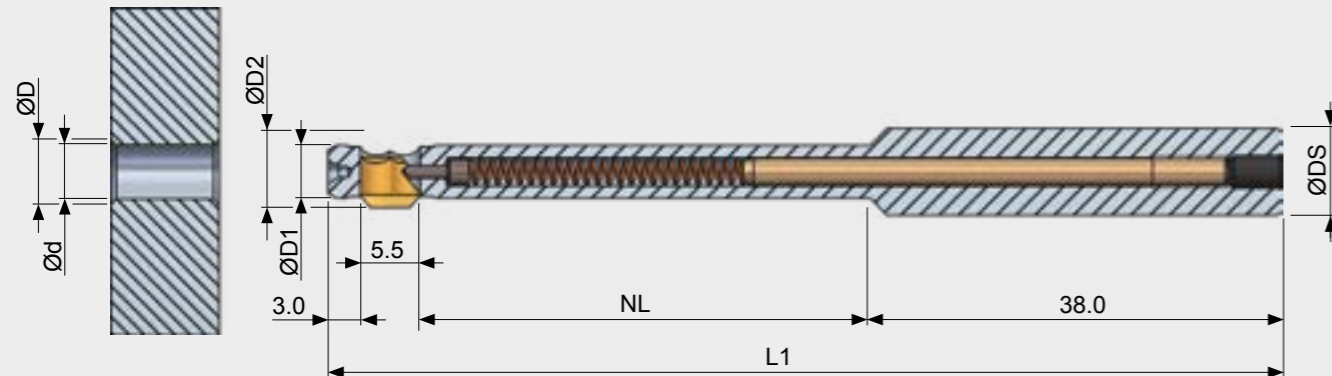

Tool Table

Bore-Ø d	Chamfer-Ø max. ¹ D	Tool-Ø D1	Max-Ø ² D2	Tool length L1	Work length NL	Shank-Ø DS	Tool without Blade Part No.
5.0-5.5	5.5 / 6.0 / 6.5 / 7.0	4.9	ØD+0.6	88.0	40.0	8.0 h6	SNAP5/5.0
5.5-6.0	6.0 / 6.5 / 7.0 / 7.5	5.4		88.0	40.0	8.0 h6	SNAP5/5.5
6.0-6.5	6.5 / 7.0 / 7.5 / 8.0	5.9		88.0	40.0	8.0 h6	SNAP5/6.0
6.5-7.0	7.0 / 7.5 / 8.0 / 8.5	6.4		88.0	40.0	8.0 h6	SNAP5/6.5
7.0-7.5	7.5 / 8.0 / 8.5 / 9.0	6.9		88.0	40.0	8.0 h6	SNAP5/7.0
7.5-8.0	8.0 / 8.5 / 9.0 / 9.5	7.4		88.0	40.0	8.0 h6	SNAP5/7.5
8.0-8.5	8.5 / 9.0 / 9.5 / 10.0	7.8		98.0	50.0	10.0 h6	SNAP5/8.0
8.5-9.0	9.0 / 9.5 / 10.0 / 10.5	8.3		98.0	50.0	10.0 h6	SNAP5/8.5
9.0-9.5	9.5 / 10.0 / 10.5 / 11.0	8.8		98.0	50.0	10.0 h6	SNAP5/9.0
9.5-10.0	10.0 / 10.5 / 11.0 / 11.5	9.3		98.0	50.0	10.0 h6	SNAP5/9.5
10.0-10.5	10.5 / 11.0 / 11.5 / 12.0	9.8	107.0	50.0	12.0 h6	SNAP5/10.0	

¹⁾ Different chamfer-Ø can be achieved per tool size by using different blades. One blade however produces one defined chamfer-Ø only. The achievable chamfer capacity varies slightly depending on material, blade force, cutting data or application. The indicated dimension is the theoretically possible maximum.

²⁾ The maximum diameter D2 varies depending on the selected blade. Please calculate value with formula. **Please mind any interfering edges.**

ORDERING INFORMATION

- Standard shank for tool part numbers without any addition = Cylindrical shank
With addition: "-HB" = Weldon shank or "-HE" = Whistle Notch shank (see page 67)
- Attention: The tools are **without blade**. The blades for the tool need to be ordered separately. Please refer to page 75 for GS geometry.

Attention:
Blades for SNAP5 tools and blades for Thread tools are **not** interchangeable!

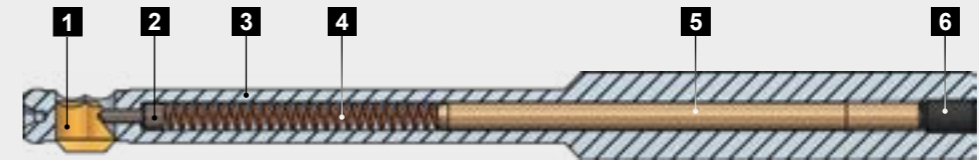

Spare parts

Pos.	Description	Part No.
1	Blade	see below
2	Control bolt Ø1.2	GH-Q-E-0008
3	Tool body	see page 100
4	Spring Ø2.35 x Ø0.35 x 30.0	GH-H-F-0019
5	SNAP Distance pin Ø2.5 x 45.0	GH-Q-E-0041
	SNAP Distance pin Ø2.5 x 55.0	GH-Q-E-0068
	SNAP Distance pin Ø2.5 x 65.0	GH-Q-E-0067
6	Set screw M3 x 5.0 DIN 913	GH-H-S-0127
	Wrench SW1.5 to Pos. 6 (not included)	GH-H-S-2101

Blades GS Geometry 90°

Chamfer-Ø ¹	Part No. forward and backward cutting		backward cutting only	
	Coating A	Coating D	Coating A	Coating D
5.5	GH-Q-M-30204*	GH-Q-M-30404	GH-Q-M-31204	GH-Q-M-31404
6.0	GH-Q-M-30205*	GH-Q-M-30405	GH-Q-M-31205	GH-Q-M-31405
6.5	GH-Q-M-30206*	GH-Q-M-30406	GH-Q-M-31206	GH-Q-M-31406
7.0	GH-Q-M-30207*	GH-Q-M-30407	GH-Q-M-31207	GH-Q-M-31407
7.5	GH-Q-M-30208*	GH-Q-M-30408	GH-Q-M-31208	GH-Q-M-31408
8.0	GH-Q-M-30209*	GH-Q-M-30409	GH-Q-M-31209	GH-Q-M-31409
8.5	GH-Q-M-30210*	GH-Q-M-30410	GH-Q-M-31210	GH-Q-M-31410
9.0	GH-Q-M-30211*	GH-Q-M-30411	GH-Q-M-31211	GH-Q-M-31411
9.5	GH-Q-M-30212*	GH-Q-M-30412	GH-Q-M-31212	GH-Q-M-31412
10.0	GH-Q-M-30213*	GH-Q-M-30413	GH-Q-M-31213	GH-Q-M-31413
10.5	GH-Q-M-30214*	GH-Q-M-30414	GH-Q-M-31214	GH-Q-M-31414
11.0	GH-Q-M-30215*	GH-Q-M-30415	GH-Q-M-31215	GH-Q-M-31415
11.5	GH-Q-M-30216*	GH-Q-M-30416	GH-Q-M-31216	GH-Q-M-31416
12.0	GH-Q-M-30217*	GH-Q-M-30417	GH-Q-M-31217	GH-Q-M-31417

* **Standard items** / Please enquire about stock or delivery times for all non-standard items.

¹⁾ The indicated dimension is the theoretically possible maximum.

Explanations to coatings (please refer to page 67)

- A: Coating for steel, titanium, Inconel
- D: Coating for aluminium alloys only

SNAP8 Tool Ø 8.0 mm to 12.0 mm

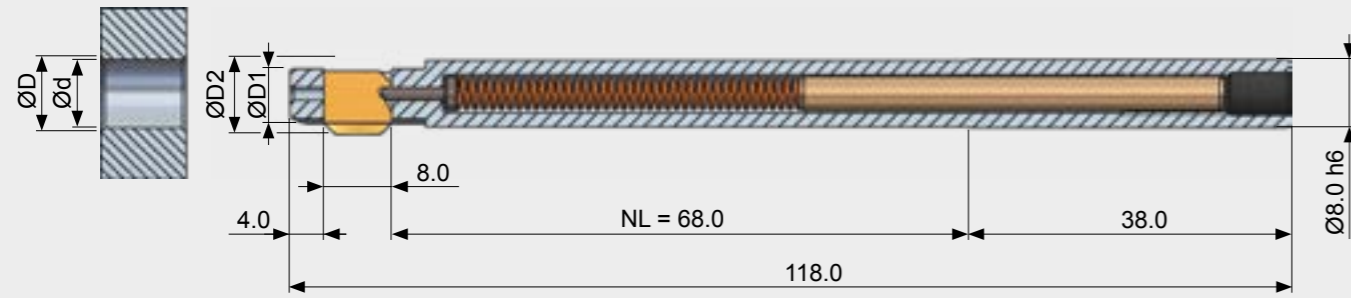

Tool Table

Bore-Ø d	Chamfer-Ø max. ¹ D	Tool-Ø D1	Max-Ø ² D2	Tool without Blade
				Part No.
8.0 - 8.5	8.5 / 9.0 / 9.5	7.8	ØD + 0.6	SNAP8/8.0
8.5 - 9.0	9.0 / 9.5 / 10.0	8.3		SNAP8/8.5
9.0 - 9.5	9.5 / 10.0 / 10.5	8.8		SNAP8/9.0
9.5 - 10.0	10.0 / 10.5 / 11.0	9.3		SNAP8/9.5
10.0 - 10.5	10.5 / 11.0 / 11.5	9.8		SNAP8/10.0
10.5 - 11.0	11.0 / 11.5 / 12.0	10.3		SNAP8/10.5
11.0 - 11.5	11.5 / 12.0 / 12.5	10.8		SNAP8/11.0
11.5 - 12.0	12.0 / 12.5 / 13.0	11.3		SNAP8/11.5
12.0 - 12.5	12.5 / 13.0 / 13.5	11.8		SNAP8/12.0

¹ Different chamfer-Ø can be achieved per tool size by using different blades. One blade however produces one defined chamfer-Ø only. The achievable chamfer capacity varies slightly depending on material, blade force, cutting data or application. The indicated dimension is the theoretically possible maximum.

² The maximum diameter D2 varies depending on the selected blade. Please calculate value with formula. **Please mind any interfering edges.**

ORDERING INFORMATION

- Standard shank for tool part numbers without any addition = Cylindrical shank
With addition: "-HB" = Weldon shank or "-HE" = Whistle Notch shank (see page 67)
- Attention: The tools are **without blade**. The blades for the tool need to be ordered separately.
Please refer to page 77 for GS geometry and to page 91 for DF geometry.

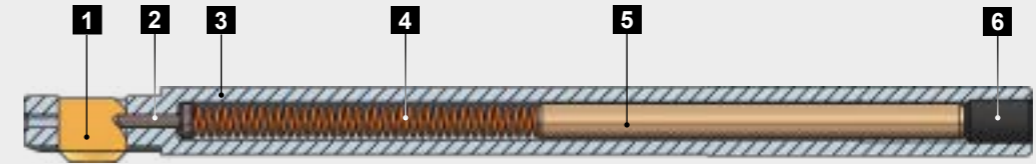

Spare Parts

Pos.	Description	Part No.
1	Blade	see below
2	Control bolt Ø1.5	GH-Q-E-0002
3	Tool body	see page 100
4	Spring Ø3.7 x Ø0.5 x 48.0	GH-H-F-0007
5	SNAP Distance pin Ø4 x 50.0	GH-Q-E-0028
6	Set screw M5 x 8.0 DIN 913 Wrench SW2.5 to Pos. 6 (not included)	GH-H-S-0119 GH-H-S-2100

Blades GS Geometry 90°

Chamfer-Ø ¹	Part No. forward and backward cutting		backward cutting only	
	Coating T	Coating A	Coating T	Coating A
8.5	GH-Q-M-03720*	GH-Q-M-03820	GH-Q-M-05720	GH-Q-M-05820
9.0	GH-Q-M-03721*	GH-Q-M-03821	GH-Q-M-05721	GH-Q-M-05821
9.5	GH-Q-M-03722*	GH-Q-M-03822	GH-Q-M-05722	GH-Q-M-05822
10.0	GH-Q-M-03723*	GH-Q-M-03823	GH-Q-M-05723	GH-Q-M-05823
10.5	GH-Q-M-03724*	GH-Q-M-03824	GH-Q-M-05724	GH-Q-M-05824
11.0	GH-Q-M-03725*	GH-Q-M-03825	GH-Q-M-05725	GH-Q-M-05825
11.5	GH-Q-M-03726*	GH-Q-M-03826	GH-Q-M-05726	GH-Q-M-05826
12.0	GH-Q-M-03727*	GH-Q-M-03827	GH-Q-M-05727	GH-Q-M-05827
12.5	GH-Q-M-03728*	GH-Q-M-03828	GH-Q-M-05728	GH-Q-M-05828
13.0	GH-Q-M-03729*	GH-Q-M-03829	GH-Q-M-05729	GH-Q-M-05829
13.5	GH-Q-M-03730*	GH-Q-M-03830	GH-Q-M-05730	GH-Q-M-05830

*¹ Standard items / Please enquire about stock or delivery times for all non-standard items.

¹ The indicated dimension is the theoretically possible maximum.

Explanations to coating (please refer to page 67)

- T: Standard coating
- A: Coating for increased requirements

Blade range with DF geometry (please refer to page 91)

SNAP12 Tool Ø 12.0mm to 20.0 mm

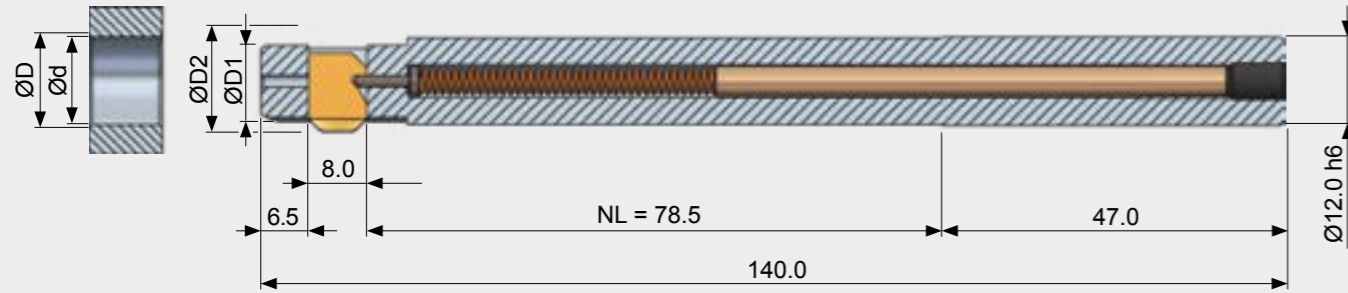

Tool Table

Bore-Ø d	Chamfer-Ø max. ¹ D	Tool-Ø D1	Max-Ø ² D2	Part No.
12.0 - 13.5	12.5 / 13.0 / 13.5 / 14.0	11.8	ØD + 0.8	SNAP12/12.0
12.5 - 14.0	13.0 / 13.5 / 14.0 / 14.5	12.3		SNAP12/12.5
13.0 - 14.5	13.5 / 14.0 / 14.5 / 15.0	12.8		SNAP12/13.0
13.5 - 15.0	14.0 / 14.5 / 15.0 / 15.5	13.3		SNAP12/13.5
14.0 - 15.5	14.5 / 15.0 / 15.5 / 16.0	13.8		SNAP12/14.0
14.5 - 16.0	15.0 / 15.5 / 16.0 / 16.5	14.3		SNAP12/14.5
15.0 - 16.5	15.5 / 16.0 / 16.5 / 17.0	14.8		SNAP12/15.0
15.5 - 17.0	16.0 / 16.5 / 17.0 / 17.5	15.3		SNAP12/15.5
16.0 - 17.5	16.5 / 17.0 / 17.5 / 18.0	15.8		SNAP12/16.0
16.5 - 18.0	17.0 / 17.5 / 18.0 / 18.5	16.3		SNAP12/16.5
17.0 - 18.5	17.5 / 18.0 / 18.5 / 19.0	16.8		SNAP12/17.0
17.5 - 19.0	18.0 / 18.5 / 19.0 / 19.5	17.3		SNAP12/17.5
18.0 - 19.5	18.5 / 19.0 / 19.5 / 20.0	17.8		SNAP12/18.0
18.5 - 20.0	19.0 / 19.5 / 20.0 / 20.5	18.3		SNAP12/18.5
19.0 - 20.5	19.5 / 20.0 / 20.5 / 21.0	18.8		SNAP12/19.0
19.5 - 21.0	20.0 / 20.5 / 21.0 / 21.5	19.3		SNAP12/19.5
20.0 - 21.5	20.5 / 21.0 / 21.5 / 22.0	19.8		SNAP12/20.0

¹ Different chamfer-Ø can be achieved per tool size by using different blades. One blade however produces one defined chamfer-Ø only. The achievable chamfer capacity varies slightly depending on material, blade force, cutting data or application. The indicated dimension is the theoretically possible maximum.

² The maximum diameter D2 varies depending on the selected blade. Please calculate value with formula. **Please mind any interfering edges.**

ORDERING INFORMATION:

- Standard shank for tool part numbers without any addition = Cylindrical shank
With addition: "-HB" = Weldon shank or "-HE" = Whistle Notch shank (see page 67)
- Attention: The tools are **without blade**. The blades for the tool need to be ordered separately.
Please refer to page 79 for GS geometry and to page 91 for DF geometry.



Spare Parts

Pos.	Description	Part No.
1	Blade	see below
2	Control bolt Ø1.5	GH-Q-E-0002
3	Tool body	see page 100
4	Spring Ø3.7 x Ø0.5 x 48.0	GH-H-F-0007
5	SNAP Distance pin Ø4.0 x 70.0	GH-Q-E-0032
6	Set screw M5 x 8.0 DIN 913 Wrench SW2.5 to Pos. 6 (not included)	GH-H-S-0119 GH-H-S-2100

Pos.1 Blades GS Geometry 90°

Chamfer-Ø ¹	Part No. forward and backward cutting		backward cutting only	
	Coating T	Coating A	Coating T	Coating A
12.5	GH-Q-M-03740*	GH-Q-M-03840	GH-Q-M-05740	GH-Q-M-05840
13.0	GH-Q-M-03741*	GH-Q-M-03841	GH-Q-M-05741	GH-Q-M-05841
13.5	GH-Q-M-03742*	GH-Q-M-03842	GH-Q-M-05742	GH-Q-M-05842
14.0	GH-Q-M-03743*	GH-Q-M-03843	GH-Q-M-05743	GH-Q-M-05843
14.5	GH-Q-M-03744*	GH-Q-M-03844	GH-Q-M-05744	GH-Q-M-05844
15.0	GH-Q-M-03745*	GH-Q-M-03845	GH-Q-M-05745	GH-Q-M-05845
15.5	GH-Q-M-03746*	GH-Q-M-03846	GH-Q-M-05746	GH-Q-M-05846
16.0	GH-Q-M-03747*	GH-Q-M-03847	GH-Q-M-05747	GH-Q-M-05847
16.5	GH-Q-M-03748*	GH-Q-M-03848	GH-Q-M-05748	GH-Q-M-05848
17.0	GH-Q-M-03749*	GH-Q-M-03849	GH-Q-M-05749	GH-Q-M-05849
17.5	GH-Q-M-03750*	GH-Q-M-03850	GH-Q-M-05750	GH-Q-M-05850
18.0	GH-Q-M-03751*	GH-Q-M-03851	GH-Q-M-05751	GH-Q-M-05851
18.5	GH-Q-M-03752*	GH-Q-M-03852	GH-Q-M-05752	GH-Q-M-05852
19.0	GH-Q-M-03753*	GH-Q-M-03853	GH-Q-M-05753	GH-Q-M-05853
19.5	GH-Q-M-03754*	GH-Q-M-03854	GH-Q-M-05754	GH-Q-M-05854
20.0	GH-Q-M-03755*	GH-Q-M-03855	GH-Q-M-05755	GH-Q-M-05855
20.5	GH-Q-M-03756*	GH-Q-M-03856	GH-Q-M-05756	GH-Q-M-05856
21.0	GH-Q-M-03757*	GH-Q-M-03857	GH-Q-M-05757	GH-Q-M-05857
21.5	GH-Q-M-03758*	GH-Q-M-03858	GH-Q-M-05758	GH-Q-M-05858
22.0	GH-Q-M-03759*	GH-Q-M-03859	GH-Q-M-05759	GH-Q-M-05859

* Standard items / Please enquire about stock or delivery times for all non-standard items.

¹ The indicated dimension is the theoretically possible maximum.

Explanations to coating (please refer to page 67)

- T: Standard coating
- A: Coating for increased requirements

Blade range with DF geometry (please refer to page 91)

SNAP20 Tool Ø 20.0mm to 35.0 mm

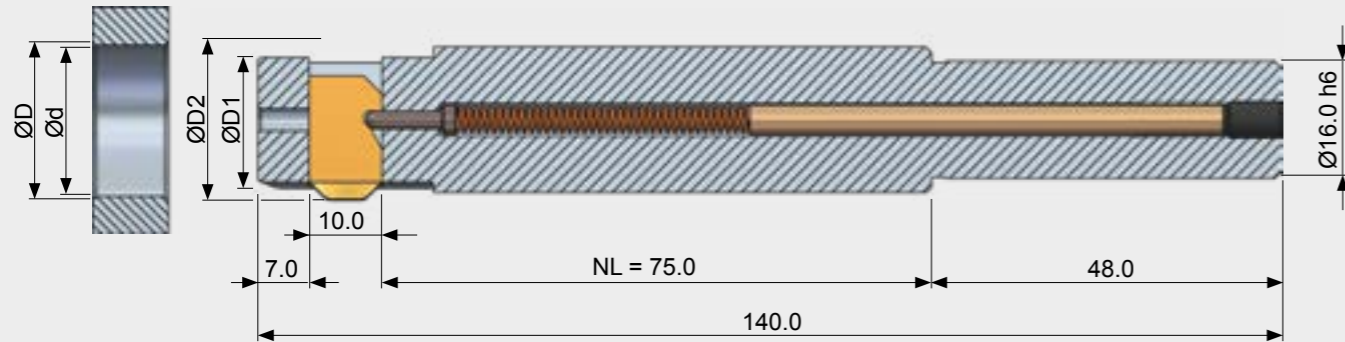

Tool Table

Bore-Ø d	Chamfer-Ø max. ¹ D	Tool-Ø D1	Max.-Ø ² D2	Tool without Blade
				Part No.
20.0-22.5	21.0 / 22.0 / 23.0	19.8	ØD + 1.0	SNAP20/20.0
21.0-23.5	22.0 / 23.0 / 24.0	20.8		SNAP20/21.0
22.0-24.5	23.0 / 24.0 / 25.0	21.8		SNAP20/22.0
23.0-25.5	24.0 / 25.0 / 26.0	22.8		SNAP20/23.0
24.0-26.5	25.0 / 26.0 / 27.0	23.8		SNAP20/24.0
25.0-27.5	26.0 / 27.0 / 28.0	24.8		SNAP20/25.0
26.0-28.5	27.0 / 28.0 / 29.0	25.8		SNAP20/26.0
27.0-29.5	28.0 / 29.0 / 30.0	26.8		SNAP20/27.0
28.0-30.5	29.0 / 30.0 / 31.0	27.8		SNAP20/28.0
29.0-31.5	30.0 / 31.0 / 32.0	28.8		SNAP20/29.0
30.0-32.5	31.0 / 32.0 / 33.0	29.8		SNAP20/30.0
31.0-33.5	32.0 / 33.0 / 34.0	30.8		SNAP20/31.0
32.0-34.5	33.0 / 34.0 / 35.0	31.8		SNAP20/32.0
33.0-35.5	34.0 / 35.0 / 36.0	32.8		SNAP20/33.0
34.0-36.5	35.0 / 36.0 / 37.0	33.8		SNAP20/34.0
35.0-37.5	36.0 / 37.0 / 38.0	34.8		SNAP20/35.0

¹⁾ Different chamfer-Ø can be achieved per tool size by using different blades. One blade however produces one defined chamfer-Ø only. The achievable chamfer capacity varies slightly depending on material, blade force, cutting data or application. The indicated dimension is the theoretically possible maximum.

²⁾ The maximum diameter D2 varies depending on the selected blade. Please calculate value with formula. **Please mind any interfering edges.**

ORDERING INFORMATION:

- Standard shank for tool part numbers without any addition = Cylindrical shank
With addition: "-HB" = Weldon shank or "-HE" = Whistle Notch shank (see page 67)
- Attention: The tools are **without blade**. The blades for the tool need to be ordered separately.
Please refer to page 81 for GS geometry and to page 92 for DF geometry.

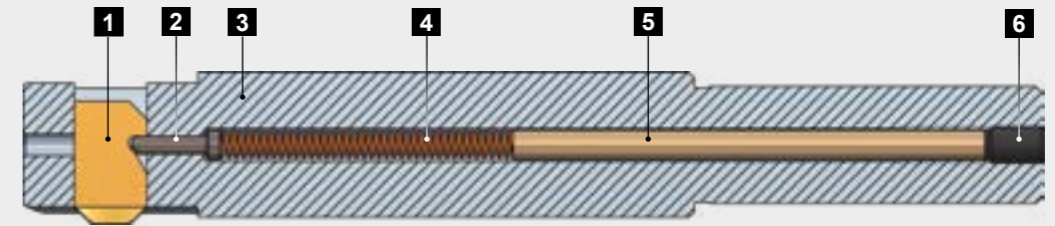

Spare Parts

Pos.	Description	Part No.
1	Blade	see below
2	Control bolt Ø2.5	GH-Q-E-0003
3	Tool body	see page 100f.
4	Spring Ø4.3 x Ø0.6 x 52.0	GH-H-F-0011
5	SNAP Distance pin Ø4 x 65.0	GH-Q-E-0031
6	Set screw M5 x 8.0 DIN 913	GH-H-S-0119
	Wrench SW2.5 to Pos. 6 (not included)	GH-H-S-2100

Blades GS Geometry 90°

Chamfer-Ø ¹	Part No. forward and backward cutting		backward cutting only	
	Coating T	Coating A	Coating T	Coating A
21.0	GH-Q-M-03770*	GH-Q-M-03870	GH-Q-M-05770	GH-Q-M-05870
22.0	GH-Q-M-03771*	GH-Q-M-03871	GH-Q-M-05771	GH-Q-M-05871
23.0	GH-Q-M-03772*	GH-Q-M-03872	GH-Q-M-05772	GH-Q-M-05872
24.0	GH-Q-M-03773*	GH-Q-M-03873	GH-Q-M-05773	GH-Q-M-05873
25.0	GH-Q-M-03774*	GH-Q-M-03874	GH-Q-M-05774	GH-Q-M-05874
26.0	GH-Q-M-03775*	GH-Q-M-03875	GH-Q-M-05775	GH-Q-M-05875
27.0	GH-Q-M-03776*	GH-Q-M-03876	GH-Q-M-05776	GH-Q-M-05876
28.0	GH-Q-M-03777*	GH-Q-M-03877	GH-Q-M-05777	GH-Q-M-05877
29.0	GH-Q-M-03778*	GH-Q-M-03878	GH-Q-M-05778	GH-Q-M-05878
30.0	GH-Q-M-03779*	GH-Q-M-03879	GH-Q-M-05779	GH-Q-M-05879
31.0	GH-Q-M-03780*	GH-Q-M-03880	GH-Q-M-05780	GH-Q-M-05880
32.0	GH-Q-M-03781*	GH-Q-M-03881	GH-Q-M-05781	GH-Q-M-05881
33.0	GH-Q-M-03782*	GH-Q-M-03882	GH-Q-M-05782	GH-Q-M-05882
34.0	GH-Q-M-03783*	GH-Q-M-03883	GH-Q-M-05783	GH-Q-M-05883
35.0	GH-Q-M-03784*	GH-Q-M-03884	GH-Q-M-05784	GH-Q-M-05884
36.0	GH-Q-M-03785*	GH-Q-M-03885	GH-Q-M-05785	GH-Q-M-05885
37.0	GH-Q-M-03786*	GH-Q-M-03886	GH-Q-M-05786	GH-Q-M-05886
38.0	GH-Q-M-03787*	GH-Q-M-03887	GH-Q-M-05787	GH-Q-M-05887

* Standard items / Please enquire about stock or delivery times for all non-standard items.

¹⁾ The indicated dimension is the theoretically possible maximum.

Explanations to coating (please refer to page 67)

- T: Standard coating
- A: Coating for increased requirements

Blade range with DF geometry (please refer to page 92)

SNAP Thread Tool M2.5 / M3 / M4 / M5

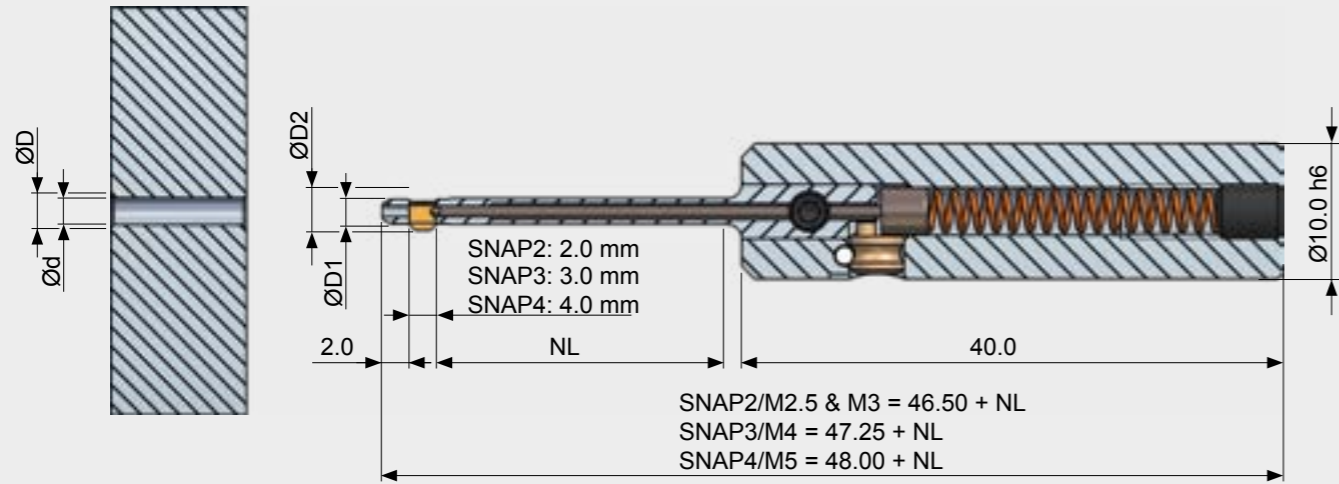

Tool Table

Bore-Ø d	Thread ³	Chamf-Ø ¹ D	Tool-Ø D1	Max.-Ø ² D2	Tool without Blade		
					Part No. NL = 10.0 mm	Part No. NL = 20.0 mm	Part No. NL = 30.0 mm
Ø2.05	M2.5	2.8	2.0	3.0	SNAP2/M2.5/10	SNAP2/M2.5/20	-
Ø2.5	M3	3.4	2.45	3.6	SNAP2/M3/10	SNAP2/M3/20	-
Ø3.3	M4	4.5	3.2	4.8	SNAP3/M4/10	SNAP3/M4/20	SNAP3/M4/30
Ø4.2	M5	5.6	4.1	6.0	SNAP4/M5/10	SNAP4/M5/20	SNAP4/M5/30

¹⁾ The achievable chamfer capacity varies slightly depending on material, blade force, cutting data or application. The indicated dimension is the theoretically possible maximum.

²⁾ Please mind any interfering edges.

³⁾ The tools for the thread types M6, M8, M10, M12, M14 are listed on page 84f.

ORDERING INFORMATION:

- The tool types SNAP2, SNAP3 and SNAP4 are available with cylindrical shank only.
- Attention: The tools are **without blade**. The blades for the tool need to be ordered separately. Please refer to page 83 for GS geometry.

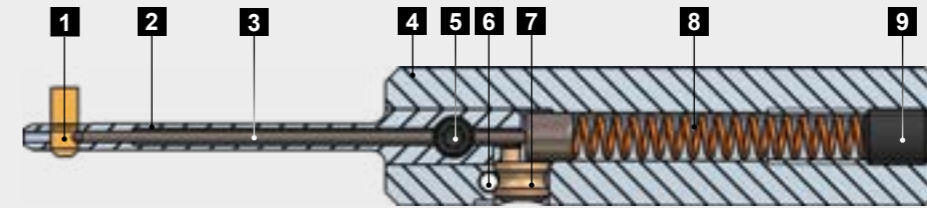

Spare Parts

Pos.	Description	Part No.		
		NL 10.0 mm	NL 20.0 mm	NL 30.0 mm
1	Blade	see below	see below	see below
2	Blade housing SNAP2/M2.5/.. Blade housing SNAP2/M3/.. Blade housing SNAP3/M4/.. Blade housing SNAP4/M5/..	GH-Q-N-0015 GH-Q-N-0016 GH-Q-N-0035 GH-Q-N-0055	GH-Q-N-0075 GH-Q-N-0076 GH-Q-N-0095 GH-Q-N-0115	GH-Q-N-0155 GH-Q-N-0175
3	Control bolt SNAP2/M2.5/.. Control bolt SNAP2/M3/.. Control bolt SNAP3/M4/.. Control bolt SNAP4/M5/..	GH-Q-E-0254 GH-Q-E-0236 GH-Q-E-0236 GH-Q-E-0236	GH-Q-E-0256 GH-Q-E-0237 GH-Q-E-0237 GH-Q-E-0237	GH-Q-E-0238 GH-Q-E-0238
4	Tool body Tool body assembly incl. Excenter GH-S-E-0031 incl. Roll pin GH-C-E-0811	GH-Q-G-5024 GH-Q-G-5025	GH-Q-G-5024 GH-Q-G-5025	GH-Q-G-5024 GH-Q-G-5025
5	Locking screw M3x3.3	GH-H-S-1075	GH-H-S-1075	GH-H-S-1075
6	Roll pin SNAP2-4	GH-C-E-0811	GH-C-E-0811	GH-C-E-0811
7	Excenter SNAP2-4	GH-S-E-0031	GH-S-E-0031	GH-S-E-0031
8	Spring Ø3.2xØ0.45x23.0	GH-H-F-0047	GH-H-F-0047	GH-H-F-0047
9	Set screw M4x5.0 DIN913 Wrench SW1.5 to Pos. 9	GH-H-S-0134 GH-H-S-2101	GH-H-S-0134 GH-H-S-2101	GH-H-S-0134 GH-H-S-2101

Blades GS Geometry 90°

Chamfer-Ø ¹	Part No. forward and backward cutting		Part No. backward cutting only	
	Coating A	Coating D	Coating A	Coating D
Ø2.8	GH-Q-M-41501	GH-Q-M-41502	GH-Q-M-41601	GH-Q-M-41602
Ø3.4	GH-Q-M-41511	GH-Q-M-41512	GH-Q-M-41611	GH-Q-M-41612
Ø4.5	GH-Q-M-41521	GH-Q-M-41522	GH-Q-M-41621	GH-Q-M-41622
Ø5.6	GH-Q-M-41531	GH-Q-M-41532	GH-Q-M-41631	GH-Q-M-41632

¹⁾ The indicated dimension is the theoretically possible maximum.

Explanations to coatings (please refer to page 67)

- A: Coating for increased requirements
- D: Coating for aluminium alloys only - available upon customer request only

SNAP Thread Tool M6 / M8 / M10 / M12 / M14

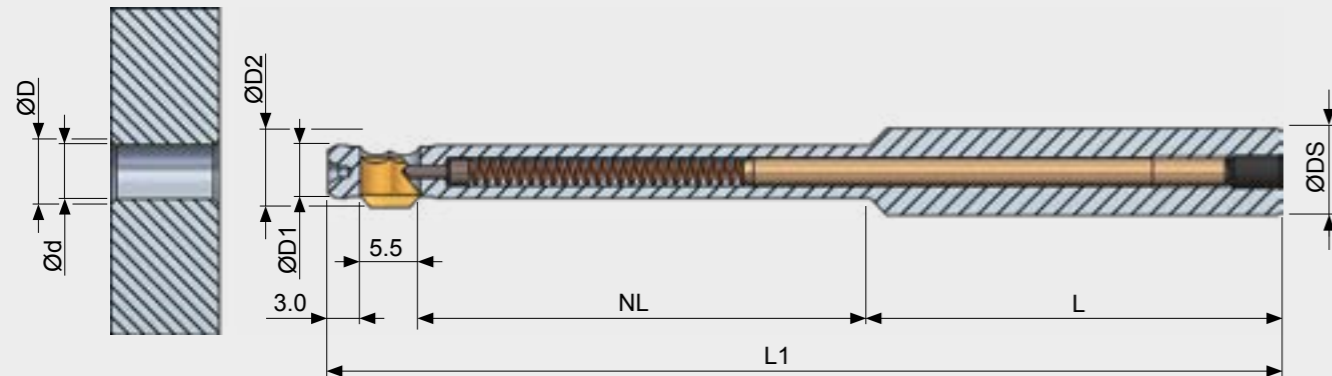

Tool Table

Bore-Ø d	Thread ³	Chamfer-Ø ¹ D	Tool-Ø D1	Max-Ø ² D2	Tool length L1	Work. length NL	Shank L	Shank-Ø DS	Tool without Blade Part No.
5.0	M6	6.5	4.9	7.3	88.0	40.0	38.0	8.0 h6	SNAP5/M6
6.8	M8	8.5	6.7	9.3	88.0	40.0	38.0	8.0 h6	SNAP5/M8
8.5	M10	10.5	8.3	11.3	100.0	50.0	40.0	10.0 h6	SNAP5/M10
10.2	M12	12.5	10.0	13.1	100.0	50.0	40.0	10.0 h6	SNAP5/M12
12.0	M14	14.5	11.8	15.1	100.0	50.0	40.0	10.0 h6	SNAP5/M14

¹⁾ The achievable chamfer capacity varies slightly depending on material, blade force, cutting data or application. The indicated dimension is the theoretically possible maximum.

²⁾ Please mind any interfering edges.

³⁾ The tools for thread types M2.5, M3, M4, M5 are on page 82f.

ORDERING INFORMATION

- Standard shank for tool part numbers without any addition = Cylindrical shank
With addition: "-HB" = Weldon shank or "-HE" = Whistle Notch shank (please refer to page 67)
- Attention: The tools are **without blade**. The blades for the tool need to be ordered separately.
Please refer to page 85 for blade with DRA and DRB geometry.

WARNING NOTICE

The blades of the SNAP5 tools on page 74 and those of the thread tools are **not** interchangeable.

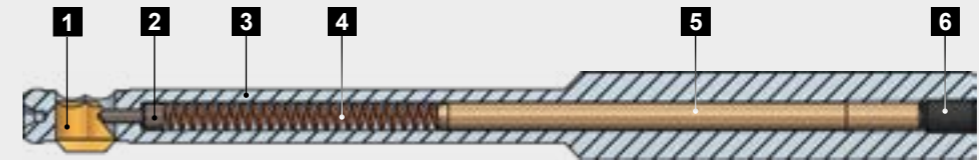

Spare Parts

Pos.	Description	Part No.
1	Blade	see below
2	Control bolt Ø1.5	GH-Q-E-0015
3	Tool body SNAP5/M6 Tool body SNAP5/M8 Tool body SNAP5/M10 Tool body SNAP5/M12 Tool body SNAP5/M14	GH-Q-G-5003 GH-Q-G-5018 GH-Q-G-5010 GH-Q-G-5019 GH-Q-G-5017
4	Spring Ø2.35xØ0.35x30.0	GH-H-F-0019
5	Distance pin Ø2.5x36.0 (M6/M8) Distance pin Ø2.5x50.0 (M10/M12/M14)	GH-Q-E-0049 GH-Q-E-0042
6	Set screw M3x5.0 DIN913 Wrench SW1.5 to Pos. 6	GH-H-S-0127 GH-H-S-2101

Blades DRA Geometry 90° for Standard Materials

Chamfer-Ø ¹	Part No. forward and backward cutting		backward cutting only	
	Coating A	Coating D	Coating A	Coating D
6.5	GH-Q-M-34032	GH-Q-M-34033	GH-Q-M-34532	GH-Q-M-34533
8.5	GH-Q-M-34072	GH-Q-M-34073	GH-Q-M-34572	GH-Q-M-34573
10.5	GH-Q-M-34112	GH-Q-M-34113	GH-Q-M-34612	GH-Q-M-34613
12.5	GH-Q-M-34152	GH-Q-M-34153	GH-Q-M-34652	GH-Q-M-34653
14.5	GH-Q-M-34192	GH-Q-M-34193	GH-Q-M-34692	GH-Q-M-34693

Blades DRB Geometry 90° for very hard and tough Materials

Chamfer-Ø ¹	Part No.	
	forward and backward cutting	backward cutting only
6.5	GH-Q-M-34042	GH-Q-M-34542
8.5	GH-Q-M-34082	GH-Q-M-34582
10.5	GH-Q-M-34122	GH-Q-M-34622
12.5	GH-Q-M-34162	GH-Q-M-34662
14.5	GH-Q-M-34202	GH-Q-M-34702

¹⁾ The indicated dimension is the theoretically possible maximum.

Explanations to coatings (please refer to page 67)

- A: Coating for increased requirements
- D: Coating for aluminium alloys only - available upon customer request only

SNAP Cassette Systems

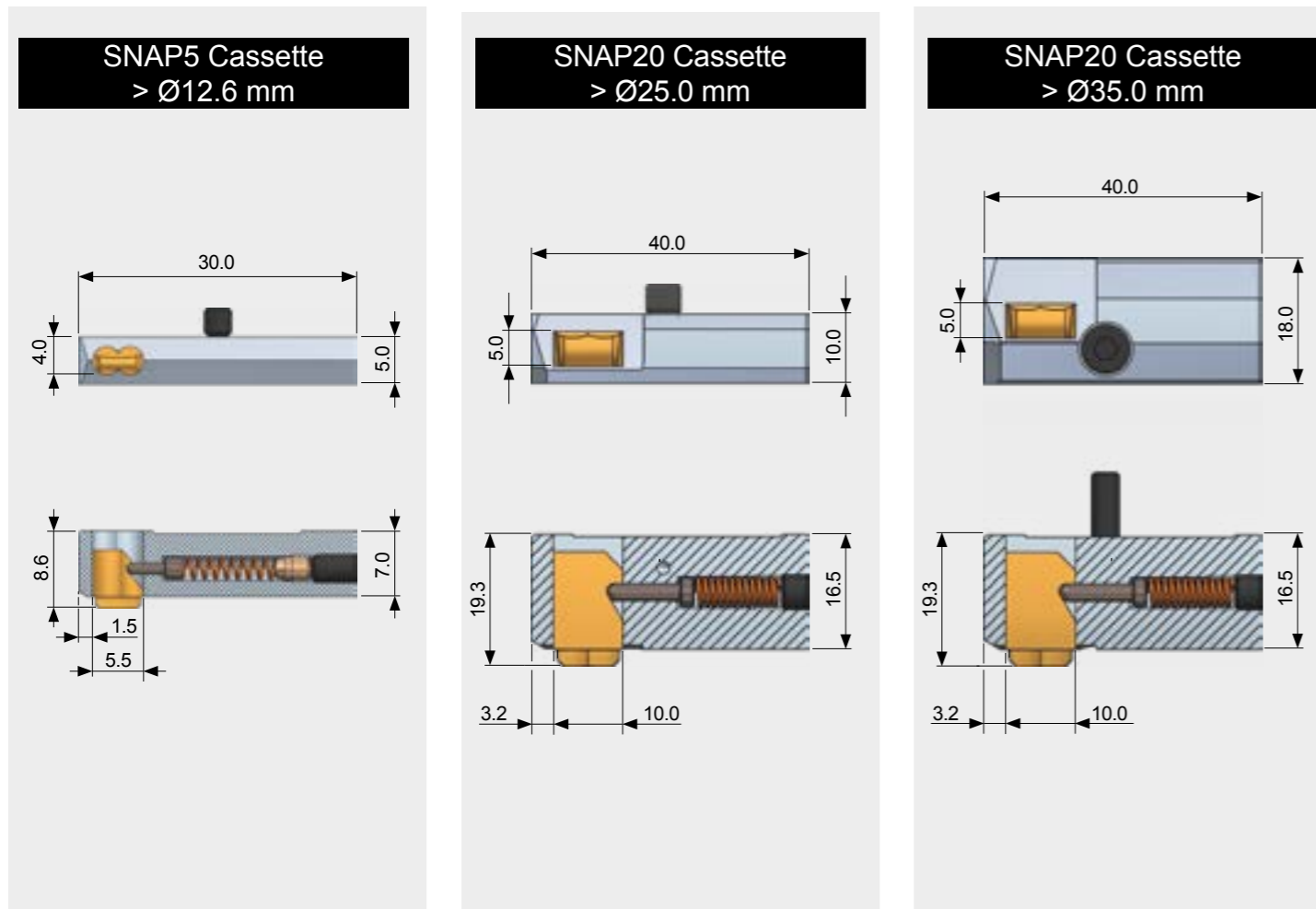

The SNAP Cassette is used for large bore-Ø (larger than Ø35.0 mm). With this cassette the SNAP deburring system is integrated in combi tools and standard tools. The holder can be ordered from us or the customer can use their own, utilizing the information on page 88f.

Tool Table

Type	from Bore-Ø	Dimensions	Cassette complete without Blade Part No.
SNAP5/12.6 Cassette	> Ø12.6 mm	see illustration above	GH-Q-O-1430
SNAP20/25.0 Cassette	> Ø25.0 mm - Ø35.0 mm	see illustration above	GH-Q-O-1130
SNAP20/35.0 Cassette	> Ø35.0 mm	see illustration above	GH-Q-O-1030

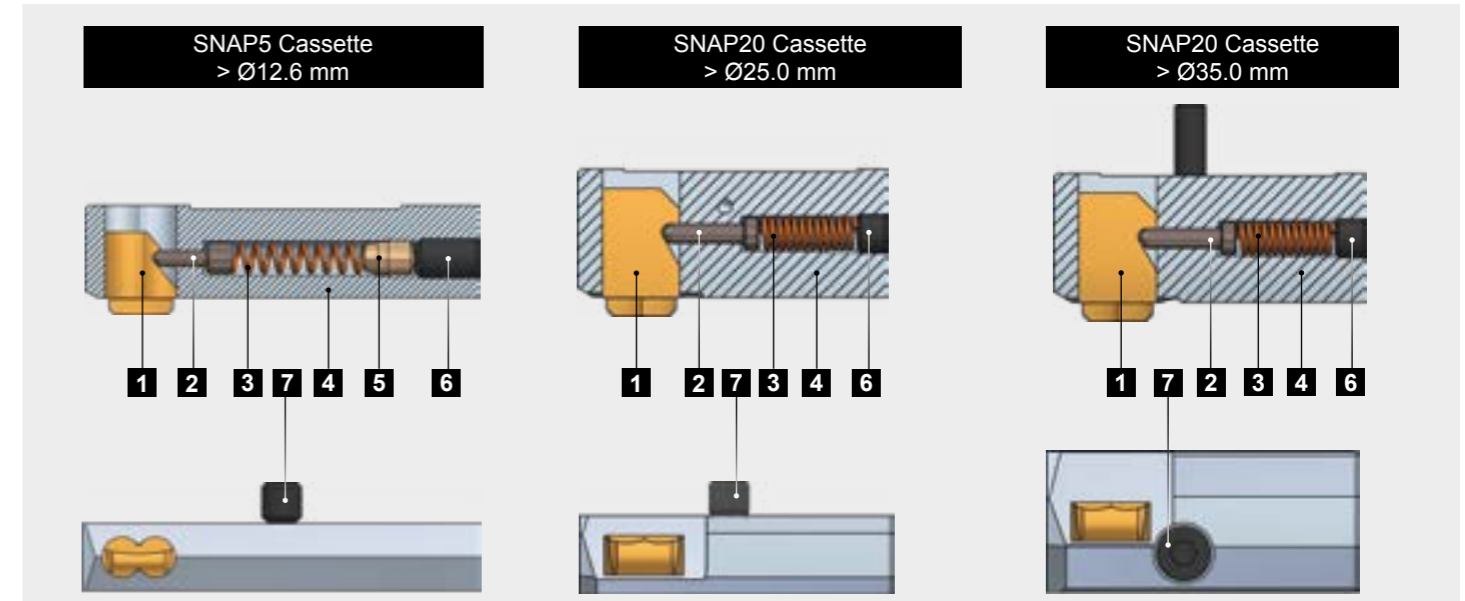

Spare Parts

Pos.	Description	SNAP5/12.6	SNAP20/25	SNAP20/35
1	SNAP blade	see below	see below	see below
2	Control bolt	GH-Q-E-0008	GH-Q-E-0003	GH-Q-E-0003
3	Spring	GH-H-F-0027	GH-H-F-0012	GH-H-F-0012
4	Cassette tool body	GH-Q-G-1382	GH-Q-G-1123	GH-Q-G-1034
5	Distance pin	GH-Q-E-0046	-	-
6	Set screw	GH-H-S-0127	GH-H-S-0120	GH-H-S-0120
7	Set screw	GH-H-S-0355	GH-H-S-0202	GH-H-S-0502
	Wrench to Pos. 7	GH-H-S-2101	GH-H-S-2100	GH-H-S-2100

Cassette Blades with DF Geometry 90°

Chamf. ¹	Bore-Ø	SNAP5 – Part No. forward and backward cutting		backward cutting only	
		Coating A	Coating D	Coating A	Coating D
0.5	20.0-85.0	GH-Q-M-30780*	GH-Q-M-30980	GH-Q-M-31780	GH-Q-M-31980
1.0	20.0-85.0	GH-Q-M-30781*	GH-Q-M-30981	GH-Q-M-31781	GH-Q-M-31981
1.5	20.0-85.0	GH-Q-M-30782*	GH-Q-M-30982	GH-Q-M-31782	GH-Q-M-31982
0.5	90.0-150.0	GH-Q-M-30783*	GH-Q-M-30983	GH-Q-M-31783	GH-Q-M-31983
1.0	90.0-150.0	GH-Q-M-30784*	GH-Q-M-30984	GH-Q-M-31784	GH-Q-M-31984
1.5	90.0-150.0	GH-Q-M-30785*	GH-Q-M-30985	GH-Q-M-31785	GH-Q-M-31985

Chamf. ¹	SNAP20 – Part No. forward and backward cutting		backward cutting only	
	Coating A	Coating T	Coating A	Coating T
0.5	GH-Q-M-01902*	GH-Q-M-01901	GH-Q-M-01922	GH-Q-M-01921
1.0	GH-Q-M-01905*	GH-Q-M-01904	GH-Q-M-01925	GH-Q-M-01924
1.5	GH-Q-M-01908*	GH-Q-M-01907	GH-Q-M-01928	GH-Q-M-01927

^{*)} Standard items / Please enquire about stock or delivery times for all non-standard items.
¹⁾ The indicated dimension is the theoretically possible chamfer capacity / depth maximum.

Explanations to coatings (please refer to page 67)

- T: Coating for normal requirements
- A: Coating for increased requirements
- D: Coating for aluminium alloys only

SNAP5 Cassette
> Ø12.6 mm

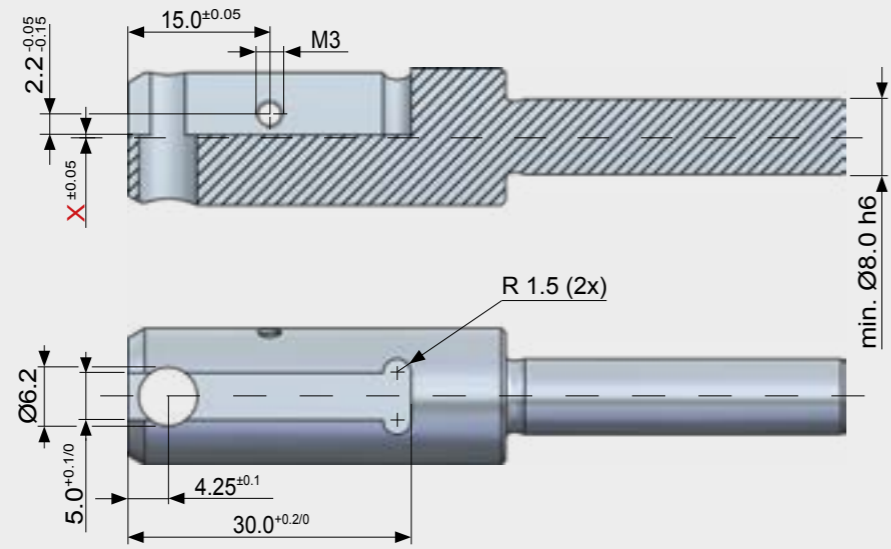

SNAP20 Cassette
> Ø25.0

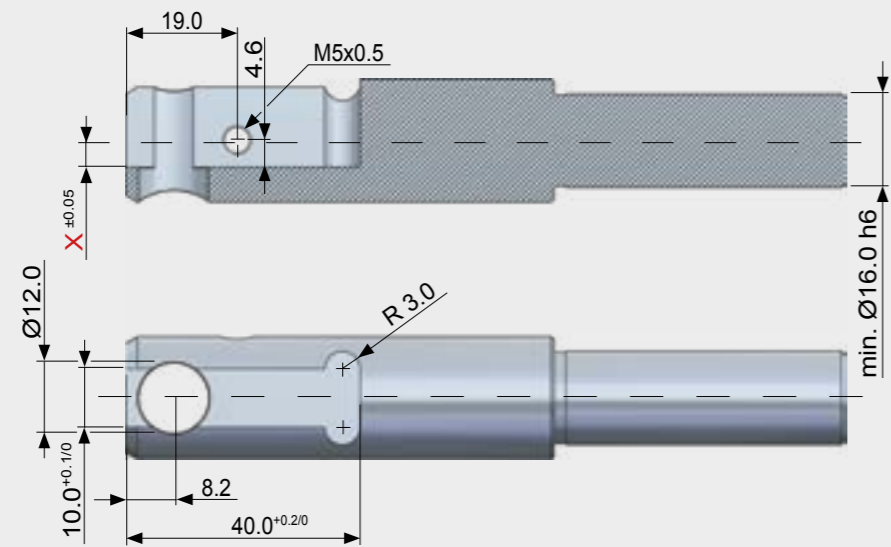

SNAP20 Cassette
> Ø 35.0

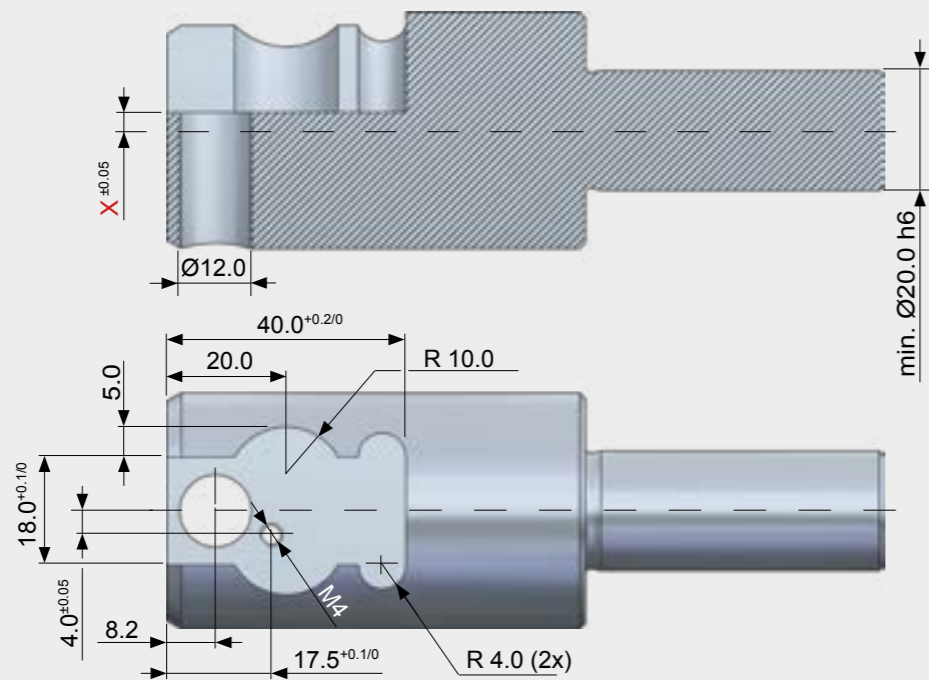

Limiting values

	SNAP5	SNAP20	SNAP20
Bore-Ø	> Ø12.6 mm	> Ø25.0 mm	> Ø35.0 mm
max. ØD	d + 3.0 mm	Ød + 3.0 mm	Ød + 3.0 mm
max. ØD1	Ø - 0.5 mm	Ø - 2.0 mm	Ød - 2.0 mm

Installation Dimensions SNAP Cassettes (continued)

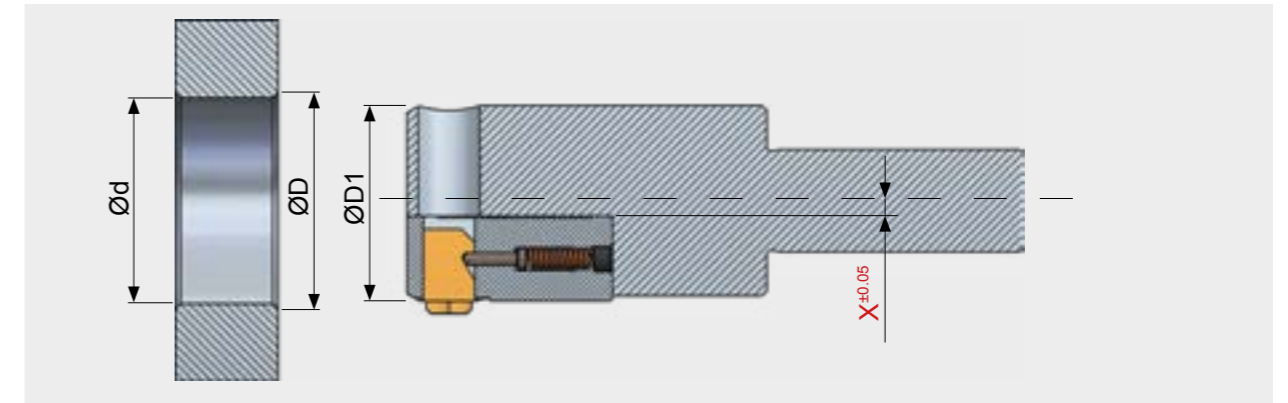

Caption

Bore diameter	Ød
Chamfer diameter	ØD
Tool diameter	ØD1
Locating dimension	X (Must be calculated for every application individually. See formula below.)

Calculation Locating Dimension X for SNAP5 > Ø12.6

$$\text{SNAP5 } > \text{Ø12.6 } X = \text{Ød} / 2.0 - 7.3$$

Calculation Locating Dimension X for SNAP20 > Ø25.0 / Ø35.0

$$\text{SNAP20/25.0 } X = \text{Ød} / 2.0 - 17.0$$

$$\text{SNAP20/35.0 } X = \text{Ød} / 2.0 - 17.0$$

Comparison GS / DF Blade Geometries

Blades with GS Geometry

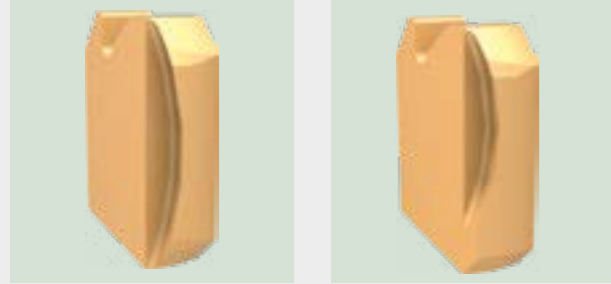

forward and backward cutting

backward cutting only

The blade with the GS geometry is the standard blade. As universal blade it is suitable for most deburring and easy chamfering operations. This blade can also be used in applications where there is slight unevenness on the surface of the component.

Front and back chamfering is achieved by linear feed forward and backward. For back cutting only, a front and back cutting blade can be used also by traversing through the hole in rapid feed without causing damage neither to the front edge of the hole nor to the tool. However, when machining soft materials, it may be necessary to stop the spindle for traversing.

Only when no deburring or chamfering is required or accepted on the front edge of the hole, it is necessary to use the back cutting only blades.

You will find the GS blades in the front section of the catalogue in the blade tables from page 69 onwards.

Blades with DF Geometry

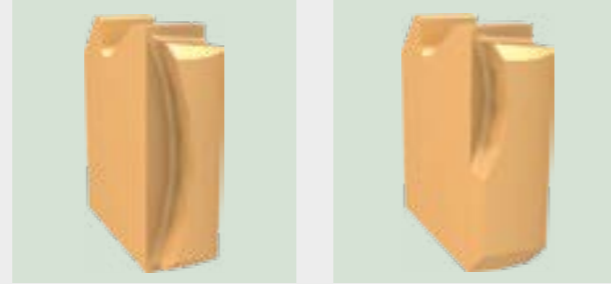

forward and backward cutting

backward cutting only

This blade with DF geometry is mainly used when a defined, toleranced or consistent chamfer size is required. It is also recommended for use on hard materials or on materials with excessive burr formation.

This blade type is responsive to the condition of the machine such as clamping of workpiece and tool as well as a stable machine spindle etc.

If no front chamfer is required, a **back cutting only blade has to be used.**

The upper values of the feed rate for blades with DF geometry listed on page 94 should not be exceeded as blade breakage may result.

The range of DF blades is listed on page 91f.

Blade Range with DF Geometry

SNAP8 Blades with DF Geometry 90°

Chamfer-Ø ¹	Part No. forward and backward cutting		backward cutting only	
	Coating T	Coating A	Coating T	Coating A
8.5	GH-Q-M-03120	GH-Q-M-03220	GH-Q-M-05120	GH-Q-M-05220
9.0	GH-Q-M-03121	GH-Q-M-03221	GH-Q-M-05121	GH-Q-M-05221
9.5	GH-Q-M-03122	GH-Q-M-03222	GH-Q-M-05122	GH-Q-M-05222
10.0	GH-Q-M-03123	GH-Q-M-03223	GH-Q-M-05123	GH-Q-M-05223
10.5	GH-Q-M-03124	GH-Q-M-03224	GH-Q-M-05124	GH-Q-M-05224
11.0	GH-Q-M-03125	GH-Q-M-03225	GH-Q-M-05125	GH-Q-M-05225
11.5	GH-Q-M-03126	GH-Q-M-03226	GH-Q-M-05126	GH-Q-M-05226
12.0	GH-Q-M-03127	GH-Q-M-03227	GH-Q-M-05127	GH-Q-M-05227
12.5	GH-Q-M-03128	GH-Q-M-03228	GH-Q-M-05128	GH-Q-M-05228
13.0	GH-Q-M-03129	GH-Q-M-03229	GH-Q-M-05129	GH-Q-M-05229
13.5	GH-Q-M-03130	GH-Q-M-03230	GH-Q-M-05130	GH-Q-M-05230

SNAP12 Blades with DF Geometry 90°

Chamfer-Ø ¹	Part No. forward and backward cutting		backward cutting only	
	Coating T	Coating A	Coating T	Coating A
12.5	GH-Q-M-03140	GH-Q-M-03240	GH-Q-M-05140	GH-Q-M-05240
13.0	GH-Q-M-03141	GH-Q-M-03241	GH-Q-M-05141	GH-Q-M-05241
13.5	GH-Q-M-03142	GH-Q-M-03242	GH-Q-M-05142	GH-Q-M-05242
14.0	GH-Q-M-03143	GH-Q-M-03243	GH-Q-M-05143	GH-Q-M-05243
14.5	GH-Q-M-03144	GH-Q-M-03244	GH-Q-M-05144	GH-Q-M-05244
15.0	GH-Q-M-03145	GH-Q-M-03245	GH-Q-M-05145	GH-Q-M-05245
15.5	GH-Q-M-03146	GH-Q-M-03246	GH-Q-M-05146	GH-Q-M-05246
16.0	GH-Q-M-03147	GH-Q-M-03247	GH-Q-M-05147	GH-Q-M-05247
16.5	GH-Q-M-03148	GH-Q-M-03248	GH-Q-M-05148	GH-Q-M-05248
17.0	GH-Q-M-03149	GH-Q-M-03249	GH-Q-M-05149	GH-Q-M-05249
17.5	GH-Q-M-03150	GH-Q-M-03250	GH-Q-M-05150	GH-Q-M-05250
18.0	GH-Q-M-03151	GH-Q-M-03251	GH-Q-M-05151	GH-Q-M-05251
18.5	GH-Q-M-03152	GH-Q-M-03252	GH-Q-M-05152	GH-Q-M-05252
19.0	GH-Q-M-03153	GH-Q-M-03253	GH-Q-M-05153	GH-Q-M-05253
19.5	GH-Q-M-03154	GH-Q-M-03254	GH-Q-M-05154	GH-Q-M-05254
20.0	GH-Q-M-03155	GH-Q-M-03255	GH-Q-M-05155	GH-Q-M-05255
20.5	GH-Q-M-03156	GH-Q-M-03256	GH-Q-M-05156	GH-Q-M-05256
21.0	GH-Q-M-03157	GH-Q-M-03257	GH-Q-M-05157	GH-Q-M-05257
21.5	GH-Q-M-03158	GH-Q-M-03258	GH-Q-M-05158	GH-Q-M-05258
22.0	GH-Q-M-03159	GH-Q-M-03259	GH-Q-M-05159	GH-Q-M-05259

¹⁾ The indicated dimension is the theoretically possible chamfer capacity / depth maximum.

Chamfer-Ø ¹	Part No. forward and backward cutting		back cutting only	
	Coating T	Coating A	Coating T	Coating A
21.0	GH-Q-M-03170	GH-Q-M-03270	GH-Q-M-05170	GH-Q-M-05270
22.0	GH-Q-M-03171	GH-Q-M-03271	GH-Q-M-05171	GH-Q-M-05271
23.0	GH-Q-M-03172	GH-Q-M-03272	GH-Q-M-05172	GH-Q-M-05272
24.0	GH-Q-M-03173	GH-Q-M-03273	GH-Q-M-05173	GH-Q-M-05273
25.0	GH-Q-M-03174	GH-Q-M-03274	GH-Q-M-05174	GH-Q-M-05274
26.0	GH-Q-M-03175	GH-Q-M-03275	GH-Q-M-05175	GH-Q-M-05275
27.0	GH-Q-M-03176	GH-Q-M-03276	GH-Q-M-05176	GH-Q-M-05276
28.0	GH-Q-M-03177	GH-Q-M-03277	GH-Q-M-05177	GH-Q-M-05277
29.0	GH-Q-M-03178	GH-Q-M-03278	GH-Q-M-05178	GH-Q-M-05278
30.0	GH-Q-M-03179	GH-Q-M-03279	GH-Q-M-05179	GH-Q-M-05279
31.0	GH-Q-M-03180	GH-Q-M-03280	GH-Q-M-05180	GH-Q-M-05280
32.0	GH-Q-M-03181	GH-Q-M-03281	GH-Q-M-05181	GH-Q-M-05281
33.0	GH-Q-M-03182	GH-Q-M-03282	GH-Q-M-05182	GH-Q-M-05282
34.0	GH-Q-M-03183	GH-Q-M-03283	GH-Q-M-05183	GH-Q-M-05283
35.0	GH-Q-M-03184	GH-Q-M-03284	GH-Q-M-05184	GH-Q-M-05284
36.0	GH-Q-M-03185	GH-Q-M-03285	GH-Q-M-05185	GH-Q-M-05285
37.0	GH-Q-M-03186	GH-Q-M-03286	GH-Q-M-05186	GH-Q-M-05286
38.0	GH-Q-M-03187	GH-Q-M-03287	GH-Q-M-05187	GH-Q-M-05287

¹⁾ The indicated dimension is the theoretically possible chamfer capacity / depth maximum.

Explanations to coatings (please refer to page 67)

- T: Coating for normal requirements
- A: Coating for increased requirements

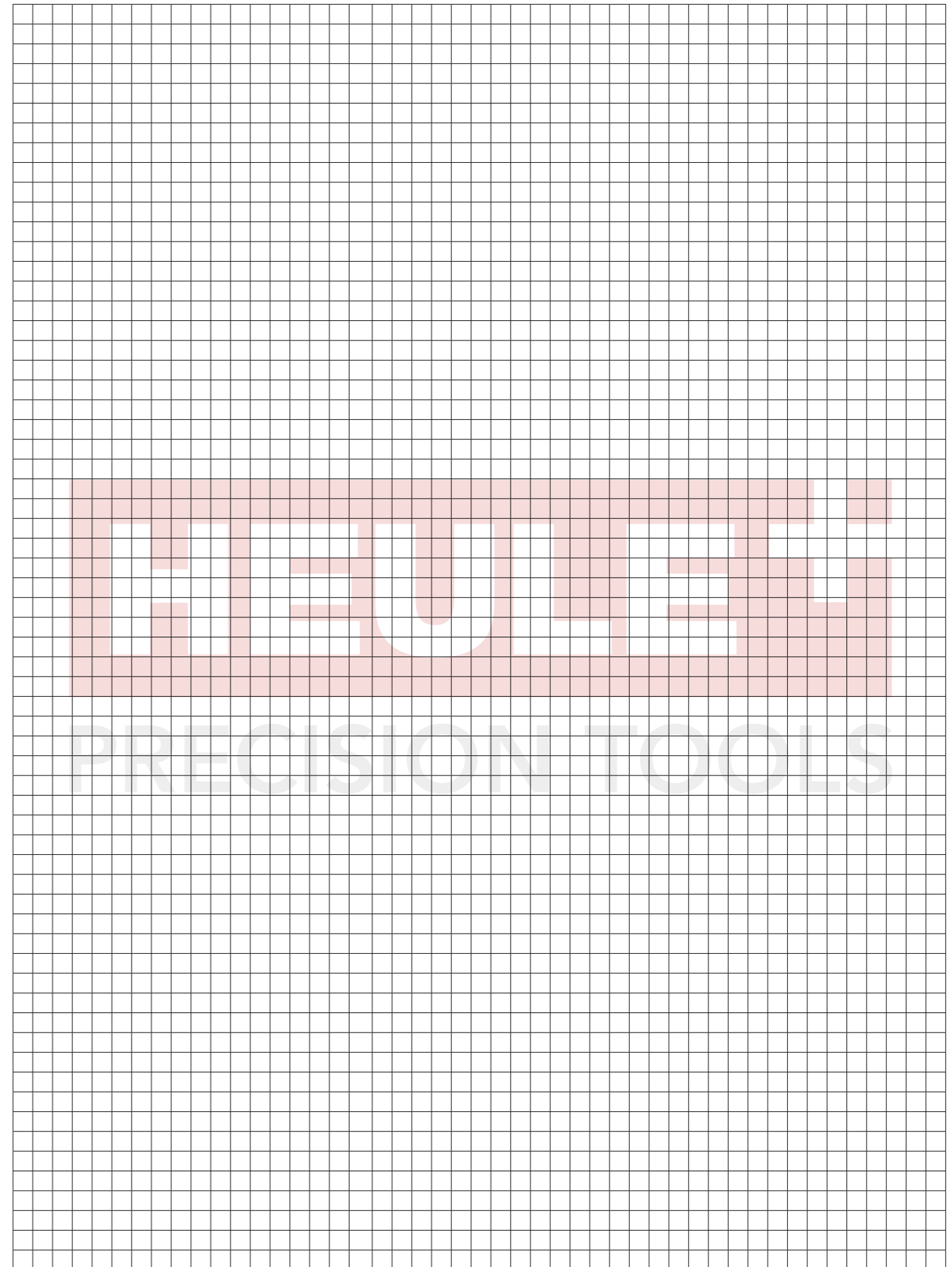

Technical Data and Settings

Cutting Data SNAP¹

Material	Condition	Tensile strength (N/mm ²)	Hardness HB	SNAP 2/3/4		SNAP 5/8/12/20 GS	
				Cutting speed (m/min)	Feed (mm/rev)	Cutting speed (m/min)	Feed (mm/rev)
Unalloyed steel		<500	<150	40-70	0.02-0.1	40-70	0.1-0.3
Cast steel		500 - 850	150 - 250	40-70	0.02-0.1	40-70	0.1-0.3
Grey cast iron		<500	<150	50-90	0.02-0.1	50-90	0.1-0.3
Ductile cast iron		300 - 800	90 - 240	40-70	0.02-0.1	40-70	0.1-0.3
Low alloy steel	annealed	<850	<250	40-70	0.02-0.1	40-70	0.1-0.3
	tempered	850 - 1000	250 - 300	30-50	0.02-0.1	30-50	0.1-0.2
	tempered	>1000 - 1200	>300 - 350	30-50	0.02-0.1	30-50	0.1-0.2
High alloy steel	annealed	<850	<250	20-50	0.02-0.1	20-50	0.1-0.2
	tempered	850 - 1100	250 - 320	15-30	0.02-0.1	15-30	0.1-0.15
Stainless steel	ferritic	450 - 650	130 - 190	15-30	0.02-0.05	15-30	0.05-0.15
	austenitic	650 - 900	190 - 270	10-20	0.02-0.05	10-20	0.05-0.15
	martensitic	500 - 700	150 - 200	15-30	0.02-0.05	15-30	0.02-0.15
Special alloy (Inconel, titanium)		<1200	<350	10-20	0.02-0.05	10-20	0.02-0.1
Wrought or cast aluminium alloys				70-120	0.05-0.15	70-120	0.1-0.3
Copper alloy	Brass			60-90	0.02-0.05	60-90	0.05-0.15
	Bronze short-chipping			30-50	0.02-0.05	30-50	0.05-0.15
	Bronze long-chipping			20-30	0.02-0.05	20-30	0.05-0.15

Material	Condition	Tensile strength (N/mm ²)	Hardness HB	SNAP 5 DF		SNAP 5 DR	
				Cutting speed (m/min)	Feed (mm/rev)	Cutting speed (m/min)	Feed (mm/rev)
Unalloyed steel		<500	<150	40-70	0.02-0.08	40-70	0.05-0.1
Cast steel		500 - 850	150 - 250	40-70	0.02-0.08	40-70	0.05-0.1
Grey cast iron		<500	<150	50-90	0.02-0.08	50-90	0.05-0.1
Ductile cast iron		300 - 800	90 - 240	40-70	0.02-0.08	40-70	0.05-0.1
Low alloy steel	annealed	<850	<250	40-70	0.02-0.08	40-70	0.05-0.1
	tempered	850 - 1000	250 - 300	30-50	0.02-0.08	30-50	0.05-0.1
	tempered	>1000 - 1200	>300 - 350	20-40	0.02-0.06	20-40	0.05-0.06
High alloy steel	annealed	<850	<250	20-50	0.02-0.08	20-50	0.05-0.08
	tempered	850 - 1100	250 - 320	15-30	0.02-0.06	15-30	0.02-0.06
Stainless steel	ferritic	450 - 650	130 - 190	15-30	0.02-0.08	15-30	0.05-0.1
	austenitic	650 - 900	190 - 270	10-20	0.02-0.06	10-20	0.05-0.08
	martensitic	500 - 700	150 - 200	15-30	0.02-0.06	15-30	0.02-0.06
Special alloy (Inconel, titanium)		<1200	<350	10-20	0.02-0.06	10-20	0.02-0.06
Wrought or cast aluminium alloys				70-120	0.02-0.1	70-120	0.05-0.2
Copper alloy	Brass			60-90	0.02-0.08	60-90	0.05-0.1
	Bronze short-chipping			30-50	0.02-0.06	30-50	0.05-0.1
	Bronze long-chipping			20-30	0.02-0.06	20-30	0.05-0.1

¹⁾ Please pay attention to the WARNING NOTICE on the bottom of page 95.

Programming Information

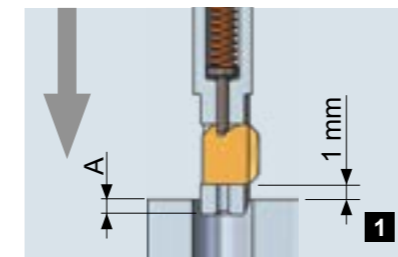

It is not necessary at all to change the sense of rotation or to stop the spindle during the whole process. First, rapid traverse of the tool blade above the top material surface of bore or burr.

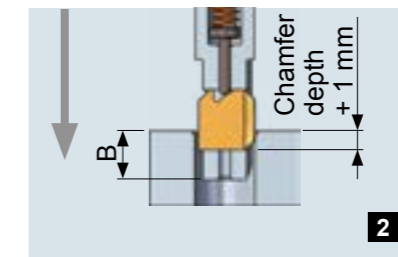

To generate the front chamfer continue in working feed until the blade is completely retracted into the tool.

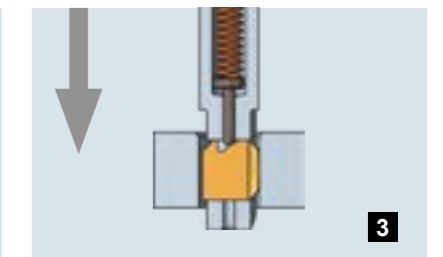

Rapid traverse through the hole. The surface of the hole cannot be damaged.

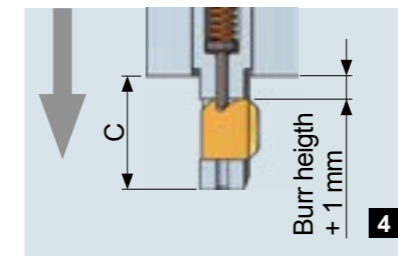

Go 1.0 mm beyond the existing burr in order to reach a safe initial position for the back chamfering.

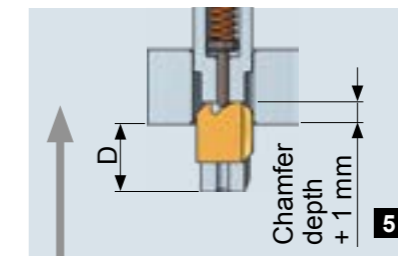

In back working feed the backward chamfering is executed. Proceed with the blade 1.0 mm farther than the planned chamfering depth.

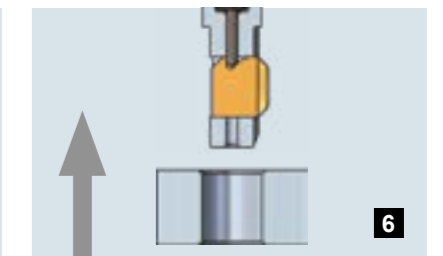

Then exit in rapid traverse to the next bore.

Dimension Table to Programming Information

Tool	A	B	C	D
SNAP2	1.0	3.0	5.0	3.0
SNAP3	1.0	3.5	6.0	3.5
SNAP4	1.0	4.0	7.0	4.0
SNAP5	2.0	6.0	9.5	6.0
SNAP8	3.0	8.0	13.0	8.0
SNAP12	5.5	10.5	15.5	10.5
SNAP20	6.0	12.0	18.0	12.0

WARNING NOTICE - Cutting Data SNAP

All listed cutting data are standard values only! The cutting values depend on the amount of slope of the uneven bore edge. (i.e. high slope ► low cutting value). The feed also depends on the sloping ratio. In case of hard to machine materials or uneven bore edges, we recommend to apply cutting speeds that are at the lower end of the range for uneven bore edges.

Blades with GS geometry

In general, the chamfer size is defined by the selected blade (blade length). Each blade produces a defined chamfer size.

The theoretically possible chamfer size maximum can be taken from the column "chamfer-Ø max. D" in the blade tables.

Blades with DF geometry

For SNAP blades with DF or DR geometry (thread tools), the chamfer capacity is defined exclusively by the chamfer-Ø of the blade table. This means that neither the feed rate nor an adjustment of the blade force changes the chamfer size.

For choosing the right feed rate please refer to the cutting data chart on page 94.

The blade force has to be sufficient to enable the blade to extend outwards in the event of swarf ingress.

Setting the Blade Force



The blade force can be adjusted by the set screw in the rear of the shank. The blade force has to be sufficient to extend the blade to fully after passing the back end of the bore. This ensures that the blade can work with the necessary cutting performance. The tougher the material the tougher the spring should be set. **The blade force however does not influence the chamfer size.** Working with the correct blade pressure increases the blade life and improves the chamfer quality. An extremely tough

material requires a high spring force. For this purpose, the springs can be exchanged (SNAP5: GH-H-F-0041, SNAP8 und SNAP12: GH-H-F-0011).

Turning the set screw clockwise increases the blade force (tough steel, Inconel, titanium). Turning the set screw anti-clockwise reduces the blade force (aluminium).

Adjustment Details Blade Force

Tool	Thread size	Screw-in depth (max.)	Number of revolutions
SNAP2/3/4	M3	6.0 mm	approx. 12 rev.
SNAP5	M3	6.0 mm	approx. 12 rev.
SNAP5 (Thread tools)	M3	14.0 mm	approx. 28 rev.
SNAP8	M5	11.0 mm	approx. 13 rev.
SNAP12	M5	11.0 mm	approx. 13 rev.
SNAP20	M5	11.0 mm	approx. 13 rev.



Tool with SNAP2 blade mounted

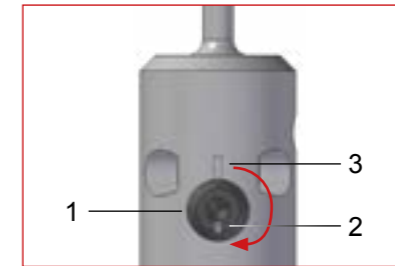

Turn excenter (1) by 180° until the groove of the excenter (2) is 180° opposite to the groove of the tool body (3).

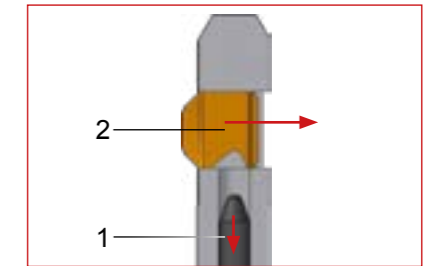

By the movement of the excenter, the control bolt (1) is pulled back out of the blade recess. Then the blade (2) can be easily pushed out in the indicated direction.

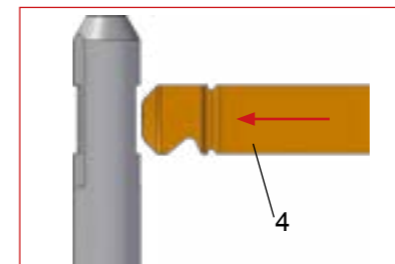

When mounting a new blade with integrated assembly aid (4), please make sure to insert the blade with the cutting geometry first into the blade housing.

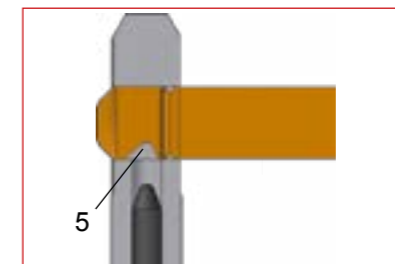

Push the blade so far that the control recess of the blade (5) is over the bolt cross bore. As an optical aid, the cutting geometry should be visible to the full extent on the other side of the blade housing.



Turn back the excenter by 180° until the groove of the excenter is aligned with the groove in the tool body.

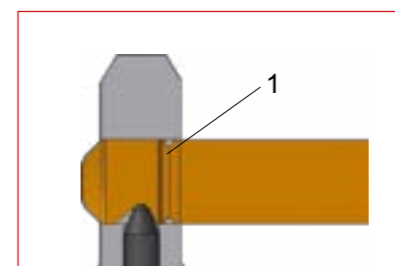

By turning back the excenter, the control bolt moves forward into the control recess of the blade.

1) Predetermined breaking point

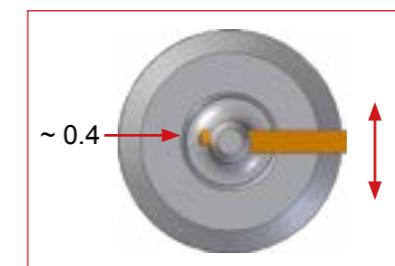

Remove assembly aid of the blade by pushing back the blade by approx. 0.4mm until the predetermined breaking point is in line with the edge of the blade window. Then break off assembly aid by using thumb and index.



The blade moves back to the starting point as soon as it is released.

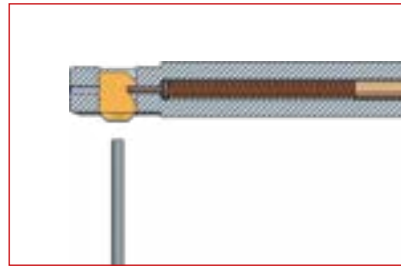

Tool SNAP12 with assembled blade

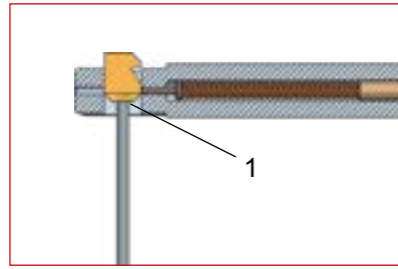

The SNAP blade can be pushed through the tool with an edgeless object. Put the aid on at the blade head (1).

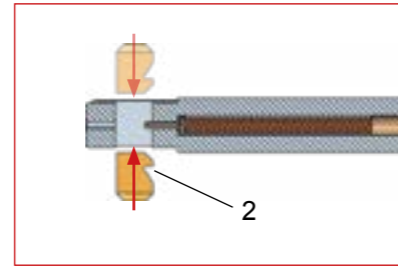

The deburring blade is pushed with its back first into the blade window of the tool until it engages. Please make sure that it is aligned with the recess (2) in the direction of the tool shank. The blade can be inserted into the tool from both sides.

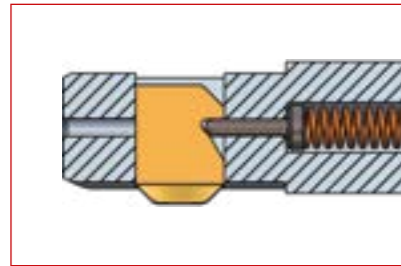

The control bolt has "snapped" into the blade recess. The tool is now ready for operation.

Spare Parts

The following tables comprise all blade housings, tool bodies and control bolts. For all other parts, please refer to the tables under "Product Selection" on pages 69 to 87.

Blade housing				
Tool Ref.	Tool-Ø D1	Part No.		
		Working length NL 10.0 mm	Working length NL 20.0 mm	Working length NL 30.0 mm
SNAP2/2.0/...	1.95	GH-Q-N-0001	GH-Q-N-0061	-
SNAP2/2.1/...	2.05	GH-Q-N-0002	GH-Q-N-0062	-
SNAP2/2.2/...	2.15	GH-Q-N-0003	GH-Q-N-0063	-
SNAP2/2.3/...	2.25	GH-Q-N-0004	GH-Q-N-0064	-
SNAP2/2.4/...	2.35	GH-Q-N-0005	GH-Q-N-0065	-
SNAP2/2.5/...	2.45	GH-Q-N-0006	GH-Q-N-0066	-
SNAP2/2.6/...	2.55	GH-Q-N-0007	GH-Q-N-0067	-
SNAP2/2.7/...	2.65	GH-Q-N-0008	GH-Q-N-0068	-
SNAP2/2.8/...	2.75	GH-Q-N-0009	GH-Q-N-0069	-
SNAP2/2.9/...	2.85	GH-Q-N-0010	GH-Q-N-0070	-
SNAP3/3.0/...	2.9	GH-Q-N-0021	GH-Q-N-0081	GH-Q-N-0141
SNAP3/3.1/...	3.0	GH-Q-N-0022	GH-Q-N-0082	GH-Q-N-0142
SNAP3/3.2/...	3.1	GH-Q-N-0023	GH-Q-N-0083	GH-Q-N-0143
SNAP3/3.3/...	3.2	GH-Q-N-0024	GH-Q-N-0084	GH-Q-N-0144
SNAP3/3.4/...	3.3	GH-Q-N-0025	GH-Q-N-0085	GH-Q-N-0145
SNAP3/3.5/...	3.4	GH-Q-N-0026	GH-Q-N-0086	GH-Q-N-0146
SNAP3/3.6/...	3.5	GH-Q-N-0027	GH-Q-N-0087	GH-Q-N-0147
SNAP3/3.7/...	3.6	GH-Q-N-0028	GH-Q-N-0088	GH-Q-N-0148
SNAP3/3.8/...	3.7	GH-Q-N-0029	GH-Q-N-0089	GH-Q-N-0149
SNAP3/3.9/...	3.8	GH-Q-N-0030	GH-Q-N-0090	GH-Q-N-0150
SNAP4/4.0/...	3.9	GH-Q-N-0041	GH-Q-N-0101	GH-Q-N-0161
SNAP4/4.1/...	4.0	GH-Q-N-0042	GH-Q-N-0102	GH-Q-N-0162
SNAP4/4.2/...	4.1	GH-Q-N-0043	GH-Q-N-0103	GH-Q-N-0163
SNAP4/4.3/...	4.2	GH-Q-N-0044	GH-Q-N-0104	GH-Q-N-0164
SNAP4/4.4/...	4.3	GH-Q-N-0045	GH-Q-N-0105	GH-Q-N-0165
SNAP4/4.5/...	4.4	GH-Q-N-0046	GH-Q-N-0106	GH-Q-N-0166
SNAP4/4.6/...	4.5	GH-Q-N-0047	GH-Q-N-0107	GH-Q-N-0167
SNAP4/4.7/...	4.6	GH-Q-N-0048	GH-Q-N-0108	GH-Q-N-0168
SNAP4/4.8/...	4.7	GH-Q-N-0049	GH-Q-N-0109	GH-Q-N-0169
SNAP4/4.9/...	4.8	GH-Q-N-0050	GH-Q-N-0110	GH-Q-N-0170
SNAP4/5.0/...	4.9	GH-Q-N-0051	GH-Q-N-0111	GH-Q-N-0171

Order Example:
SNAP3/3.0/20 = Blade housing GH-Q-N-0081 = NL 20.0 mm

Spare Parts (continued)

Tool Body		
Tool Reference	Tool-Ø D1	Part No.
SNAP5		
SNAP5/5.0	4.9	GH-Q-G-1271
SNAP5/5.5	5.4	GH-Q-G-1272
SNAP5/6.0	5.9	GH-Q-G-1273
SNAP5/6.5	6.4	GH-Q-G-1274
SNAP5/7.0	6.9	GH-Q-G-1275
SNAP5/7.5	7.4	GH-Q-G-1276
SNAP5/8.0	7.8	GH-Q-G-1277
SNAP5/8.5	8.3	GH-Q-G-1389
SNAP5/9.0	8.8	GH-Q-G-1384
SNAP5/9.5	9.3	GH-Q-G-1485
SNAP5/10.0	9.8	GH-Q-G-1486
SNAP8		
SNAP8/8.0	7.8	GH-Q-G-0220
SNAP8/8.5	8.3	GH-Q-G-0221
SNAP8/9.0	8.8	GH-Q-G-0222
SNAP8/9.5	9.3	GH-Q-G-0223
SNAP8/10.0	9.8	GH-Q-G-0224
SNAP8/10.5	10.3	GH-Q-G-0225
SNAP8/11.0	10.8	GH-Q-G-0226
SNAP8/11.5	11.3	GH-Q-G-0227
SNAP8/12.0	11.8	GH-Q-G-0228
SNAP12		
SNAP12/12.0	11.8	GH-Q-G-0240
SNAP12/12.5	12.3	GH-Q-G-0241
SNAP12/13.0	12.8	GH-Q-G-0242
SNAP12/13.5	13.3	GH-Q-G-0243
SNAP12/14.0	13.8	GH-Q-G-0244
SNAP12/14.5	14.3	GH-Q-G-0245
SNAP12/15.0	14.8	GH-Q-G-0246
SNAP12/15.5	15.3	GH-Q-G-0247
SNAP12/16.0	15.8	GH-Q-G-0248
SNAP12/16.5	16.3	GH-Q-G-0249
SNAP12/17.0	16.8	GH-Q-G-0250
SNAP12/17.5	17.3	GH-Q-G-0251
SNAP12/18.0	17.8	GH-Q-G-0252
SNAP12/18.5	18.3	GH-Q-G-0253
SNAP12/19.0	18.8	GH-Q-G-0254
SNAP12/19.5	19.3	GH-Q-G-0255
SNAP12/20.0	19.8	GH-Q-G-0256
SNAP20		
SNAP20/20.0	19.8	GH-Q-G-0270
SNAP20/21.0	20.8	GH-Q-G-0271
SNAP20/22.0	21.8	GH-Q-G-0272
SNAP20/23.0	22.8	GH-Q-G-0273
SNAP20/24.0	23.8	GH-Q-G-0274
SNAP20/25.0	24.8	GH-Q-G-0275
SNAP20/26.0	25.8	GH-Q-G-0276

Spare Parts (continued)

Tool Body (continued)		
Tool Reference	Tool-Ø D1	Part No.
SNAP20/27.0	26.8	GH-Q-G-0277
SNAP20/28.0	27.8	GH-Q-G-0278
SNAP20/29.0	28.8	GH-Q-G-0279
SNAP20/30.0	29.8	GH-Q-G-0280
SNAP20/31.0	30.8	GH-Q-G-0281
SNAP20/32.0	31.8	GH-Q-G-0282
SNAP20/33.0	32.8	GH-Q-G-0283
SNAP20/34.0	33.8	GH-Q-G-0284
SNAP20/35.0	34.8	GH-Q-G-0285
Thread Tool		
SNAP2/M2.5/10, SNAP2/M2.5/20	2.0	GH-Q-N-0015, GH-Q-N-0075
SNAP2/M3/10, SNAP2/M3/20	2.45	GH-Q-N-0016, GH-Q-N-0076
SNAP3/M4/10, SNAP3/M4/20, SNAP3/M4/30	3.2	GH-Q-N-0035, GH-Q-N-0095, GH-Q-N-0155
SNAP4/M5/10, SNAP4/M5/20, SNAP4/M5/30	4.1	GH-Q-N-0055, GH-Q-N-0115, GH-Q-N-0175
SNAP5/M6	4.9	GH-Q-G-5003
SNAP5/M8	6.7	GH-Q-G-5018
SNAP5/M10	8.3	GH-Q-G-5010
SNAP5/M12	10.0	GH-Q-G-5019
SNAP5/M14	11.8	GH-Q-G-5017

Control Bolt				
Tool Reference	Part No.			
	other Working length	Working length 10.0 mm	Working length 20.0 mm	Working length 30.0 mm
SNAP2	-	GH-Q-E-0236	GH-Q-E-0237	
SNAP3	-	GH-Q-E-0236	GH-Q-E-0237	GH-Q-E-0238
SNAP4	-	GH-Q-E-0236	GH-Q-E-0237	GH-Q-E-0238
SNAP5	GH-Q-E-0008	-	-	-
SNAP8	GH-Q-E-0002	-	-	-
SNAP12	GH-Q-E-0002	-	-	-
SNAP 20	GH-Q-E-0003	-	-	-

SNAP Thread Tool				
Tool Reference	Part No.	Working length 10.0 mm	Working length 20.0 mm	Working length 30.0 mm
SNAP2/M2.5	-	GH-Q-E-0254	GH-Q-E-0256	-
SNAP2/M3	-	GH-Q-E-0236	GH-Q-E-0237	-
SNAP3/M4	-	GH-Q-E-0236	GH-Q-E-0237	GH-Q-E-0238
SNAP4/M5	-	GH-Q-E-0236	GH-Q-E-0237	GH-Q-E-0238
SNAP5/M6	GH-Q-E-0015	-	-	-
SNAP5/M8	GH-Q-E-0015	-	-	-
SNAP5/M10	GH-Q-E-0015	-	-	-
SNAP5/M12	GH-Q-E-0015	-	-	-
SNAP5/M14	GH-Q-E-0015	-	-	-

Cassette Tool				
Tool Reference	Part No.	Working length 10.0 mm	Working length 20.0 mm	Working length 30.0 mm
SNAP5/12.6	GH-Q-E-0008	-	-	-
SNAP20/25	GH-Q-E-0003	-	-	-
SNAP20/35	GH-Q-E-0003	-	-	-

Blade Dimensions

Dimension Table

SNAP2, Geometry GS 90°, forward and backward cutting				
Chamfer-Ø	A	C	X	Y
2.4	1.92	0.525	1.0	2.0
2.6	2.03	0.625	1.0	2.0
2.8	2.12	0.625	1.0	2.0
3.0	2.32	0.625	1.0	2.0
3.2	2.52	0.625	1.0	2.0
3.4	2.72	0.625	1.0	2.0

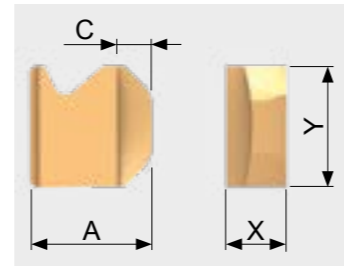

SNAP3, Geometry GS 90°, forward and backward cutting				
Chamfer-Ø	A	C	X	Y
3.3	2.84	0.55	1.0	3.0
3.6	2.84	0.7	1.0	3.0
3.9	2.84	0.85	1.0	3.0
4.2	3.04	0.9	1.0	3.0
4.5	3.04	0.9	1.0	3.0
4.8	3.04	0.9	1.0	3.0

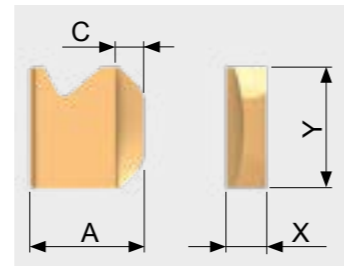

SNAP4, Geometry GS, forward and backward cutting				
Chamfer-Ø	A	C	X	Y
4.4	3.84	0.65	1.0	4.0
4.8	3.84	0.85	1.0	4.0
5.2	3.84	1.05	1.0	4.0
5.6	3.94	1.2	1.0	4.0
6.0	4.35	1.2	1.0	4.0
6.4	4.75	1.2	1.0	4.0

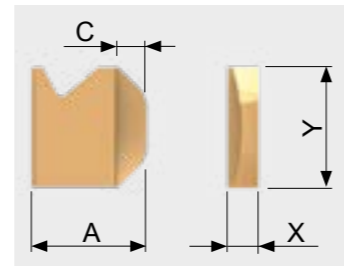

SNAP5, Geometry GS, forward and backward cutting				
Chamfer-Ø	A	C	X	Y
5.5	4.4	1.0	3.0	5.5
6.0	4.65	1.2	3.0	5.5
6.5	4.8	1.4	3.0	5.5
7.0	4.85	1.6	3.0	5.5
7.5	5.2	1.7	3.0	5.5
8.0	5.7	1.8	3.0	5.5
8.5	5.8	1.8	3.0	5.5
9.0	6.3	1.8	3.0	5.5
9.5	6.8	1.8	3.0	5.5
10.0	7.3	1.8	3.0	5.5

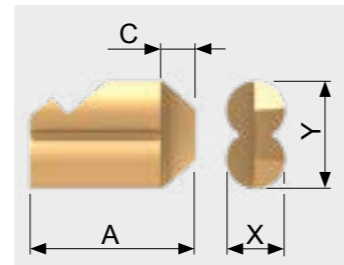

SNAP8, Geometry GS, forward and backward cutting				
Chamfer-Ø	A	C	X	Y
8.5	7.4	1.2	2.0	8.0
9.0	7.5	1.4	2.0	8.0
9.5	7.9	1.6	2.0	8.0
10.0	8.0	1.6	2.0	8.0
10.5	8.4	1.6	2.0	8.0
11.0	8.5	1.8	2.0	8.0
11.5	8.9	1.8	2.0	8.0
12.0	9.3	1.8	2.0	8.0
12.5	9.7	1.8	2.0	8.0
13.0	10.1	1.8	2.0	8.0
13.5	10.4	1.8	2.0	8.0

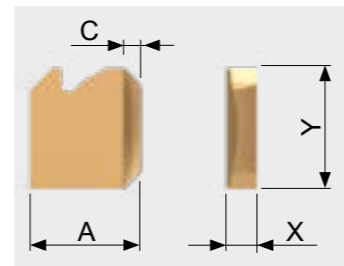

Dimension Table (continued)

SNAP12, Geometry GS 90°, forward and backward cutting				
Chamfer-Ø	A	C	X	Y
12.5	10.45	1.8	3.0	8.0
13.0	10.65	1.8	3.0	8.0
13.5	10.95	1.8	3.0	8.0
14.0	11.45	1.8	3.0	8.0
14.5	11.95	1.8	3.0	8.0
15.0	12.45	1.8	3.0	8.0
15.5	12.75	1.8	3.0	8.0
16.0	12.95	1.8	3.0	8.0
16.5	13.15	1.8	3.0	8.0
17.0	13.55	1.8	3.0	8.0
17.5	13.95	1.8	3.0	8.0
18.0	14.15	1.8	3.0	8.0
18.5	14.45	1.8	3.0	8.0
19.0	14.75	1.8	3.0	8.0
19.5	14.95	1.8	3.0	8.0
20.0	15.35	1.8	3.0	8.0
20.5	15.55	1.8	3.0	8.0
21.0	15.95	1.8	3.0	8.0
21.5	16.35	1.8	3.0	8.0
22.0	16.55	1.8	3.0	8.0

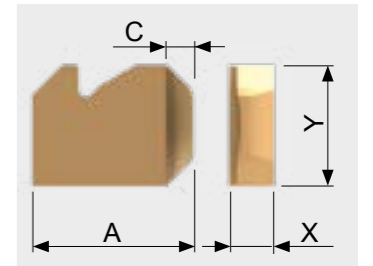

SNAP20, Geometry GS 90°, forward and backward cutting				
Chamfer-Ø	A	C	X	Y
21.0	16.95	2.5	5.0	10.0
22.0	17.45	2.5	5.0	10.0
23.0	17.95	2.5	5.0	10.0
24.0	18.45	2.5	5.0	10.0
25.0	19.95	2.5	5.0	10.0
26.0	20.45	2.5	5.0	10.0
27.0	20.95	2.5	5.0	10.0
28.0	21.45	2.5	5.0	10.0
29.0	21.95	2.5	5.0	10.0
30.0	23.45	2.5	5.0	10.0
31.0	23.95	2.5	5.0	10.0
32.0	24.45	2.5	5.0	10.0
33.0	24.95	2.5	5.0	10.0
34.0	25.45	2.5	5.0	10.0
35.0	26.95	2.5	5.0	10.0
36.0	27.45	2.5	5.0	10.0
37.0	27.95	2.5	5.0	10.0
38.0	28.45	2.5	5.0	10.0

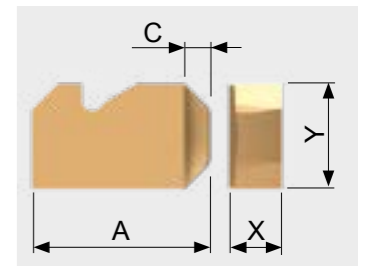

SNAP Thread Blades, Geometry GS 90°, forward and backward cutting				
Chamfer-Ø	A	C	X	Y
Ø2.8 (M2.5)	1.97	0.65	1.0	2.0
Ø3.4 (M3)	2.42	0.775	1.0	2.0
Ø4.5 (M4)	3.14	1.05	1.0	3.0
Ø5.6 (M5)	3.94	1.2	1.0	4.0

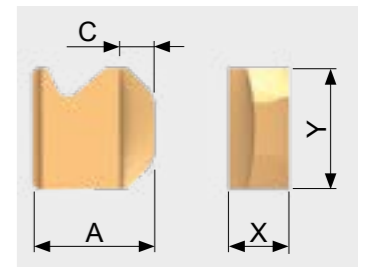

SNAP Thread Blades, Geometry DRA 90°, forward and backward cutting				
Chamfer-Ø	A	C	X	Y
Ø6.5 (M6)	4.8	1.5	3.0	5.5
Ø8.5 (M8)	6.6	1.7	3.0	5.5
Ø10.5 (M10)	7.2	1.9	3.0	5.5
Ø12.5 (M12)	8.7	2.1	3.0	5.5
Ø14.5 (M14)	11.2	2.1	3.0	5.5

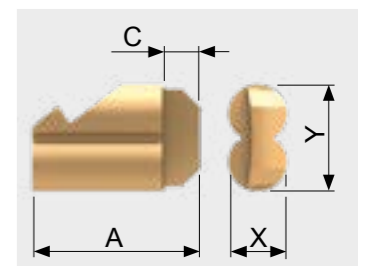

Dimension Table (continued)

SNAP5 Cassette Blades, Geometry GS, forward and backward cutting				
Chamfer-Ø	A	C	X	Y
0.5	6.15	1.25	3.0	5.5
1.0	6.65	1.75	3.0	5.5
1.5	7.10	2.20	3.0	5.5

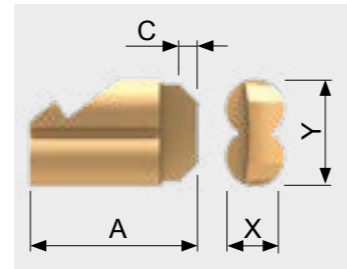

SNAP20 Cassette Blades, Geometry GS, forward and backward cutting				
Chamfer-Ø	A	C	X	Y
0.5	15.5	1.8	5.0	10.0
1.0	16.0	2.3	5.0	10.0
1.5	16.5	2.8	5.0	10.0

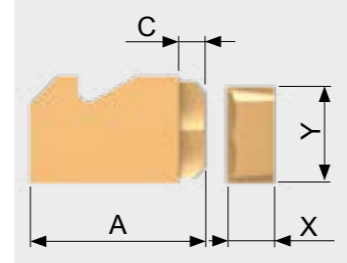

Technical Information

FAQ SNAP

Problem	Reasons	Solution
Burr is not ground away	<ul style="list-style-type: none"> See points below: chamfer too small or no chamfer at all 	⇒ Choose blade for larger chamfer
Chamfer tool small	<ul style="list-style-type: none"> Selected blade too small Feed rate too high 	⇒ Choose blade for larger chamfer ⇒ Reduce feed rate
No chamfer	<ul style="list-style-type: none"> Blade force too small 	⇒ Turn set screw clockwise to increase blade force, only possible when using SNAP GS blades
	<ul style="list-style-type: none"> Blade is blunt 	⇒ Put in new blade
	<ul style="list-style-type: none"> Too large burr formation 	⇒ Replace drilling tool
Different chamfer size at the front and the back side	<ul style="list-style-type: none"> Feed rate varies from the front side to the back side Varying burr formation forwards and backwards 	⇒ Select constant feed rate forwards and backwards, only possible when using SNAP GS blades ⇒ Reduce feed rate on the side with the too small chamfer, only possible when using SNAP GS blades ⇒ Increase feed rate on the side with too large chamfer, only possible when using SNAP GS blades
Chamfer with chatter marks	<ul style="list-style-type: none"> Workpiece or tool not secured properly Tool in unstable condition Speed too high 	⇒ Ensure workpiece or tool is properly secured ⇒ Increase feed rate of tool and check blade force ⇒ Reduce speed
No constant chamfer size	<ul style="list-style-type: none"> Varying feed rates Blade force insufficient not allowing blade to extend fully to starting position every time Tool in unstable condition 	⇒ Choose constant feed rate ⇒ Turn set screw clockwise to increase blade force ⇒ Increase blade force and feed rate
Poor blade life	<ul style="list-style-type: none"> Workpiece or tool not secured properly (Vibrations) Insufficient stability of machine (wear of spindle, etc.) Wrong blade coating 	⇒ Ensure workpiece or tool is properly secured ⇒ Recondition/rectify machine faults or guide in hole with special tool ⇒ Choose other coating



DEFA Online Information



Product Video

www.heule.com/en/chamfering-tool/defa



Case Studies

www.heule.com/en/case-studies/



Contact Sales Represent.

www.heule.com/en/contact-sales-representatives



Request for Quote Form

www.heule.com/en/request-for-quote/



Manual

www.heule.com/en/service/manual/defa



DEFA

Precision chamfering of tough materials,
front and back in one operation.

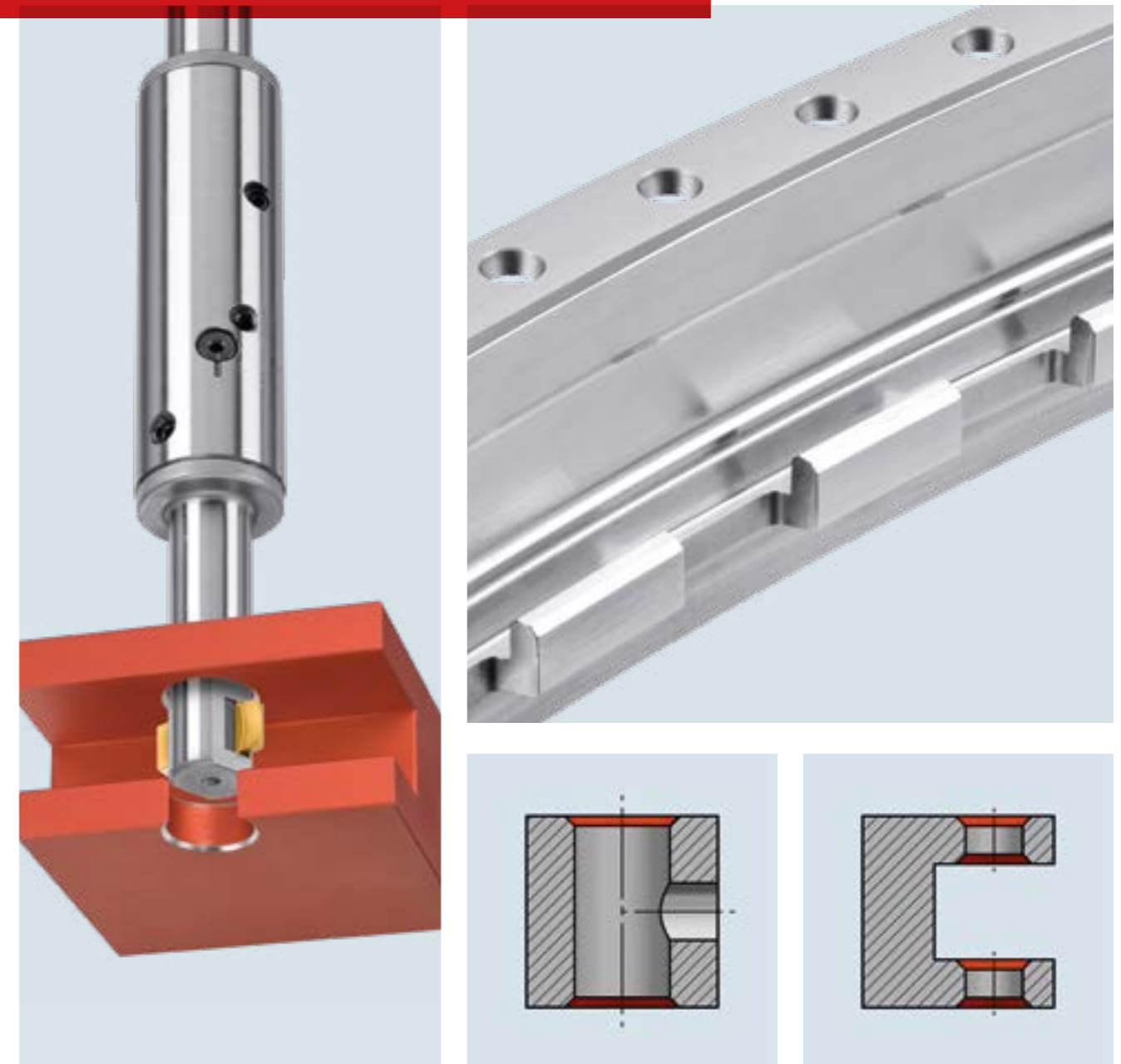

DEFA

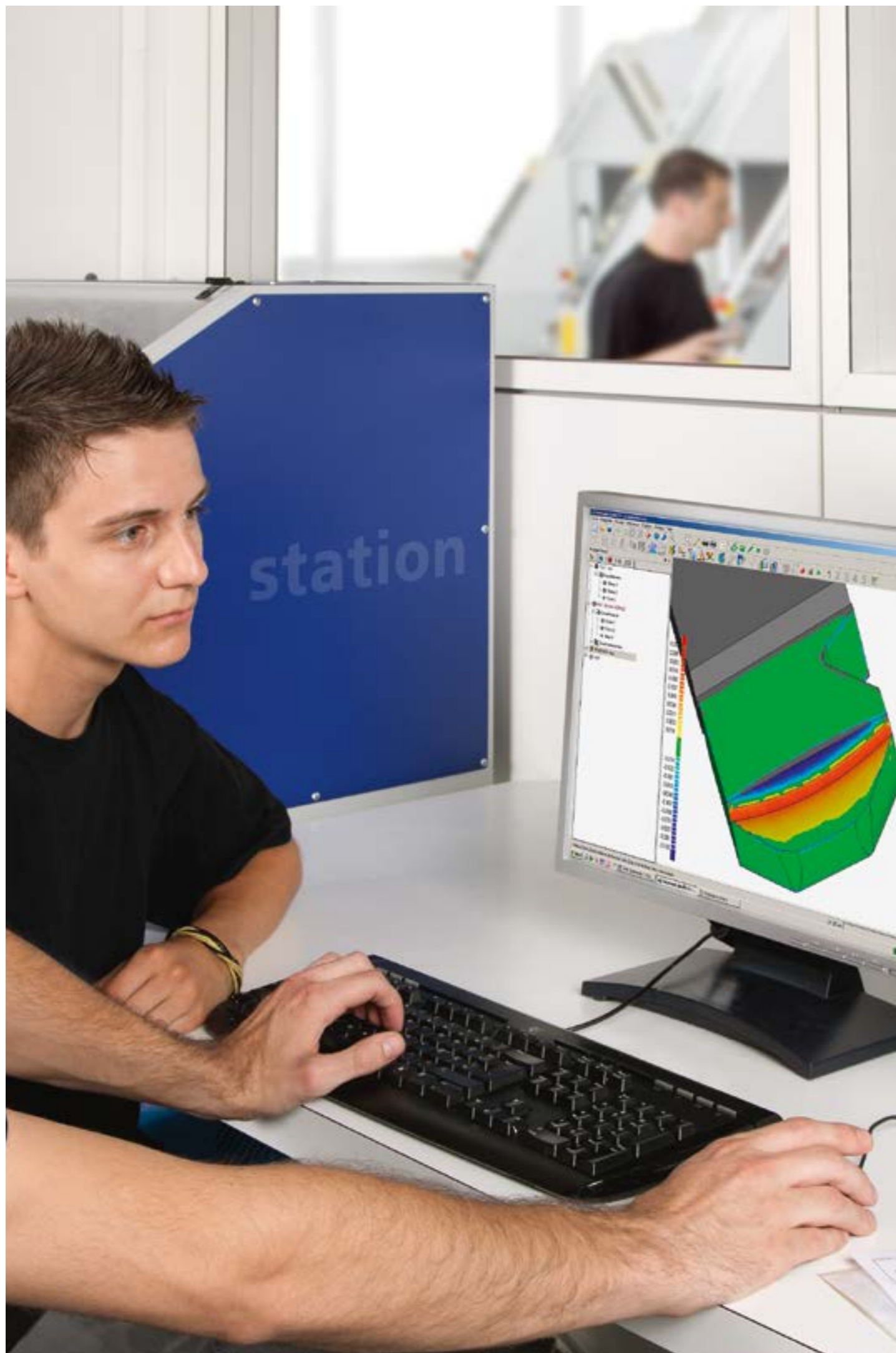

Introduction

DEFA – Chamfering with high dimensional accuracy



Adjustable precision chamfering of interrupted bore edges, front and back in *ONE OPERATION*.

DEFA allows the chamfering of asymmetric interrupted bore edges – front and back in one single pass. Without stopping or reversing the spindle, the double bladed tool creates predefined chamfers. The chamfer diameter can be adjusted on the tool. The DEFA is distinguished by the secondary burr-free bore edges even when used for hard-to-machine materials involving large burrs.

Characteristics and Advantages

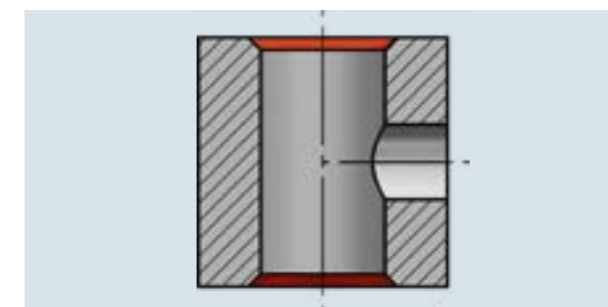

- Front and back or back-only chamfering of interrupted bore edges in one single pass.
- Dual cutting system for machining bores for precise chamfer diameters and high-grade chamfer surfaces.

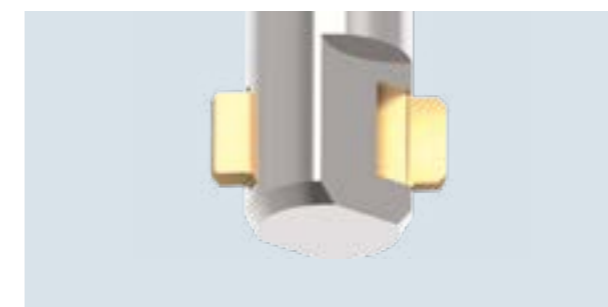

- Chamfer diameter can be continuously adjusted directly on the tool, depending on the bore dimension.
- Exchangeable carbide blades with material-specific coating.

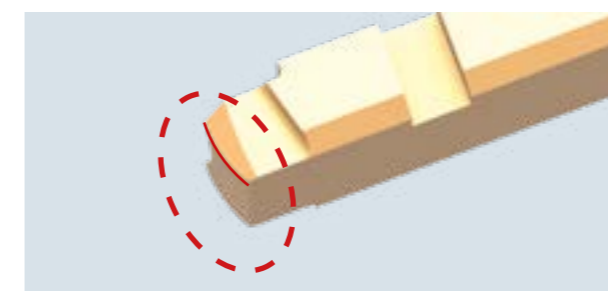

- No damage to the bore surface or the thread during penetration due to the spherical shape.

Tool Description

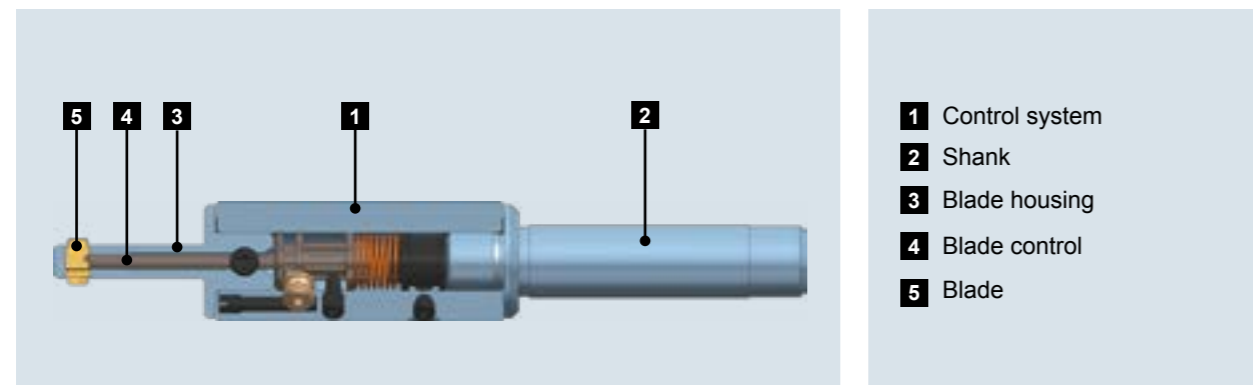

The DEFA chamfering tool is distinguished by its two blades featuring a special geometry. Inside the blade housing, they are held by a preloaded control bolt allowing them to deflect. The two blades are

rigidly interconnected. By turning the set screw the blade diameter can be adjusted synchronously and steplessly to preset the chamfer size.

Function Principle

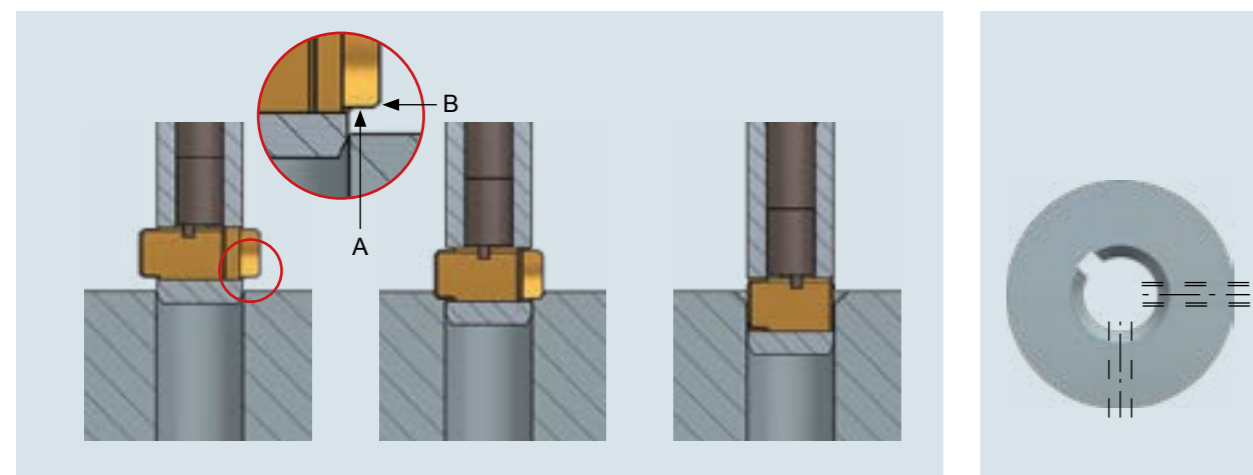

Fig. 1: Function principle DEFA tool

Fig. 2: Top view of workpiece with longitudinal groove and cross bores into main bore

The DEFA chamfering tool is specially designed to chamfer a range of sizes on both the front and back of the bore regardless of burr size.

The cutting edges (A, fig. 1) remove burrs of any size along the plane of the workpiece surface, front and back. As the angular non-cutting definition surface of the blades (B, fig. 2) touches the workpiece material, the blades are simultaneously retracted radially into the blade housing, creating the predetermined chamfer diameter.

In the bore, the rounded surface geometry on the end of the blades prevents any damage to the bore surface.

Since the two blades are rigidly interconnected, it is possible to machine bores with a longitudinal slot or cross hole. Additionally, this feature allows the traversing of the bore without spindle stop. (see fig. 2).

Process Steps Description

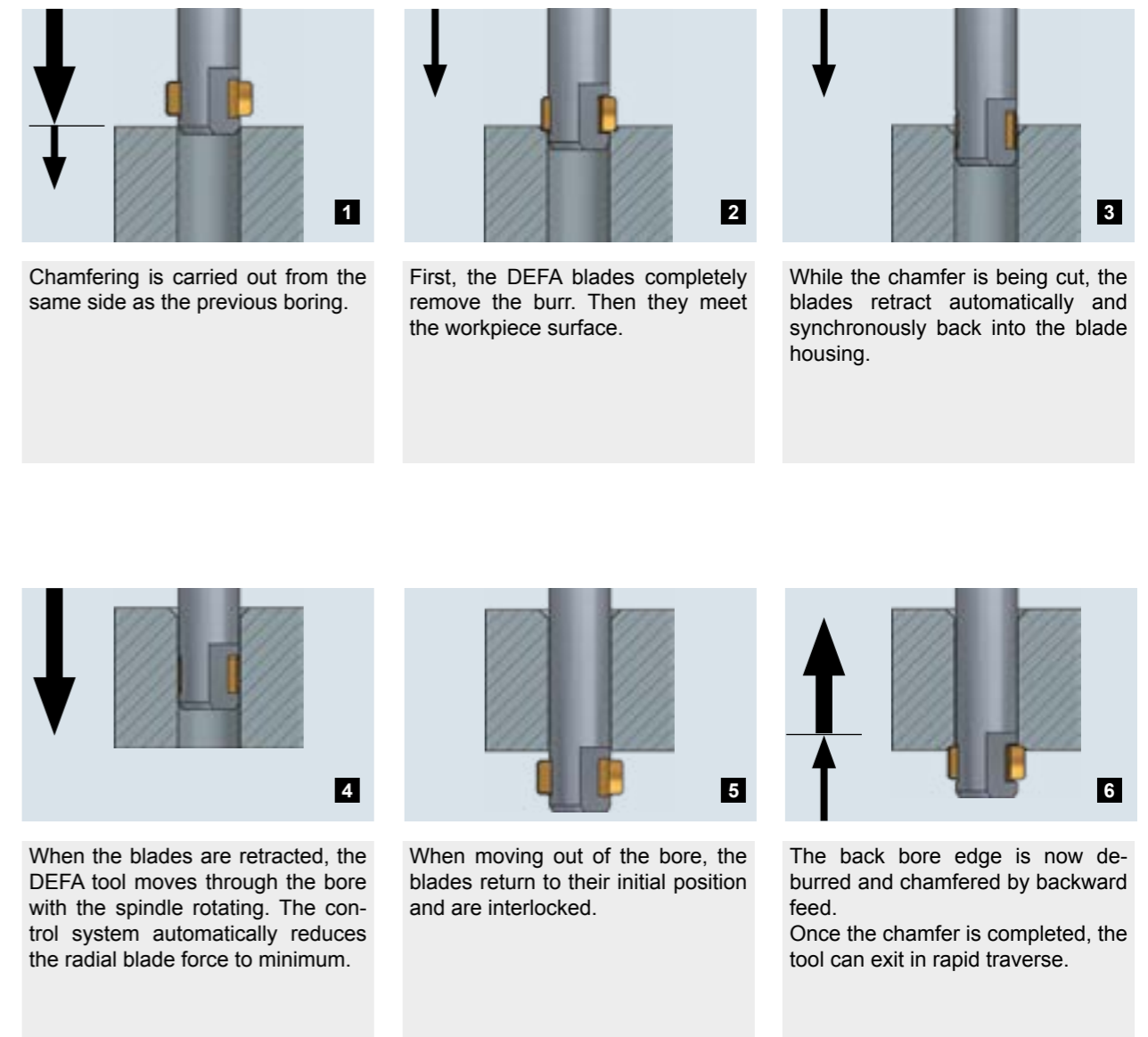

DEFA Range Summary

The DEFA range consists of three tool series. options that cover a small bore diameter range. Within these series there are diverse diameter



Bore	Chamfer Capacity	Tool Series
Ø 4.0 – Ø 6.6 mm	0.1 – 0.6 mm	DEFA 4 - 6
Ø 6.0 – Ø 10.1 mm	0.1 – 0.85 mm	DEFA 6 - 10
Ø 9.0 – Ø 23.9 mm	0.1 – 2.0 mm	DEFA 9 - 24

Part No.: Tool without Blade

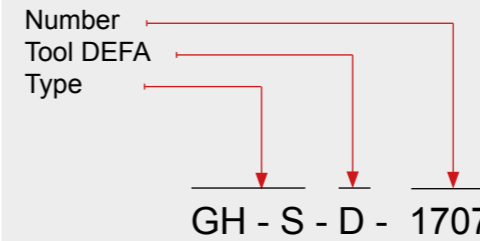

Part No.: Blade

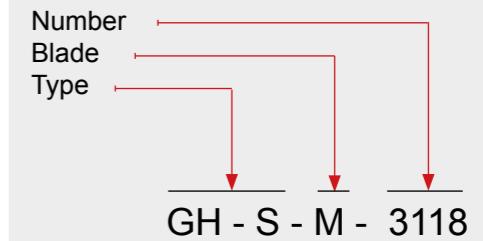

Tool designation

This is the descriptive tool name in contrast to the non-descriptive part number.

Bore range

Defines the application range of the tool with reference to the bore diameter.

Note: Do not reference below minimum values.

Chamfer range

Shows the range of possible chamfer diameters.

Blade housing LN

The blade housing determines the working length of the tool. It is chosen as short as possible, depending on the bore depth (stability reasons) and as long as needed.

Ordering information

For a tool ready for operation you always need:

- Tool without blade, without shank
- Blades
- Shank

Order Example 1

Requirements: Chamfer 0.5x45°, Ø20.0 mm on front and back bore edge
Bore-Ø: Ø19.0 mm
Material: Grey cast
Working length: 30.0 mm
Adaption: cylind. shank Ø12.0 mm

Selection:
Tool: DEFA 17-21/30
 Part No. GH-S-D-1697
Blades: DEFA 17-21 carbide 90°
 Part No. GH-S-M-3918
Shank: cylindrical Ø12.0 mm
 Part No. GH-S-S-0013

Order Example 2

Requirements: Chamfer 1.5x45°, Ø22.0 mm on front and back bore edge
Bore-Ø: Ø19.0 mm
Material: Grey cast
Working length: 30.0 mm
Adaption: cylind. shank Ø12.0 mm

Selection:
Tool: DEFA 19-24/30
 Part No. GH-S-D-1698
Blades: DEFA 19-24 carbide 90°
 Part No. GH-S-M-3919
Shank: cylindrical Ø12.0 mm
 Part No. GH-S-S-0013

DEFA Chamfering Tools 4 - 6

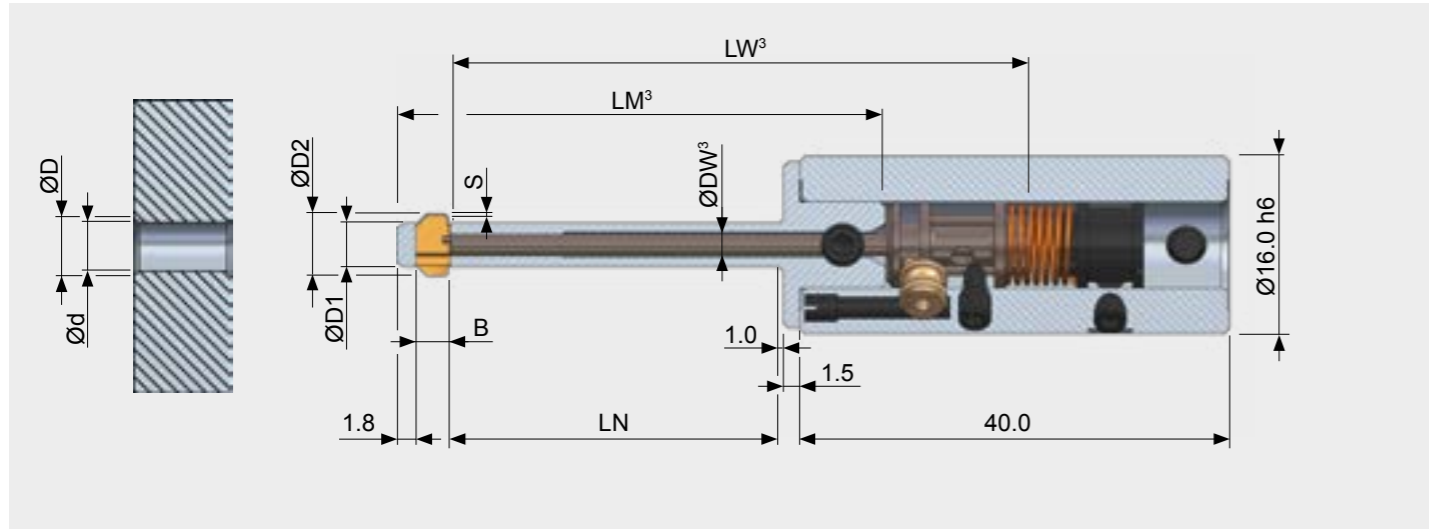

Tool Table

Tool designation	Bore range Ød ¹	Chamfer range ØD	Blade housing ØD1	max. ØD2	B	S	LN	Tool without Blade without Shank
								Part No.
4.0 - 4.8/30	4.0 - 4.6	4.4 - 4.8	3.8	5.4	3.2	0.3	30.0	GH-S-D-5200
4.0 - 4.8/60							60.0	GH-S-D-5201
4.2 - 5.2/30	4.2 - 5.0	4.6 - 5.2	4.1	5.8	3.2	0.3	30.0	GH-S-D-5202
4.2 - 5.2/60							60.0	GH-S-D-5203
4.6 - 5.8/30	4.6 - 5.6	5.0 - 5.8	4.5	6.4	3.2	0.3	30.0	GH-S-D-5204
4.6 - 5.8/60							60.0	GH-S-D-5205
5.0 - 6.4/30	5.0 - 6.2	5.4 - 6.4	4.8	7.0	3.2	0.3	30.0	GH-S-D-5206
5.0 - 6.4/60							60.0	GH-S-D-5207
5.5 - 6.8/30	5.5 - 6.6	5.9 - 6.8	5.3	7.4	3.2	0.3	30.0	GH-S-D-5208
5.5 - 6.8/60							60.0	GH-S-D-5209

¹⁾ Shall not be less.

²⁾ The data for these dimensions are listed on page 125ff.

ORDERING INFORMATION

- The tools are **without blade** and **without shank**. The blades and the shank need to be ordered separately. Please refer to the following page.
- In case the tool body serves for clamping, an end plug is required (please see page 129).

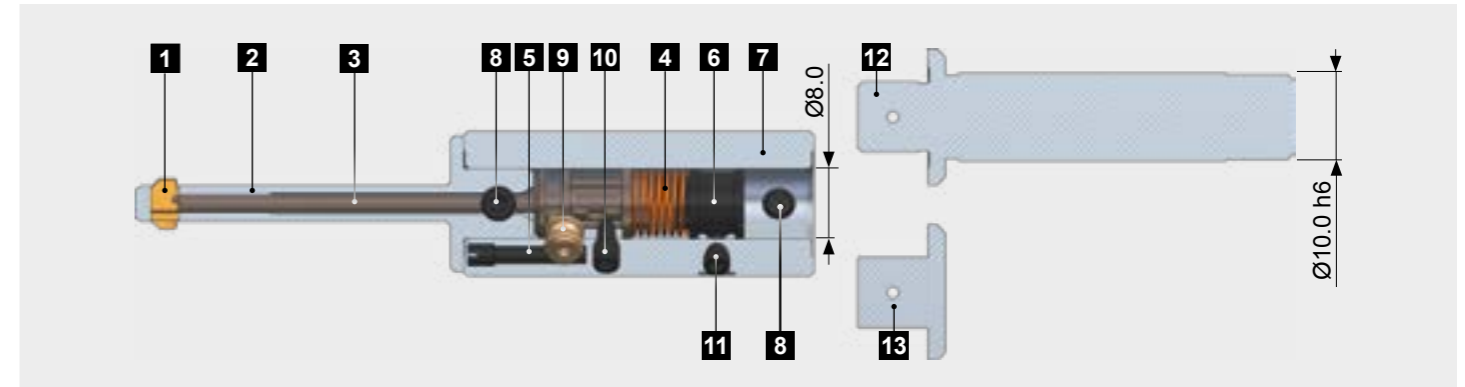

Spare Parts

Pos.	Description	Part No.
1	Blade	see below
2	Blade housing	see page 125
3	Blade control	see page 125
4	Torsion spring 4-6	GH-S-T-0001
5	Positioning screw 4-6	GH-S-X-0001
6	Gear wheel 4-6	GH-S-C-0001
7	Tool body 4-6	GH-S-G-0217
8	Clamping screw M4x0.5x5.0	GH-H-S-0201
9	Eccentric cam 4-6	GH-S-E-0001
10	Set screw 4-6	GH-H-S-1126
11	Tension screw 4-6	GH-H-S-0101
12	Shank cylindrical Ø10.0 h6	GH-S-S-0001
13	End plug Ø8.0	GH-S-S-0090

Blades DF Geometry 90°

DEFA	Part No.	
	forward and backward cutting Coating T ¹	backward cutting only Coating T ¹
4.0 - 4.8	GH-S-M-3902*	GH-S-M-4902
4.2 - 5.2	GH-S-M-3903*	GH-S-M-4903
4.6 - 5.8	GH-S-M-3904*	GH-S-M-4904
5.0 - 6.4	GH-S-M-3905*	GH-S-M-4905
5.5 - 6.8	GH-S-M-3906*	GH-S-M-4906

^{*)} Standard items / Please enquire about stock or delivery times for all non-standard blades.

¹⁾ Standard coating

ORDERING INFORMATION

Blades with a different chamfer angle or coatings for materials with increased requirements (i.e. titanium, Inconel) are available on request.

DEFA Chamfering Tools 6 - 10

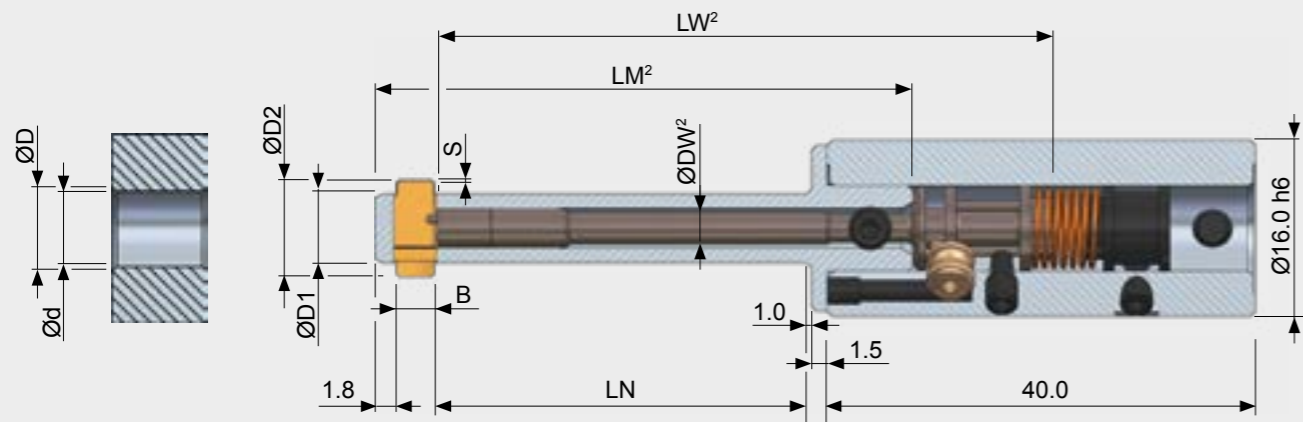

Tool Table

Tool designation	Bore range Ød ¹	Chamfer range ØD	Blade housing ØD1	max. ØD2	B	S	LN	Tool without Blade without Shank
								Part No.
6.0 - 7.0/34	6.0 - 6.5	6.2 - 6.8	5.8	7.4	4.0	0.3	34.0	GH-S-D-5210
6.0 - 7.0/60							60.0	GH-S-D-5211
6.5 - 7.5/34	6.3 - 7.3	6.5 - 7.6	5.8	8.2	4.0	0.3	34.0	GH-S-D-5212
6.5 - 7.5/60							60.0	GH-S-D-5213
7.0 - 8.0/34	6.8 - 8.2	7.0 - 8.5	6.5	9.1	4.0	0.3	34.0	GH-S-D-5214
7.0 - 8.0/60							60.0	GH-S-D-5215
8.0 - 9.5/34	7.7 - 9.3	8.1 - 9.6	7.5	10.4	6.0	0.4	34.0	GH-S-D-5216
8.0 - 9.5/60							60.0	GH-S-D-5217
8.5 - 10.0/34	8.2 - 10.1	8.9 - 10.4	7.5	11.2	6.0	0.4	34.0	GH-S-D-5218
8.5 - 10.0/60							60.0	GH-S-D-5219

¹⁾ Shall not be less.

²⁾ The data for these dimensions are listed on page 125ff.

ORDERING INFORMATION

- The tools are **without blade** and **without shank**. The blades and the shank need to be ordered separately. Please refer to the following page.
- In case the tool body serves for clamping, an end plug is required (please see page 129).

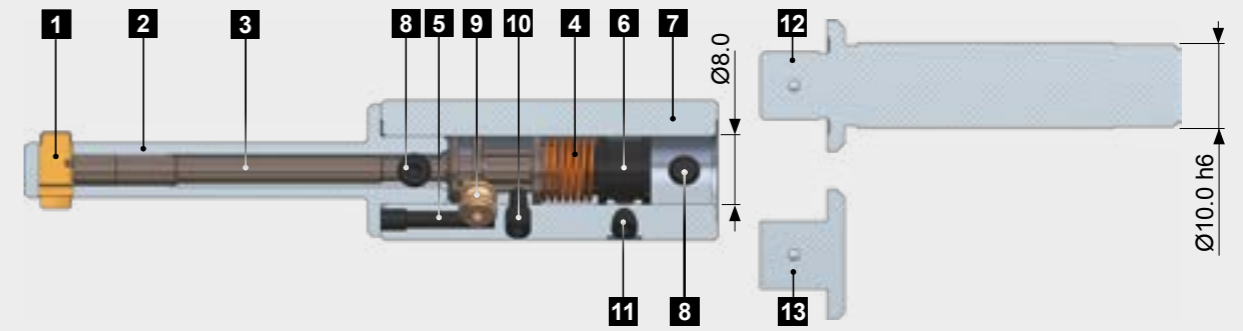

Spare Parts

Pos.	Description	Part No.
1	Blade	see below
2	Blade housing	see page 125
3	Blade control	see page 125
4	Torsion spring 6-10	GH-S-T-0001
5	Positioning screw 6-10	GH-S-X-0001
6	Gear wheel 6-10	GH-S-C-0001
7	Tool body 6-10	GH-S-G-0217
8	Clamping screw M4x0.5x5.0	GH-H-S-0201
9	Excentric cam 6-10	GH-S-E-0001
10	Set screw 6-10	GH-H-S-1126
11	Tension screw 6-10	GH-H-S-0101
12	Shank cylindric Ø10.0 h6	GH-S-S-0001
13	End plug Ø8.0	GH-S-S-0090

Blades DF Geometry 90°

DEFA	Part No.	backward cutting only
	forward and backward cutting	Coating T ²
6.0 - 7.0	GH-S-M-3907*	GH-S-M-4907
6.5 - 7.5	GH-S-M-3908*	GH-S-M-4908
7.0 - 8.0	GH-S-M-3909*	GH-S-M-4909
8.0 - 9.5	GH-S-M-3910*	GH-S-M-4910
8.5 - 10.0	GH-S-M-3911*	GH-S-M-4911

¹⁾ Standard items / Please enquire about stock or delivery times for all non-standard blades.

²⁾ Standard coating

ORDERING INFORMATION

Blades with a different chamfer angle or coatings for materials with increased requirements (i.e. titanium, Inconel) are available on request.

DEFA Chamfering Tools 9 - 24

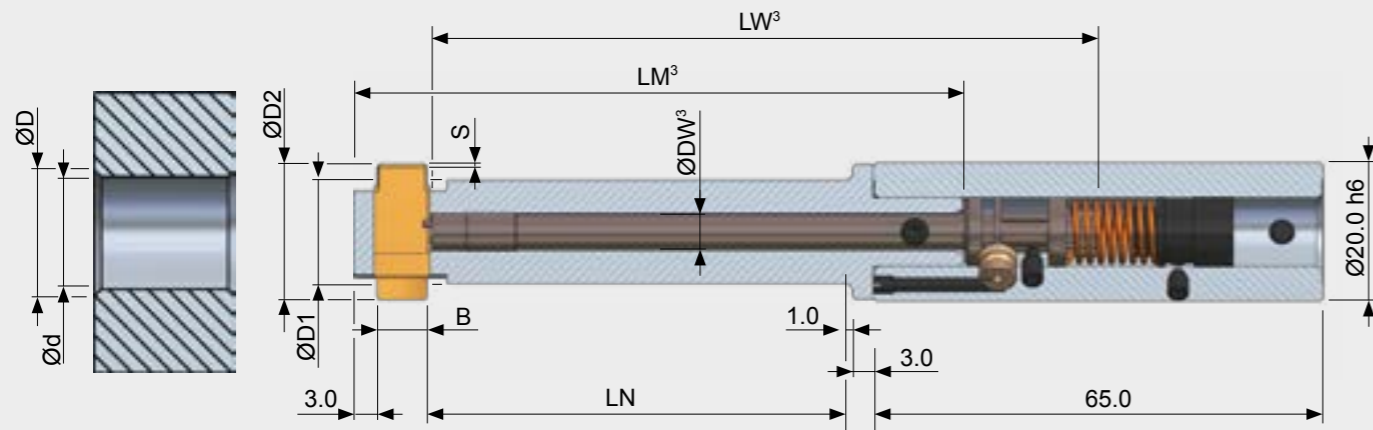

Tool Table

Tool designation	Bore range Ød ¹	Chamfer range ØD	Blade housing ØD1	max. ØD2	B	S	LN	Tool without Blade without Shank
								Part No.
9.0 - 12.0/30	9.0-11.7	10.2-11.4	8.8	12.2	6.0	0.4	30.0	GH-S-D-1707
9.0 - 12.0/60		11.1-12.0 ²		12.8 ²			60.0	GH-S-D-1708
10.0 - 13.0/30	9.7-12.7	11.0-12.4	9.5	13.2	6.0	0.4	30.0	GH-S-D-1709
10.0 - 13.0/60		12.1-13.0 ²		13.8 ²			60.0	GH-S-D-1710
12.0 - 14.0/30	11.2-14.3	12.0-13.8	11.0	14.8	8.0	0.5	30.0	GH-S-D-1711
12.0 - 14.0/60		13.4-14.6 ²		15.6 ²			60.0	GH-S-D-1712
13.0 - 16.0/30	12.2-15.9	13.5-15.4	11.0	16.4	8.0	0.5	30.0	GH-S-D-1713
13.0 - 16.0/60		15.0-16.2 ²		17.2 ²			60.0	GH-S-D-1714
14.0 - 17.0/30	13.2-17.3	15.1-16.6	13.0	17.6	8.0	0.5	30.0	GH-S-D-1695
14.0 - 17.0/60		16.4-17.6 ²		18.6 ²			60.0	GH-S-D-1715
16.0 - 19.0/30	15.2-18.7	16.7-18.2	15.0	19.2	8.0	0.5	30.0	GH-S-D-1696
16.0 - 19.0/60		17.8-19.0 ²		20.0 ²			60.0	GH-S-D-1716
17.0 - 21.0/30	16.7-21.5	18.2-20.4	16.5	22.4	8.0	1.0	30.0	GH-S-D-1697
17.0 - 21.0/60		19.6-21.8 ²		23.8 ²			60.0	GH-S-D-1717
19.0 - 24.0/30	18.7-23.9	20.6-22.8	18.5	24.8	8.0	1.0	30.0	GH-S-D-1698
19.0 - 24.0/60		22.0-24.2 ²		26.2 ²			60.0	GH-S-D-1718

¹ Shall not be less.

² Extended chamfer range: This chamfer range can be attained by using the set screw GH-H-S-0302. For tool order add the extension "-EF" to the tool part number (Order example: GH-S-D-1707-EF). Consultation with HEULE required.

³ The data for these dimensions are listed on page 125ff.

ORDERING INFORMATION

- The tools are **without blade** and **without shank**. The blades and the shank need to be ordered separately. Please refer to the following page.
- In case the tool body serves for clamping, an end plug is required (please see page 129).

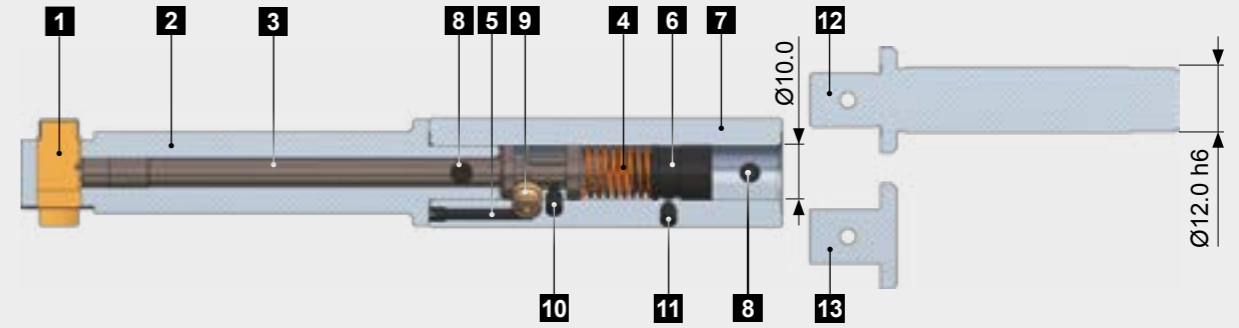

Spare Parts

Pos.	Description	Part No.
1	Blade	see below
2	Blade housing	see page 125
3	Blade control	see page 125
4	Torsion spring 9-28	GH-S-T-0006
5	Positioning screw 9-28	GH-S-X-0006
6	Gear wheel 9-28	GH-S-C-0008
7	Tool body 9-19 Tool body 17-24	GH-S-G-0011 GH-S-G-0013
8	Clamping screw M4x0.5x5.0	GH-H-S-0201
9	Eccentric cam 9-25	GH-S-E-0003
10	Set screw 9-28 Set screw extended chamfer Ø ¹	GH-H-S-0325 GH-H-S-0302
11	Tension screw 9-25	GH-H-S-0102
12	Shank cylindrical Ø12.0 h6	GH-S-S-0013
13	End plug Ø10.0	GH-S-S-0092

¹ Extended chamfer range: This chamfer range can be attained by using the set screw GH-H-S-0302. For tool order add the extension "-EF" to the tool part number (Order example: GH-S-D-1707-EF).

Blades DF Geometry 90°

DEFA	Part No.	
	forward and backward cutting	backward cutting only
	TIN coating ²	TIN coating ²
9.0 - 12.0	GH-S-M-3912*	GH-S-M-4912
10.0 - 13.0	GH-S-M-3913*	GH-S-M-4913
12.0 - 14.0	GH-S-M-3914*	GH-S-M-4914
13.0 - 16.0	GH-S-M-3915*	GH-S-M-4915
14.0 - 17.0	GH-S-M-3916*	GH-S-M-4916
16.0 - 19.0	GH-S-M-3917*	GH-S-M-4917
17.0 - 21.0	GH-S-M-3918*	GH-S-M-4918
19.0 - 24.0	GH-S-M-3919*	GH-S-M-4919

¹ Standard items / Please enquire about stock or delivery times for all non-standard blades.

² Standard coating

ORDERING INFORMATION

Blades with a different chamfer angle or coatings for materials with increased requirements (i.e. titanium, Inconel) are available on request.

Technical Data and Settings

Cutting Data DEFA

Material	Condition	Tensile strength N/mm ²	Hardness HB	DF Geometry		DR Geometry	
				Cutting speed (m/min)	Feed (mm/rev)	Cutting speed (m/min)	Feed (mm/rev)
Unalloyed steel		<500	<150	40-70	0.02-0.06	40-70	0.05-0.1
Cast steel		500 - 850	150 - 250	40-70	0.02-0.06	40-70	0.05-0.1
Grey cast iron		<500	<150	50-90	0.02-0.06	50-90	0.05-0.1
Ductile cast iron		300 - 800	90 - 240	40-70	0.02-0.06	40-70	0.05-0.1
Low alloy steel	annealed	<850	<250	40-70	0.02-0.06	40-70	0.05-0.1
	tempered	850 - 1000	250 - 300	30-50	0.02-0.06	30-50	0.05-0.1
	tempered	>1000 - 1200	>300 - 350	20-40	0.02-0.04	20-40	0.05-0.06
High alloy steel	annealed	<850	<250	20-50	0.02-0.06	20-50	0.05-0.1
	tempered	850 - 1100	250 - 320	15-30	0.02-0.04	15-30	0.02-0.06
Stainless steel	ferritic	450 - 650	130 - 190	15-30	0.02-0.06	15-30	0.05-0.1
	austenitic	650 - 900	190 - 270	10-20	0.02-0.04	10-20	0.05-0.06
	martensitic	500 - 700	150 - 200	15-30	0.02-0.04	15-30	0.02-0.06
Special alloy (Inconel, titanium)		<1200	<350	10-20	0.02-0.04	10-20	0.02-0.06
Wrought or cast aluminium alloys				70-120	0.02-0.1	70-120	0.05-0.2
Copper alloy	Brass			60-90	0.02-0.06	60-90	0.05-0.1
	Bronze short-chipping			30-50	0.02-0.04	30-50	0.05-0.1
	Bronze long-chipping			20-30	0.02-0.04	20-30	0.05-0.1

WARNING NOTICE

All listed cutting data are standard values only! The cutting values depend on the amount of slope of the uneven bore edge. (i.e. high slope ► low cutting value). The feed also depends on the sloping ratio. In case of hard to machine materials or uneven bore edges, we recommend to apply cutting speeds that are at the lower end of the range for uneven bore edges.

Programming Information DEFA

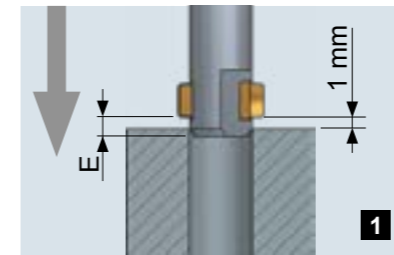

It is not necessary to change the sense of rotation nor to stop the spindle during the whole process. First, rapid traverse of the tool blade above the top material surface of bore or burr.

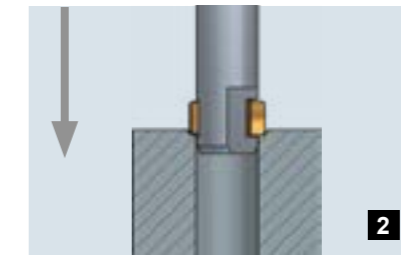

First, the burr of the front bore edge is being removed in working feed. Then, continue in working feed to apply the requested chamfer.

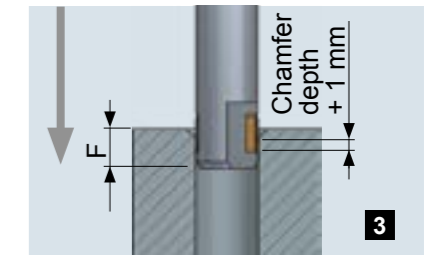

Continue in working feed 1.0 mm farther than the chamfer until the blade is fully retracted.

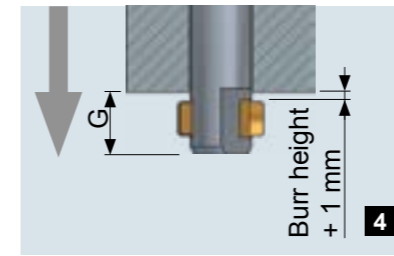

In rapid traverse and without stopping the spindle, you can travel through the hole without damaging its surface. Travel with the blade 1.0 mm behind the back bore edge and possible burrs.

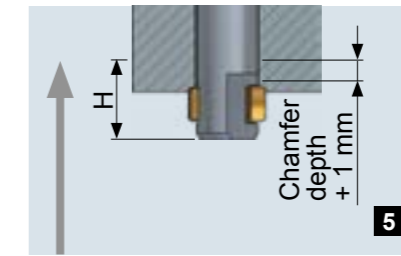

In back working feed the backward chamfer is executed. Proceed with the blade 1.0 mm farther than the planned chamfering depth.

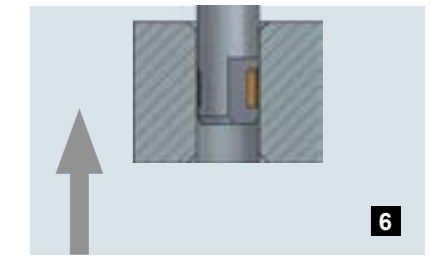

Once the blades are fully retracted, exit in rapid traverse to the next bore.

Dimension Table to Programming Information

Tool	E	F	G	H
DEFA 4-6	0.8	3.4	6.0	3.4
DEFA 6-10	0.8	1.8+(0.5B)	1.8+B+1.0	1.8+(0.5B)
DEFA 9-24	2.0	3.0+(0.5B)	3.0+B+1.0	1.8+(0.5B)

Setting the Blade Force

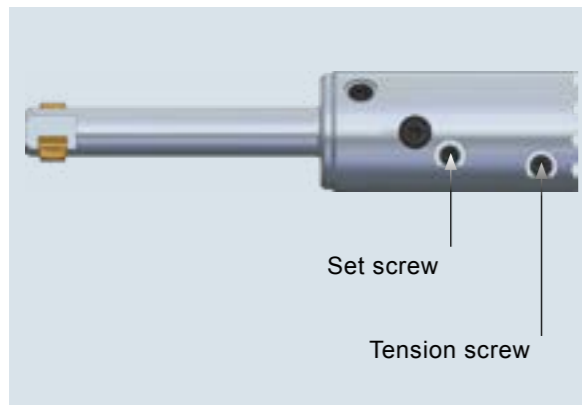

The radial force that acts on the blades has to be strong enough for the blades to fully extend to the set D2 diameter under working conditions (dirt, coolant, etc.). Important: The blade force does not define the chamfer diameter.

Increase blade force:
Turn tension screw clockwise

Reduce blade force:
Turn tension screw counter-clockwise

Blade force standard value: 8-12 N
Dependencies such as material, requirements on the chamfer have to be considered. A test bore is recommended.

NOTE

The blade force does not determine the size of the chamfer!

Setting the Chamfer Size

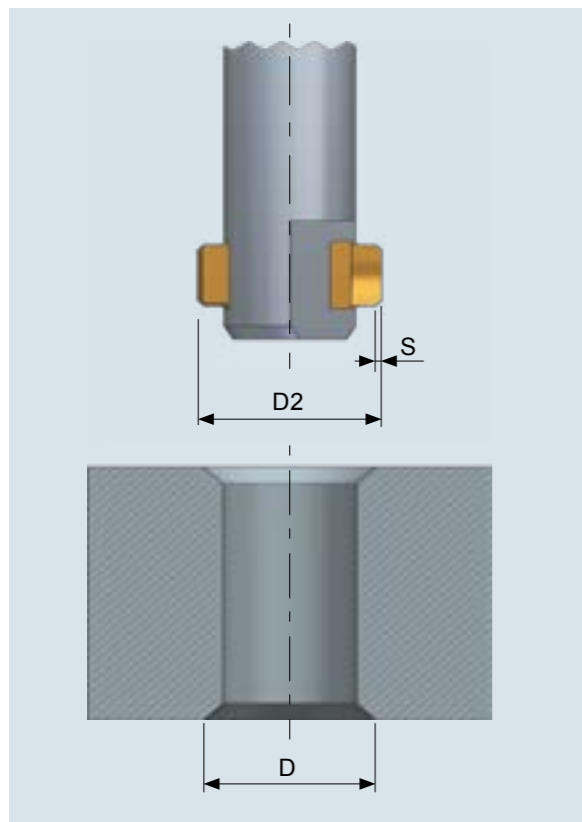

The desired chamfer diameter **D** is set by means of the blade diameter setting **D2**. The maximum D2 (dimensions see tool tables on pages 114-118) must not be exceeded.

D2 = Blade diameter setting
D = Chamfer diameter
s = Definition surface width (see pages 126f.)

$$D2 \approx D + 2s$$

Proceeding:

- Turn set screw with hexagonal wrench until the desired blade diameter setting D2 is obtained (remove the red sealant).
Increase D2 = Turn set screw counter-clockwise
Reduce D2 = Turn set screw clockwise
- Re-seal the set screw.

If the chamfer diameter D varies slightly from the desired diameter, the blade diameter setting can be adjusted accordingly.

NOTE

Please pay attention to the bore hole (d) tolerance (+0.1 mm). Bores with larger tolerance can cause problems (tool is rubbing in the bore, reduced counterbore diameter).

Furthermore, mind the tool collision diameter (counterbore diameter + 2.0 mm) when you move the tool to the tool storage. Reason: The blade can fold out of the blade housing by its own weight.

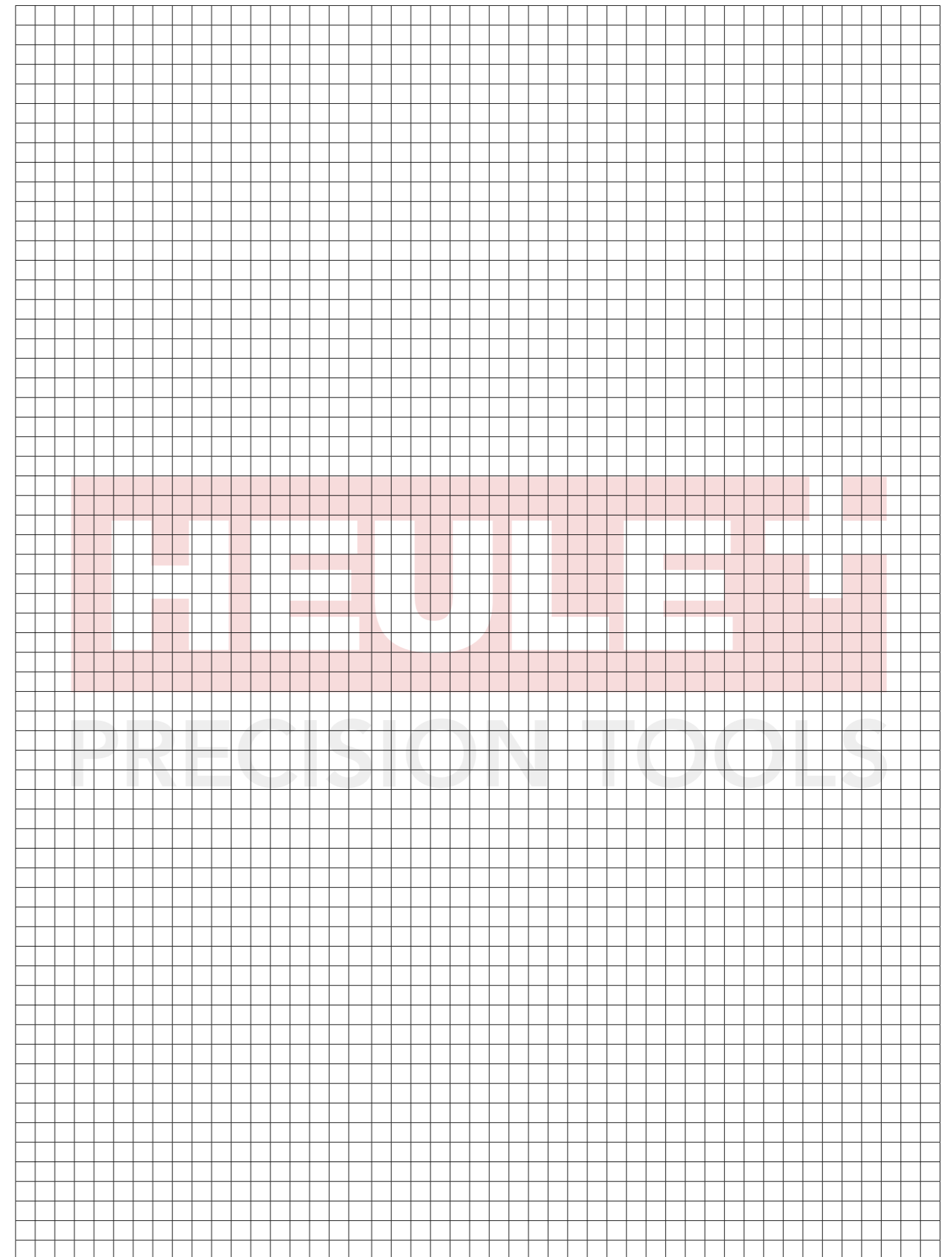

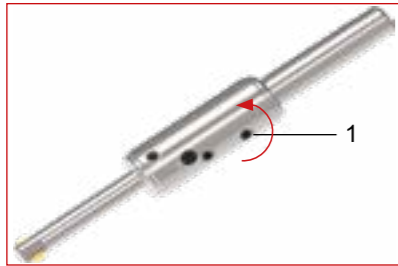

Continue to turn the tension screw counter-clockwise until it is possible to press the blades together **easily** by hand. **Only change the blades when they are slack, i.e. when they are not under tension.**

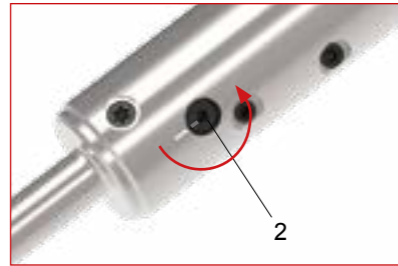

Turn the eccentric cam 180° until the notch is facing opposite of the index.

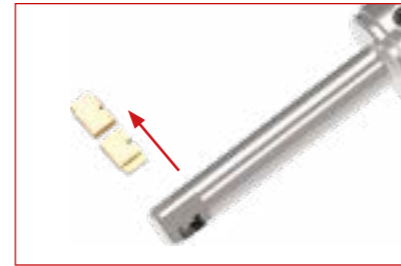

Remove blades from blade housing (by pushing).

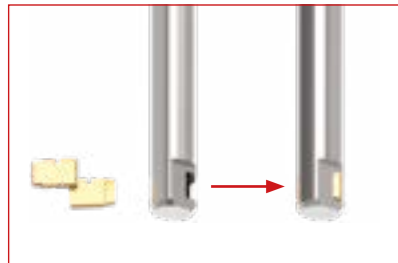

Insert the replacement blades as a pair, cleaned and so that they are approximately flush with the outside diameter of the blade housing.

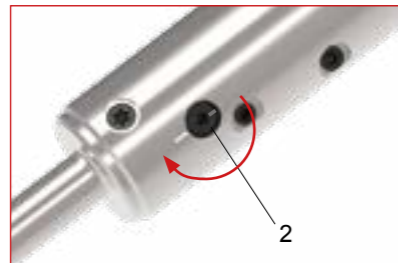

Turn the eccentric cam (2) back to the left until a **slight** resistance is noticed. Finally, both markings are next to each other.

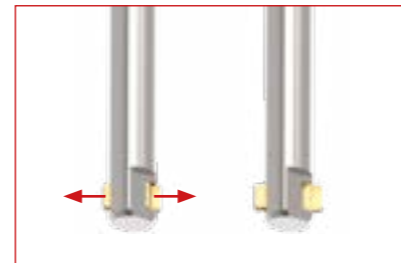

Move the inserted blades outwards (arrow) until they engage automatically.

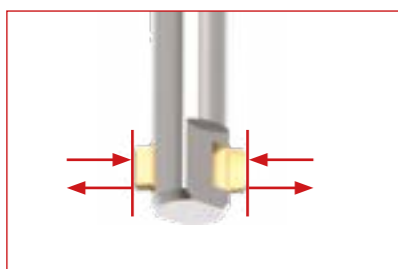

Check: Press both blades with thumb and index finger together. Both blades must move synchronously.



Continue to turn tension screw (1) clockwise until the desired blade force is attained. The previously set chamfer size remains the same before and after changing the blades. For reference values for the blade force please refer to page 122.

Spare Parts

Blade Housing and Blade Control

Tool Ref.	DEFA 4-6 Blade housing with ØD1				DEFA 4-6 Blade control		
	ØD1	LN	LM	Part No.	ØDW	LW	Part No.
4.0 - 4.8/30	3.8	30.0	45.5	GH-S-N-0102	2.0	53.6	GH-S-W-0003
4.0 - 4.8/60	3.8	60.0	75.5	GH-S-N-0132	2.0	83.7	GH-S-W-0027
4.2 - 5.2/30	4.1	30.0	45.5	GH-S-N-0151	2.0	53.6	GH-S-W-0003
4.2 - 5.2/60	4.1	60.0	75.5	GH-S-N-0152	2.0	83.7	GH-S-W-0027
4.6 - 5.8/30	4.5	30.0	45.5	GH-S-N-0154	2.0	53.6	GH-S-W-0003
4.6 - 5.8/60	4.5	60.0	75.5	GH-S-N-0155	2.0	83.7	GH-S-W-0027
5.0 - 6.4/30	4.8	30.0	45.5	GH-S-N-0107	2.0	53.6	GH-S-W-0003
5.0 - 6.4/60	4.8	60.0	75.5	GH-S-N-0134	2.0	83.7	GH-S-W-0027
5.5 - 6.8/30	5.3	30.0	45.5	GH-S-N-0109	2.0	53.6	GH-S-W-0003
5.5 - 6.8/60	5.3	60.0	75.5	GH-S-N-0135	2.0	83.7	GH-S-W-0027

Tool Ref.	DEFA 6-10 Blade housing with ØD1				DEFA 6-10 Blade control		
	ØD1	LN	LM	Part No.	ØDW	LW	Part No.
6.0 - 7.0/34	5.8	34.0	50.3	GH-S-N-0011	3.6	57.4	GH-S-W-0505
6.0 - 7.0/60	5.8	60.0	76.3	GH-S-N-0036	3.6	83.4	GH-S-W-0528
6.5 - 7.5/34	5.8	34.0	50.3	GH-S-N-0111	3.6	57.4	GH-S-W-0505
6.5 - 7.5/60	5.8	60.0	76.3	GH-S-N-0136	3.6	83.4	GH-S-W-0528
7.0 - 8.0/34	6.5	34.0	50.3	GH-S-N-0013	3.6	57.4	GH-S-W-0505
7.0 - 8.0/60	6.5	60.0	76.3	GH-S-N-0137	3.6	83.4	GH-S-W-0528
8.0 - 9.5/34	7.5	34.0	52.3	GH-S-N-0117	3.6	57.4	GH-S-W-0505
8.0 - 9.5/60	7.5	60.0	78.3	GH-S-N-0138	3.6	83.4	GH-S-W-0528
8.5 - 10.0/34	7.5	34.0	52.3	GH-S-N-0084	3.6	57.4	GH-S-W-0505
8.5 - 10.0/60	7.5	60.0	78.3	GH-S-N-0085	3.6	83.4	GH-S-W-0528

Tool Ref.	DEFA 9-24 Blade housing with ØD1				DEFA 9-24 Blade control		
	ØD1	LN	LM	Part No.	ØDW	LW	Part No.
9.0 - 12.0/30	8.8	30.0	56.0	GH-S-N-0074	4.5	65.8	GH-S-W-0508
9.0 - 12.0/60	8.8	60.0	86.0	GH-S-N-0075	4.5	95.8	GH-S-W-0509
10.0 - 13.0/30	9.5	30.0	56.0	GH-S-N-0120	4.5	65.8	GH-S-W-0508
10.0 - 13.0/60	9.5	60.0	86.0	GH-S-N-0121	4.5	95.8	GH-S-W-0509
12.0 - 14.0/30	11.0	30.0	58.0	GH-S-N-0022	5.5	65.8	GH-S-W-0511
12.0 - 14.0/60	11.0	60.0	88.0	GH-S-N-0023	5.5	95.8	GH-S-W-0512
13.0 - 16.0/30	11.0	30.0	58.0	GH-S-N-0122	5.5	65.8	GH-S-W-0511
13.0 - 16.0/60	11.0	60.0	88.0	GH-S-N-0123	5.5	95.8	GH-S-W-0512
14.0 - 17.0/30	13.0	30.0	58.0	GH-S-N-0124	5.5	65.8	GH-S-W-0511
14.0 - 17.0/60	13.0	60.0	88.0	GH-S-N-0125	5.5	95.8	GH-S-W-0512
16.0 - 19.0/30	15.0	30.0	58.0	GH-S-N-0126	5.5	65.8	GH-S-W-0511
16.0 - 19.0/60	15.0	60.0	88.0	GH-S-N-0127	5.5	95.8	GH-S-W-0512
17.0 - 21.0/30	16.5	30.0	58.0	GH-S-N-0128	8.0	65.8	GH-S-W-0520
17.0 - 21.0/60	16.5	60.0	88.0	GH-S-N-0129	8.0	95.8	GH-S-W-0521
19.0 - 24.0/30	18.5	30.0	58.0	GH-S-N-0130	8.0	65.8	GH-S-W-0520
19.0 - 24.0/60	18.5	60.0	88.0	GH-S-N-0131	8.0	95.8	GH-S-W-0521

Blade Dimensions

Dimension Table

DEFA 4-6 90°, forward and backward cutting

Designation	S	A	Ø Chamfer min.-max.	C	G	B	H
4.0 - 4.8	0.3	3.80	4.4 - 4.8	0.8	2.8	3.2	1.0
4.2 - 5.2	0.3	3.95	4.6 - 5.2	1.0	2.8	3.2	1.0
4.6 - 5.8	0.3	4.35	5.0 - 5.8	1.1	2.8	3.2	1.0
5.0 - 6.4	0.3	4.80	5.4 - 6.4	1.2	2.8	3.2	1.0
5.5 - 6.8	0.3	5.00	5.9 - 6.8	1.2	2.8	3.2	1.0

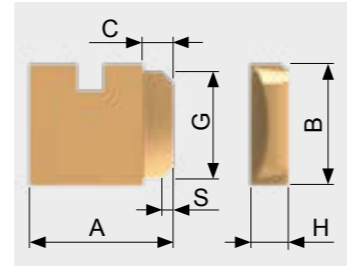

DEFA 4-6 90°, backward cutting only

Designation	S	A	Ø Chamfer min.-max.	C	G	B	H
4.0 - 4.8	0.3	3.80	4.4 - 4.8	0.8	3.0	3.2	1.0
4.2 - 5.2	0.3	3.95	4.6 - 5.2	1.0	3.0	3.2	1.0
4.6 - 5.8	0.3	4.35	5.0 - 5.8	1.1	3.0	3.2	1.0
5.0 - 6.4	0.3	4.80	5.4 - 6.4	1.2	3.0	3.2	1.0
5.5 - 6.8	0.3	5.00	5.9 - 6.8	1.2	3.0	3.2	1.0

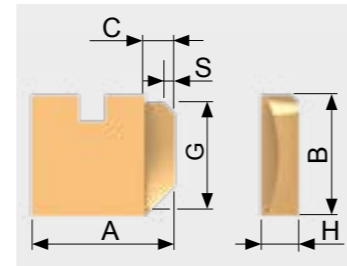

DEFA 6-10 90°, forward and backward cutting

Designation	S	A	Ø Chamfer min.-max.	C	G	B	H
6.0 - 7.0	0.3	5.60	6.2 - 6.8	1.1	3.6	4.0	1.25
6.5 - 7.5	0.3	6.00	6.5 - 7.6	1.4	3.6	4.0	1.25
7.0 - 8.0	0.3	6.45	7.0 - 8.5	1.5	3.6	4.0	1.25
8.0 - 9.5	0.4	7.05	8.1 - 9.6	1.8	5.4	6.0	1.50
8.5 - 10.0	0.4	7.45	8.9 - 10.4	2.0	5.4	6.0	1.50

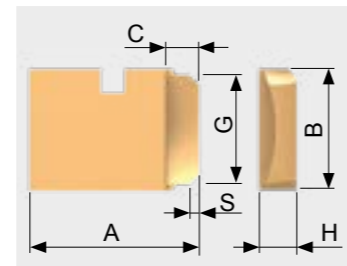

DEFA 6-10 90°, backward cutting only

Designation	S	A	Ø Chamf. min.	C	G	B	H
6.0 - 7.0	0.3	5.60	6.2 - 6.8	1.1	3.8	4.0	1.25
6.5 - 7.5	0.3	6.00	6.5 - 7.6	1.4	3.8	4.0	1.25
7.0 - 8.0	0.3	6.45	7.0 - 8.5	1.5	3.8	4.0	1.25
8.0 - 9.5	0.4	7.05	8.1 - 9.6	1.8	5.7	6.0	1.50
8.5 - 10.0	0.4	7.45	8.9 - 10.4	2.0	5.7	6.0	1.50

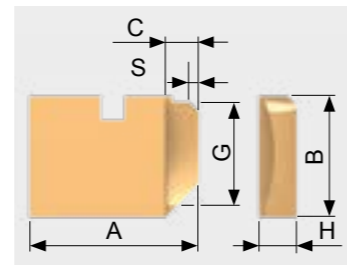

Dimension Table (continued)

DEFA 9-24 90°, forward and backward cutting

Designation	S	A	Ø Chamfer min.-max.	C	G	B	H
9.0 - 12.0	0.4	8.75	10.2 - 12.0 ¹⁾	2.3	5.4	6.0	1.5
10.0 - 13.0	0.4	9.25	11.0 - 13.0 ¹⁾	2.5	5.4	6.0	1.5
12.0 - 14.0	0.5	10.70	12.0 - 14.6 ¹⁾	2.6	7.2	8.0	2.0
13.0 - 16.0	0.5	11.50	13.5 - 16.2 ¹⁾	3.0	7.2	8.0	2.0
14.0 - 17.0	0.5	12.20	15.1 - 17.6 ¹⁾	3.4	7.2	8.0	3.0
16.0 - 19.0	0.5	12.90	16.7 - 19.0 ¹⁾	3.4	7.2	8.0	3.0
17.0 - 21.0	1.0	15.90	18.2 - 21.8 ¹⁾	4.3	7.2	8.0	4.0
19.0 - 24.0	1.0	17.10	20.6 - 24.2 ¹⁾	4.5	7.2	8.0	4.0

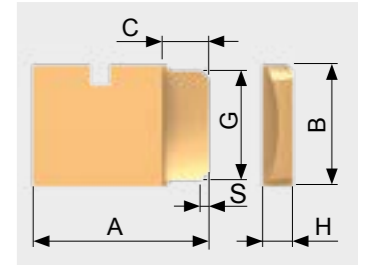

DEFA 9-24 90°, backward cutting only

Designation	S	A	Ø Chamfer min.-max.	C	G	B	H
9.0 - 12.0	0.4	8.75	10.2 - 12.0 ¹⁾	2.3	5.7	6.0	1.5
10.0 - 13.0	0.4	9.25	11.0 - 13.0 ¹⁾	2.5	5.7	6.0	1.5
12.0 - 14.0	0.5	10.70	12.0 - 14.6 ¹⁾	2.6	7.6	8.0	2.0
13.0 - 16.0	0.5	11.50	13.5 - 16.2 ¹⁾	3.0	7.6	8.0	2.0
14.0 - 17.0	0.5	12.20	15.1 - 17.6 ¹⁾	3.4	7.6	8.0	3.0
16.0 - 19.0	0.5	12.90	16.7 - 19.0 ¹⁾	3.4	7.6	8.0	3.0
17.0 - 21.0	1.0	15.90	18.2 - 21.8 ¹⁾	4.3	7.6	8.0	4.0
19.0 - 24.0	1.0	17.10	20.6 - 24.2 ¹⁾	4.5	7.6	8.0	4.0

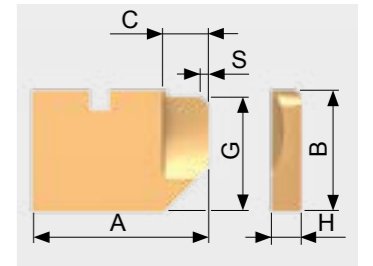

¹⁾ Extended chamfer range

NOTE

In case the desired result cannot be reached with the blades listed above, please contact your HEULE Sales Representative.

Blades with DF Geometry

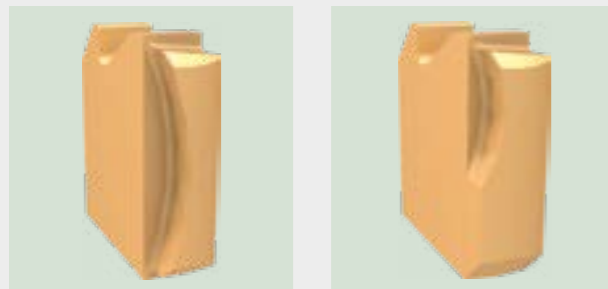

Forward and backward cutting Backward cutting only cutting

Blades with DF geometry are mainly used when a defined, toleranced or consistent chamfer size is required. It is also recommended for use on hard materials or on materials with excessive burr formation.

This blade type is responsive to the condition of the machine such as clamping of workpiece and tool as well as a stable machine spindle etc.

If no front chamfer is required, a **back cutting only blade has to be used.**

The feed rate for blades with DF geometry is from 0.03 mm to 0.1 mm/rev. The upper value should not be exceeded as blade breakage may result.

Blades with DR Geometry



Forward and backward cutting Backward cutting only cutting

Blades with DR Geometry¹ are mainly used when a defined, toleranced chamfer with extremely high requirements is needed. They are favoured when it comes to very tough materials or materials with strong burr formation.

All these blades will be specified according to the application with the support of the design department. Also the cutting data must be defined individually for every new application.

Furthermore, after a first tool/blade trial an additional correction loop must be taken into account. The test results will be analyzed. The corrective actions flow into the development of the customer-specific DR blades.

¹⁾ These special blades are not listed in the catalogue. Please send us your request.

Dimensions of Shanks and End Plugs

Dimension Table

DEFA 4-6 / 6-10	
Shank type	Part No.
Cylindrical Ø10	GH-S-S-0001

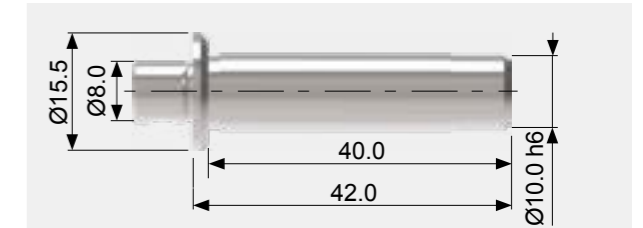

DEFA 9-24	
Shank type	Part No.
Cylindrical Ø12	GH-S-S-0013

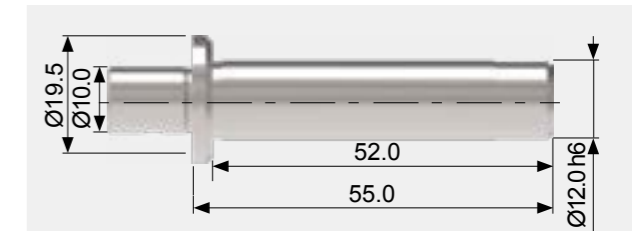

DEFA 4-6 / 6-10	
Shank type	Part No.
End plug Ø8	GH-S-S-0090

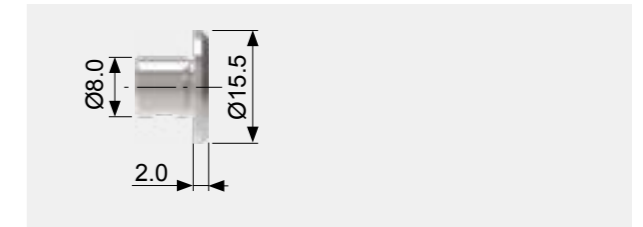

DEFA 9-24	
Shank type	Part No.
End plug Ø10	GH-S-S-0092

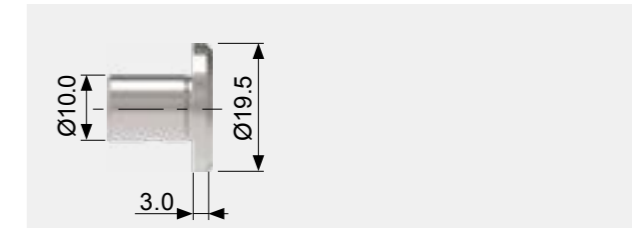



BSF Online Information



Product Video

www.heule.com/en/spotfacing-tool/bsf



Case Studies

www.heule.com/en/case-studies/?t=71



BSF Tool Selector

www.heule.com/en/bsf-tool-selector



Contact Sales Represent.

www.heule.com/en/contact-sales-representatives



Request for Quote Form

www.heule.com/en/request-for-quote



Manual

www.heule.com/en/service/manual/bsf



BSF

Competitive back spotfacing and counterboring tool for counterbores up to 2.3 x bore diameter.

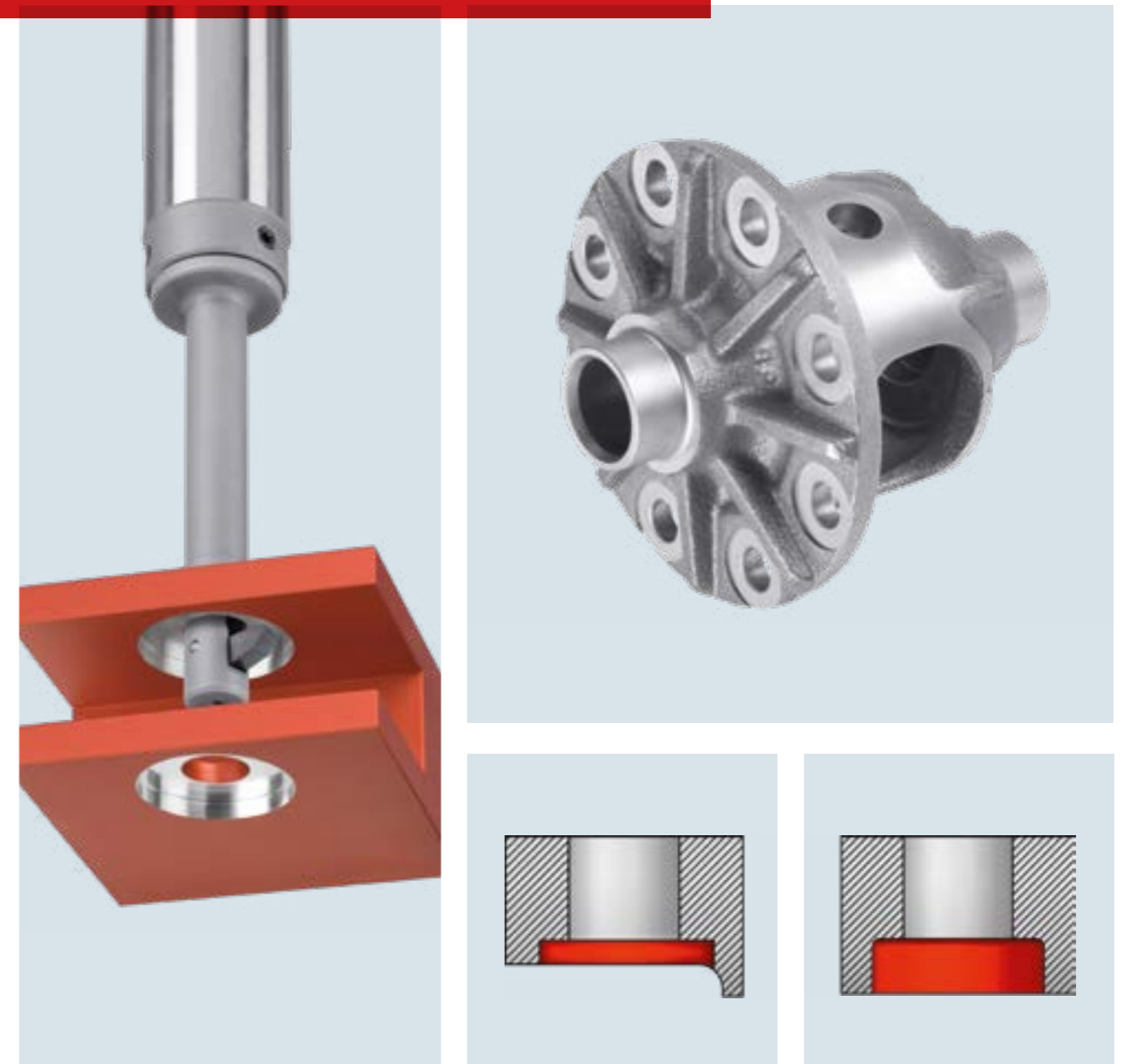

BSF

BSF – The Competitive Back Counterbore Tool



Back Spotfacing up to 2.3 x Bore Diameter

The surprisingly simple BSF tool concept allows back spotfacing or back counterboring in **ONE OPERATION** without turning the workpiece. The robust tool is distinguished by its simplicity and high process capability.

The blade swings out into the working position by the rotation of the spindle. The retraction of the blade is controlled by activating the internal coolant of the machine.

Characteristics and Advantages



- The BSF tool is designed for automatic operation and is immediately ready for service. It works without an anti-rotation device, nor change of turning direction or any machine adaptations.

- The simple swing mechanism combined with the internal coolant pressure system (min. 20 bar, max 50 bar) is granting that neither chips nor dirt remain sticking. Activation by air or microlubrication is available depending on the project.

- The tool change is very simple. Also the other tool components are replaced quickly.

- The tool works vertically and horizontally.

- Standard range with steps of 0.5 mm from bore diameter Ø6.5 mm to Ø21.0 mm.



- Blades are elaborated in carbide for all dimensions, with different coatings.

- Chips and dirt are flushed out of the blade windows thanks to a specifically developed tool geometry. Thus, a high process reliability is granted.



Tool Description

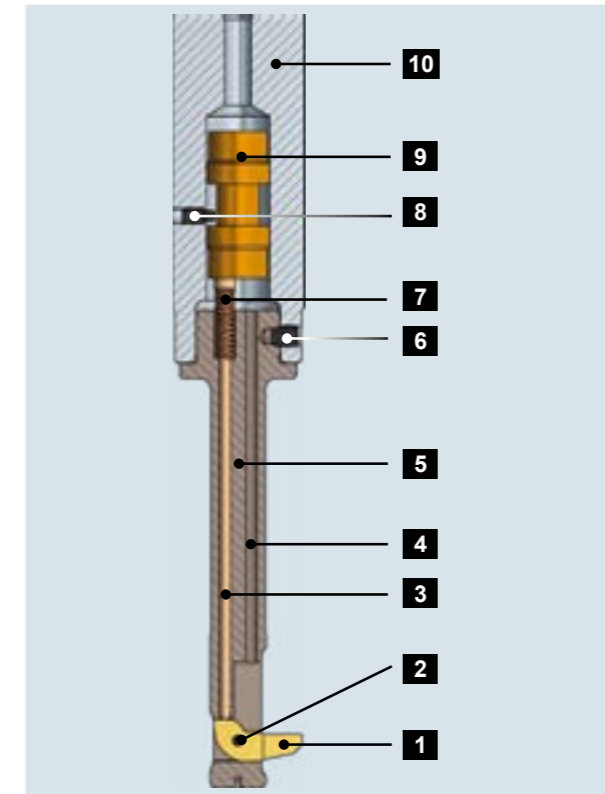

- 1** Blade
- 2** Split pin (always supplied with blade)
- 3** Control pin
- 4** Coolant bore / Internal coolant
- 5** Blade housing
- 6** Clamping screw
- 7** Pressure Spring
- 8** Stop screw for piston system
- 9** Piston
- 10** Shank

Blade Working Principle

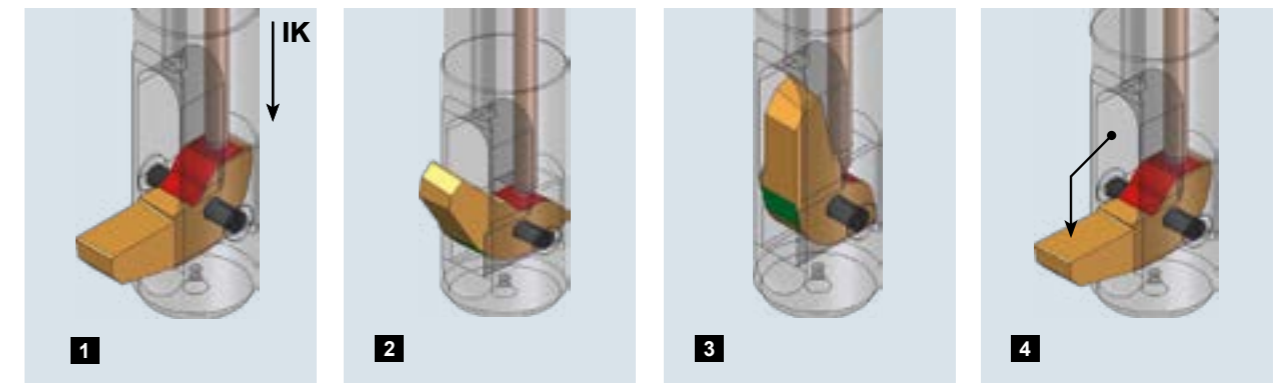

1 The internal coolant builds up pressure on the piston (see tool description position 9). The blade is being folded in by the control pin which presses on the red surface.

2 During the blade movement, the pressure surface of the blade pivots away and the control pin - still under coolant pressure - is now on the blade curve and forces the blade to fully retract.

3 The control pin holds the blade in the retracted position and the tool may be moved in the axial direction (z-axis).

4 When switching off the internal coolant pressure and starting the spindle rotation applying the recommended activation speed, the blade swings out into the working position.

Maximum Slope

Partly interrupted cut (sloping surface) of up to 30° is permitted. If you are working near a radius area do not use internal coolant.

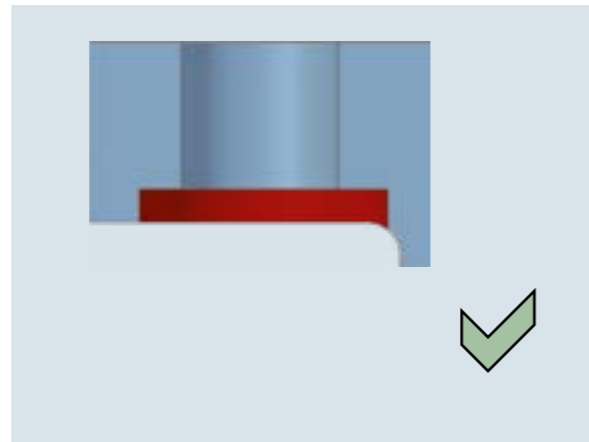
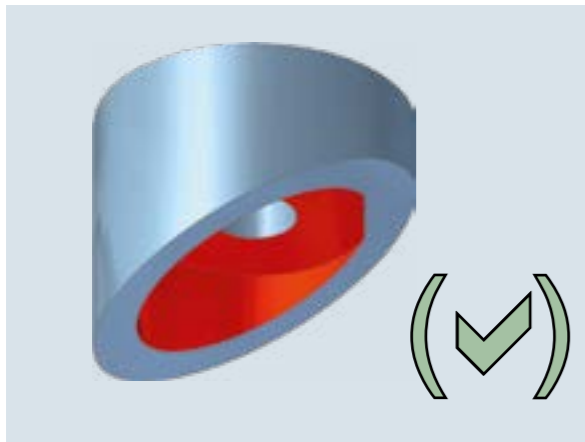

Technical advice is needed on machining capabilities.

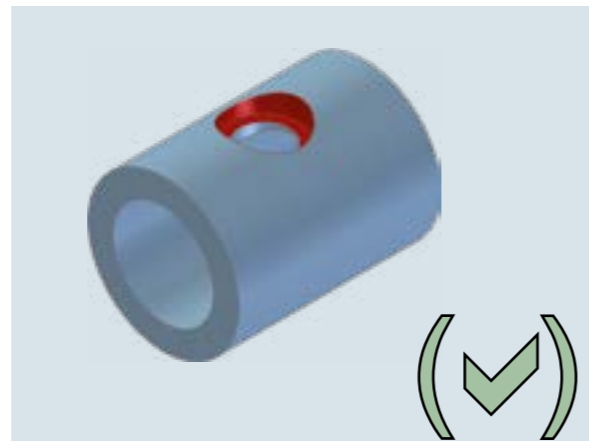
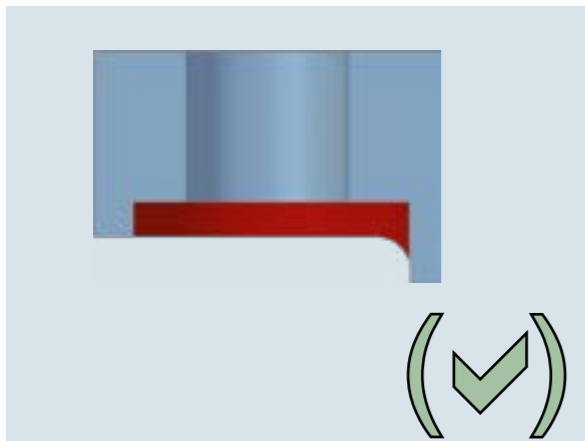

Fully interrupted cut (nut, groove, a. s. o.) is **not possible**.

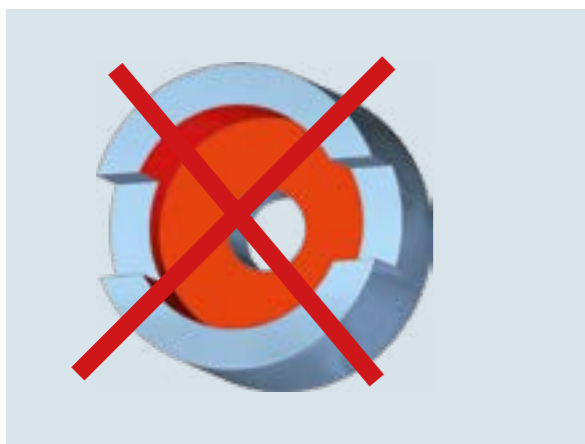

Product Selection

BSF Range Summary

The standardized tool portfolio consists of tools with blades starting from bore diameter Ø6.5 mm up to bore diameter Ø21.0 mm. The attainable back spot facings in this range are 2.3 times the bore diameter as maximum. The right combination of tool and blade is relevant for the function. Therefore, always select blades out of the same series as the tool.

Should the standardized product range not meet your requirements, please do contact HEULE Werkzeug AG. We will gladly accept technical challenges.



Bore Ø	Back Spot Face Ø	Series
6.5 mm to 7.0 mm	9.5 mm to 16.5 mm	Series A
7.5 mm to 8.5 mm	11.0 mm to 20.0 mm	Series B
9.0 mm to 10.0 mm	13.5 mm to 23.0 mm	Series C
10.5 mm to 11.5 mm	15.5 mm to 26.5 mm	Series D
12.0 mm to 14.0 mm	18.0 mm to 32.5 mm	Series E
14.5 mm to 17.0 mm	21.5 mm to 39.5 mm	Series F
17.5 mm to 21.0 mm	26.0 mm to 49.0 mm	Series G

Part No.:
Tool **without blade**

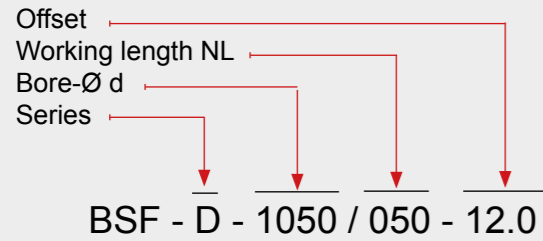

Part No.:
Blade

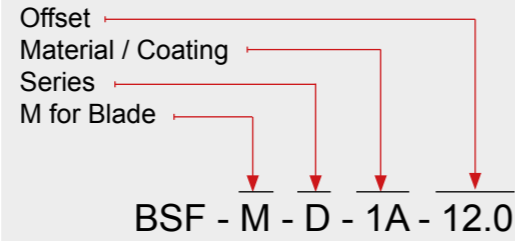

Series

The BSF standard tool system is divided into 7 series (A-G). The series allows a simple tool and blade selection to avoid mistakes when determining blades.

Bore diameter d

The bore diameter is the key parameter for the standardized BSF program. The series corresponds with the bore ranges.

Counterbore diameter D

The counterbore diameter is calculated by adding the offset value of the tool to the offset value of the blade.

Shank system

BSF-tools are executed by default with a cylindrical shank. If requested, they can also be produced with a Weldon shank or a Whistle Notch shank. In this case, please add the suffix "-HB" to the tool part number for a Weldon shank, respectively "-HE" for a Whistle Notch shank.

without suffix = Cylindrical shank (Standard)

HB = Weldon

HE = Whistle Notch

Specific example with Weldon shank:

BSF-D-1050/050-12.0 - **HB**

Explanation how to choose your tool and blade

Please choose your tool with the tables from page 137 on. Look up your bore-Ø first before you decide which counterbore-Ø you need. After these steps you will be able to take your tool and blade number out of the table.

All BSF tools will be supplied without blades. The blade must be determined and ordered separately.

Blade selection / Designation

The part number of the required blade can be taken from the tool table or it can be determined by using the BSF Tool Selector on www.heule.com.

Series

The series steps of the blades are identical with the tool series. For example : an "E" series blade must be chosen for an "E" series tool.

Offset value

The counterbore-Ø can be calculated by adding offset value of the tool to the offset value of the blade, for example 12.0 + 12.0 = counterbore-Ø 24.0 (see above / please refer also to the example on page 154).

Material / Coating

Blade material and coating depend on the application. The standardized blades will be selected accordingly.

Material:

1 = Carbide blade

Coating:

All COFA blades are made of carbide.

The two available coatings are:

A = general (i.e. steel, titanium)

D = Aluminium

BSF Tool for Bore-Ø 6.5 to 7.0 mm

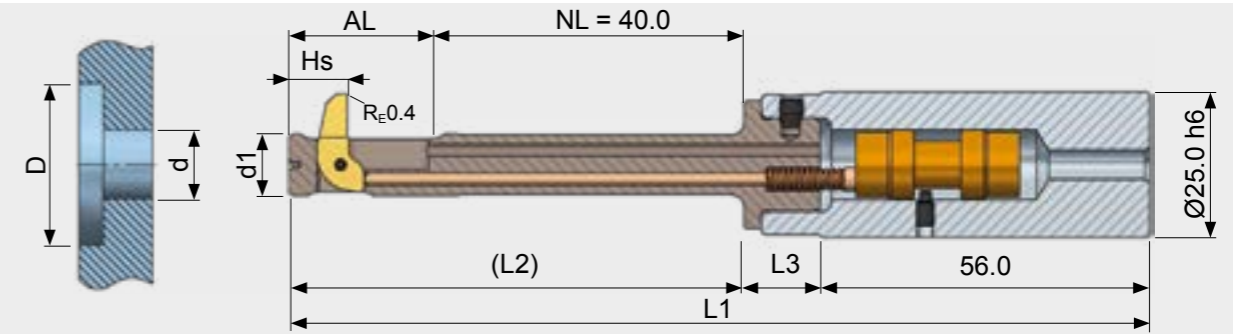

Tool Table

Bore-Ø d	Tool-Ø d1	Counter-bore-Ø D	AL	HS	L1	L2	L3	Tool without Blade	Blade ¹							
								Part No.	Part No.							
6.50	6.40	9.50	14.25	6.15	127.75	58.25	13.50	BSF-A-0650/040-6.5	BSF-M-A-1A-3.0							
								BSF-A-0650/040-7.0								
								BSF-A-0650/040-7.5								
		11.00						BSF-A-0650/040-6.5	BSF-M-A-1A-4.5							
								BSF-A-0650/040-7.0								
								BSF-A-0650/040-7.5								
		12.50						BSF-A-0650/040-6.5	BSF-M-A-1A-6.0							
								BSF-A-0650/040-7.0								
								BSF-A-0650/040-7.5								
		14.00						BSF-A-0650/040-6.5	BSF-M-A-1A-7.5							
								BSF-A-0650/040-7.0								
								BSF-A-0650/040-7.5								
		7.00						6.90	10.00	15.00	6.15	127.75	58.25	13.50	BSF-A-0700/040-7.0	BSF-M-A-1A-3.0
															BSF-A-0700/040-7.5	
															BSF-A-0700/040-8.0	
11.50	BSF-A-0700/040-7.0		BSF-M-A-1A-4.5													
	BSF-A-0700/040-7.5															
	BSF-A-0700/040-8.0															
13.00	BSF-A-0700/040-7.0		BSF-M-A-1A-6.0													
	BSF-A-0700/040-7.5															
	BSF-A-0700/040-8.0															
14.50	BSF-A-0700/040-7.0		BSF-M-A-1A-7.5													
	BSF-A-0700/040-7.5															
	BSF-A-0700/040-8.0															
16.00	BSF-A-0700/040-7.0		BSF-M-A-1A-9.0													
	BSF-A-0700/040-7.5															
	BSF-A-0700/040-7.5															

¹A = Coating for steel alloys, titanium and Inconel / D = Coating for aluminium alloys (please see page 136)

ORDERING INFORMATION

- Standard shank for tool part number without any addition: Cylindrical shank.

With addition: "-HB" = Weldon shank, "-HE" = Whistle Notch shank (please see page 136)

- Attention: The blades for the tool need to be ordered separately.

BSF Tool for Bore-Ø 7.5 to 8.0 mm

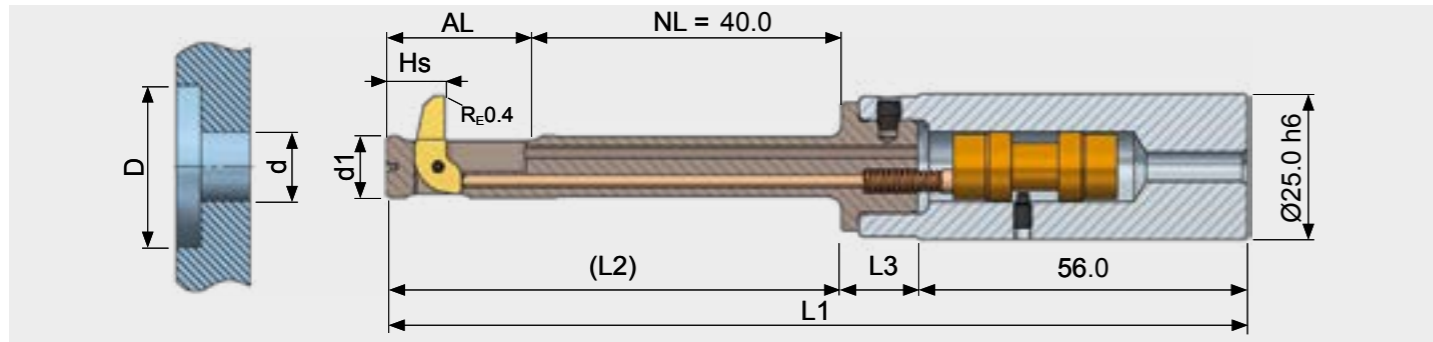

Tool Table

Bore-Ø d	Tool-Ø d1	Counter- bore-Ø D	AL	HS	L1	L2	L3	Tool without Blade	Blade ¹
								Part No.	Part No.
7.50	7.40	11.00	17.00	7.55	130.50	61.00	13.50	BSF-B-0750/040-7.5	BSF-M-B-1A-3.5
		11.50						BSF-B-0750/040-8.0	
		12.00						BSF-B-0750/040-8.5	
	12.50							BSF-B-0750/040-7.5	BSF-M-B-1A-5.0
		13.00						BSF-B-0750/040-8.0	
		13.50						BSF-B-0750/040-8.5	
	14.00							BSF-B-0750/040-7.5	BSF-M-B-1A-6.5
		14.50						BSF-B-0750/040-8.0	
		15.00						BSF-B-0750/040-8.5	
	15.50							BSF-B-0750/040-7.5	BSF-M-B-1A-8.0
		16.00						BSF-B-0750/040-8.0	
		16.50						BSF-B-0750/040-8.5	
	17.00							BSF-B-0750/040-7.5	BSF-M-B-1A-9.5
		17.50						BSF-B-0750/040-8.0	
		8.00	7.90	11.50					BSF-B-0800/040-8.0
12.00							BSF-B-0800/040-8.5		
12.50							BSF-B-0800/040-9.0		
13.00							BSF-B-0800/040-8.0	BSF-M-B-1A-5.0	
	13.50						BSF-B-0800/040-8.5		
	14.00						BSF-B-0800/040-9.0		
14.50							BSF-B-0800/040-8.0	BSF-M-B-1A-6.5	
	15.00						BSF-B-0800/040-8.5		
	15.50						BSF-B-0800/040-9.0		
16.00							BSF-B-0800/040-8.0	BSF-M-B-1A-8.0	
	16.50						BSF-B-0800/040-8.5		
	17.00						BSF-B-0800/040-9.0		
17.50							BSF-B-0800/040-8.0	BSF-M-B-1A-9.5	
	18.00						BSF-B-0800/040-8.5		
	18.50						BSF-B-0800/040-9.0		

¹A = Coating for steel alloys, titanium and Inconel / D = Coating for aluminium alloys (please see page 136)

ORDERING INFORMATION

- Standard shank for tool part number without any addition: Cylindrical shank.
- With addition: "-HB" = Weldon shank, "-HE" = Whistle Notch shank (please see page 136)
- Attention: The blades for the tool need to be ordered separately.

BSF Tool for Bore-Ø 8.5 mm

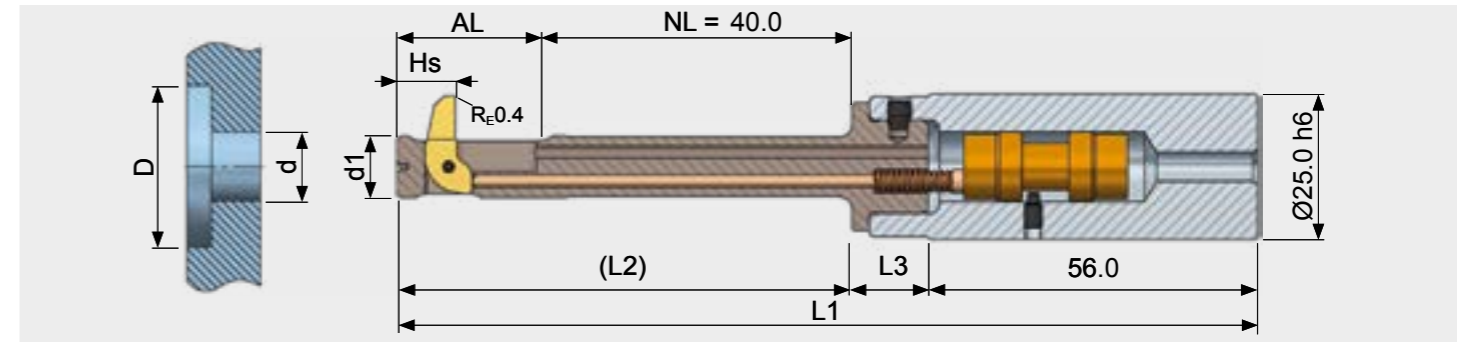

Tool Table

Bore-Ø d	Tool-Ø d1	Counter- bore-Ø D	AL	HS	L1	L2	L3	Tool without Blade	Blade ¹
								Part No.	Part No.
8.50	8.40	12.00	17.75	7.55	131.25	61.75	13.50	BSF-B-0850/040-8.5	BSF-M-B-1A-3.5
		12.50						BSF-B-0850/040-9.0	
		13.00						BSF-B-0850/040-9.5	
	13.50							BSF-B-0850/040-8.5	BSF-M-B-1A-5.0
		14.00						BSF-B-0850/040-9.0	
		14.50						BSF-B-0850/040-9.5	
	15.00							BSF-B-0850/040-8.5	BSF-M-B-1A-6.5
		15.50						BSF-B-0850/040-9.0	
		16.00						BSF-B-0850/040-9.5	
	16.50							BSF-B-0850/040-8.5	BSF-M-B-1A-8.0
		17.00						BSF-B-0850/040-9.0	
		17.50						BSF-B-0850/040-9.5	
	18.00							BSF-B-0850/040-8.5	BSF-M-B-1A-9.5
		18.50						BSF-B-0850/040-9.0	
		19.00						BSF-B-0850/040-9.5	
19.50							BSF-B-0850/040-8.5	BSF-M-B-1A-11.0	
	20.00						BSF-B-0850/040-9.0		

¹A = Coating for steel alloys, titanium and Inconel / D = Coating for aluminium alloys (please see page 136)

ORDERING INFORMATION

- Standard shank for tool part number without any addition: Cylindrical shank.
- With addition: "-HB" = Weldon shank, "-HE" = Whistle Notch shank (please see page 136)
- Attention: The blades for the tool need to be ordered separately.

BSF Tool for Bore-Ø 9.0 to 9.5 mm

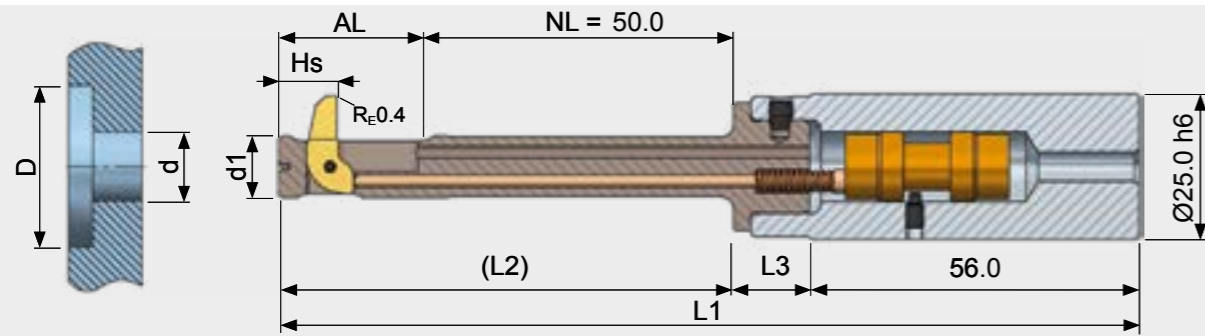

Tool Table

Bore-Ø d	Tool-Ø d1	Counter- bore-Ø D	AL	HS	L1	L2	L3	Tool without Blade	Blade ¹
								Part No.	Part No.
9.00	8.90	13.50	20.25	8.55	143.75	74.25	13.50	BSF-C-0900/050-9.5	BSF-M-C-1A-4.0
		14.00						BSF-C-0900/050-10.0	
		14.50						BSF-C-0900/050-10.5	
		15.00	BSF-C-0900/050-9.5			BSF-M-C-1A-5.5			
		15.50	BSF-C-0900/050-10.0						
		16.00	BSF-C-0900/050-10.5						
		16.50	BSF-C-0900/050-9.5				BSF-M-C-1A-7.0		
		17.00	BSF-C-0900/050-10.0						
		17.50	BSF-C-0900/050-10.5						
		18.00	BSF-C-0900/050-9.5					BSF-M-C-1A-8.5	
		18.50	BSF-C-0900/050-10.0						
		19.00	BSF-C-0900/050-10.5						
		19.50	BSF-C-0900/050-9.5					BSF-M-C-1A-10.0	
		20.00	BSF-C-0900/050-10.0						
		20.50	BSF-C-0900/050-10.5						
21.00	BSF-C-0900/050-9.5						BSF-M-C-1A-11.5		
9.50	9.40	14.00						BSF-C-0950/050-10.0	BSF-M-C-1A-4.0
		14.50						BSF-C-0950/050-10.5	
		15.00						BSF-C-0950/050-11.0	
		15.50						BSF-C-0950/050-10.0	BSF-M-C-1A-5.5
		16.00						BSF-C-0950/050-10.5	
		16.50						BSF-C-0950/050-11.0	
		17.00						BSF-C-0950/050-10.0	BSF-M-C-1A-7.0
		17.50						BSF-C-0950/050-10.5	
		18.00						BSF-C-0950/050-11.0	
		18.50						BSF-C-0950/050-10.0	BSF-M-C-1A-8.5
		19.00						BSF-C-0950/050-10.5	
		19.50						BSF-C-0950/050-11.0	
		20.00						BSF-C-0950/050-10.0	BSF-M-C-1A-10.0
		20.50						BSF-C-0950/050-10.5	
		21.00						BSF-C-0950/050-11.0	
21.50						BSF-C-0950/050-10.0	BSF-M-C-1A-11.5		
22.00						BSF-C-0950/050-10.5			

¹A = Coating for steel alloys, titanium and Inconel / D = Coating for aluminium alloys (please see page 136)

ORDERING INFORMATION

- Standard shank for tool part number without any addition: Cylindrical shank.
- With addition: "-HB" = Weldon shank, "-HE" = Whistle Notch shank (please see page 136)
- Attention: The blades for the tool need to be ordered separately.

BSF Tool for Bore-Ø 10.0 mm

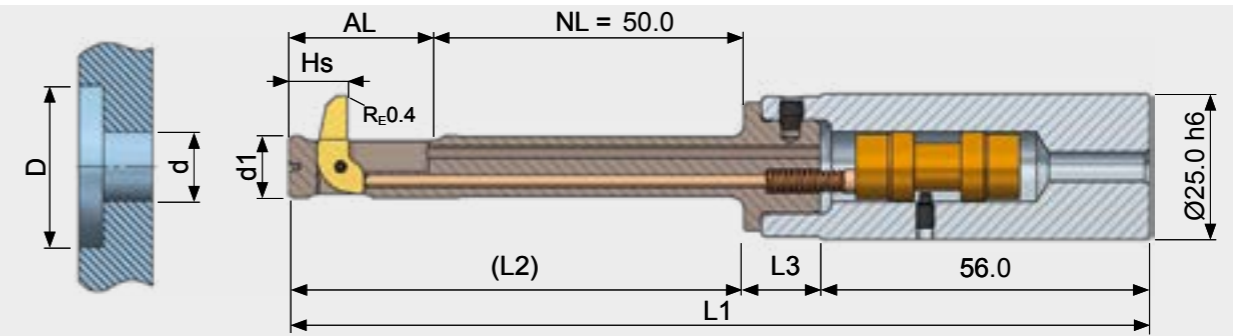

Tool Table

Bore-Ø d	Tool-Ø d1	Counter- bore-Ø D	AL	HS	L1	L2	L3	Tool without Blade	Blade ¹
								Part No.	Part No.
10.00	9.90	14.50	20.25	8.55	143.75	74.25	13.50	BSF-C-1000/050-10.5	BSF-M-C-1A-4.0
		15.00						BSF-C-1000/050-11.0	
		15.50						BSF-C-1000/050-11.5	
		16.00	BSF-C-1000/050-10.5			BSF-M-C-1A-5.5			
		16.50	BSF-C-1000/050-11.0						
		17.00	BSF-C-1000/050-11.5						
		17.50	BSF-C-1000/050-10.5				BSF-M-C-1A-7.0		
		18.00	BSF-C-1000/050-11.0						
		18.50	BSF-C-1000/050-11.5						
		19.00	BSF-C-1000/050-10.5					BSF-M-C-1A-8.5	
		19.50	BSF-C-1000/050-11.0						
		20.00	BSF-C-1000/050-11.5						
		20.50	BSF-C-1000/050-10.5					BSF-M-C-1A-10.0	
		21.00	BSF-C-1000/050-11.0						
		21.50	BSF-C-1000/050-11.5						
22.00	BSF-C-1000/050-10.5						BSF-M-C-1A-11.5		
22.50	BSF-C-1000/050-11.0								
23.00	BSF-C-1000/050-11.5								

¹A = Coating for steel alloys, titanium and Inconel / D = Coating for aluminium alloys (please see page 136)

ORDERING INFORMATION

- Standard shank for tool part number without any addition: Cylindrical shank.
- With addition: "-HB" = Weldon shank, "-HE" = Whistle Notch shank (please see page 136)
- Attention: The blades for the tool need to be ordered separately.

BSF Tool for Bore-Ø 10.5 mm

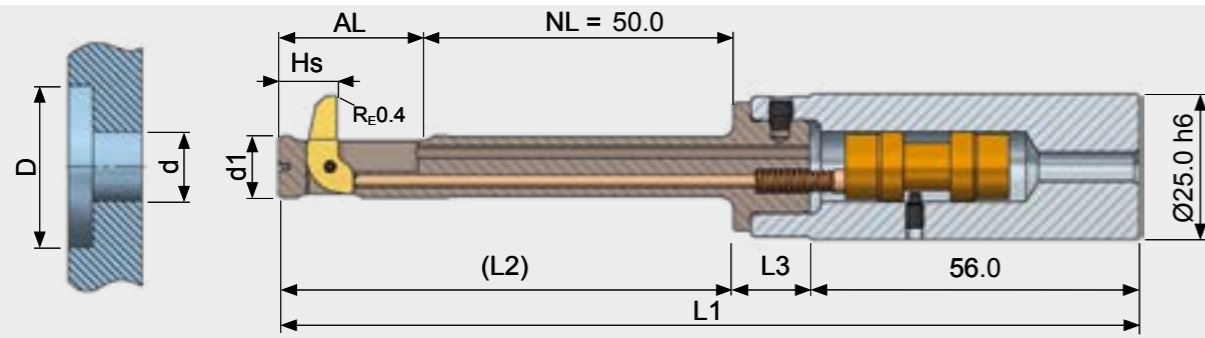

Tool Table

Bore-Ø d	Tool-Ø d1	Counter- bore-Ø D	AL	HS	L1	L2	L3	Tool without Blade		Blade ¹
								Part No.	Part No.	
10.50	10.40	15.50	22.50	9.63	146.00	76.50	13.50	BSF-D-1050/050-11.0		BSF-M-D-1A-4.5
		16.00						BSF-D-1050/050-11.5		
		16.50						BSF-D-1050/050-12.0		
		17.00						BSF-D-1050/050-12.5		
		17.50						BSF-D-1050/050-13.0		
		18.00						BSF-D-1050/050-11.0		BSF-M-D-1A-7.0
		18.50						BSF-D-1050/050-11.5		
		19.00						BSF-D-1050/050-12.0		
		19.50						BSF-D-1050/050-12.5		
		20.00						BSF-D-1050/050-13.0		
		20.50						BSF-D-1050/050-11.0		BSF-M-D-1A-9.5
		21.00						BSF-D-1050/050-11.5		
		21.50						BSF-D-1050/050-12.0		
		22.00						BSF-D-1050/050-12.5		
		22.50						BSF-D-1050/050-13.0		
23.00						BSF-D-1050/050-11.0		BSF-M-D-1A-12.0		
23.50						BSF-D-1050/050-11.5				
24.00						BSF-D-1050/050-12.0				
24.50						BSF-D-1050/050-12.5				

¹A = Coating for steel alloys, titanium and Inconel / D = Coating for aluminium alloys (please see page 136)

ORDERING INFORMATION

- Standard shank for tool part number without any addition: Cylindrical shank.
- With addition: "-HB" = Weldon shank, "-HE" = Whistle Notch shank (please see page 136)
- Attention: The blades for the tool need to be ordered separately.

BSF Tool for Bore-Ø 11.0 mm

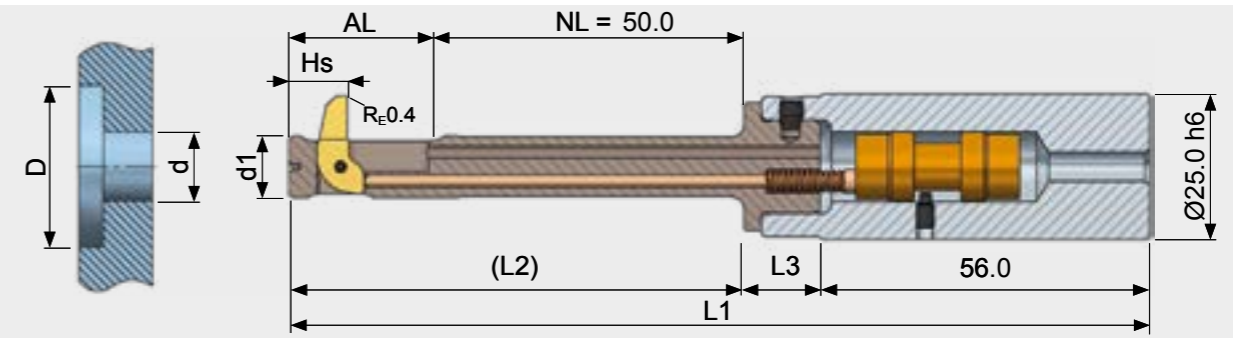

Tool Table

Bore-Ø d	Tool-Ø d1	Counter- bore-Ø D	AL	HS	L1	L2	L3	Tool without Blade		Blade ¹
								Part No.	Part No.	
11.00	10.90	16.00	22.50	9.63	146.00	76.50	13.50	BSF-D-1100/050-11.5		BSF-M-D-1A-4.5
		16.50						BSF-D-1100/050-12.0		
		17.00						BSF-D-1100/050-12.5		
		17.50						BSF-D-1100/050-13.0		
		18.00						BSF-D-1100/050-13.5		
		18.50						BSF-D-1100/050-11.5		BSF-M-D-1A-7.0
		19.00						BSF-D-1100/050-12.0		
		19.50						BSF-D-1100/050-12.5		
		20.00						BSF-D-1100/050-13.0		
		20.50						BSF-D-1100/050-13.5		
		21.00						BSF-D-1100/050-11.5		BSF-M-D-1A-9.5
		21.50						BSF-D-1100/050-12.0		
		22.00						BSF-D-1100/050-12.5		
		22.50						BSF-D-1100/050-13.0		
		23.00						BSF-D-1100/050-13.5		
23.50						BSF-D-1100/050-11.5		BSF-M-D-1A-12.0		
24.00						BSF-D-1100/050-12.0				
24.50						BSF-D-1100/050-12.5				
25.00						BSF-D-1100/050-13.0				
25.50						BSF-D-1100/050-13.5				

¹A = Coating for steel alloys, titanium and Inconel / D = Coating for aluminium alloys (please see page 136)

ORDERING INFORMATION

- Standard shank for tool part number without any addition: Cylindrical shank.
- With addition: "-HB" = Weldon shank, "-HE" = Whistle Notch shank (please see page 136)
- Attention: The blades for the tool need to be ordered separately.

BSF Tool for Bore-Ø 11.5 mm

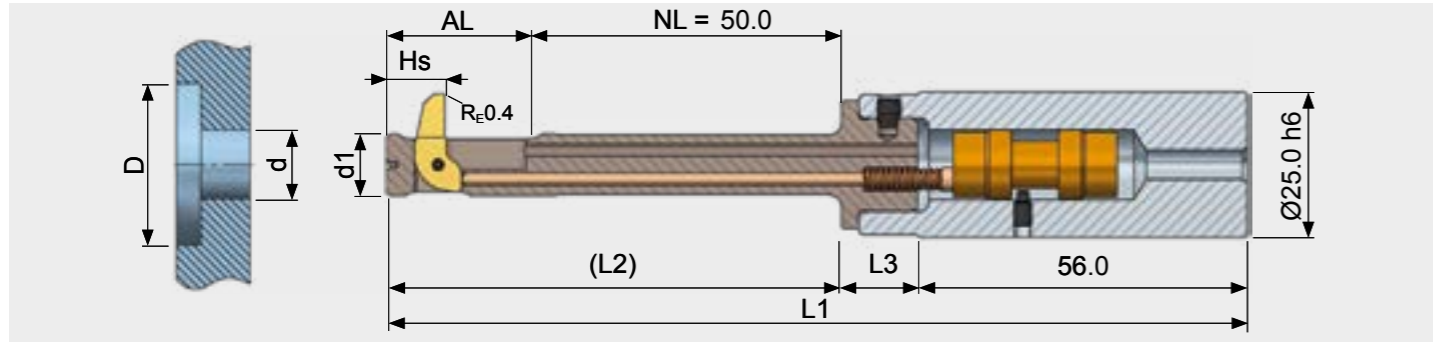

Tool Table

Bore-Ø d	Tool-Ø d1	Counter- bore-Ø D	AL	HS	L1	L2	L3	Tool without Blade		Blade ¹
								Part No.	Part No.	Part No.
11.50	11.40	16.50	23.75	9.63	147.25	77.75	13.50	BSF-D-1150/050-12.0	BSF-M-D-1A-4.5	
		17.00						BSF-D-1150/050-12.5		
		17.50						BSF-D-1150/050-13.0		
		18.00						BSF-D-1150/050-13.5		
		18.50						BSF-D-1150/050-14.0		
		19.00						BSF-D-1150/050-12.0		BSF-M-D-1A-7.0
		19.50						BSF-D-1150/050-12.5		
		20.00						BSF-D-1150/050-13.0		
		20.50						BSF-D-1150/050-13.5		
		21.00						BSF-D-1150/050-14.0		
		21.50						BSF-D-1150/050-12.0	BSF-M-D-1A-9.5	
		22.00						BSF-D-1150/050-12.5		
		22.50						BSF-D-1150/050-13.0		
		23.00						BSF-D-1150/050-13.5		
		23.50						BSF-D-1150/050-14.0		
		24.00						BSF-D-1150/050-12.0	BSF-M-D-1A-12.0	
		24.50						BSF-D-1150/050-12.5		
		25.00						BSF-D-1150/050-13.0		
25.50	BSF-D-1150/050-13.5									
26.00	BSF-D-1150/050-14.0									
26.50	BSF-D-1150/050-12.0	BSF-M-D-1A-14.5								

¹A = Coating for steel alloys, titanium and Inconel / D = Coating for aluminium alloys (please see page 136)

ORDERING INFORMATION

- Standard shank for tool part number without any addition: Cylindrical shank.
- With addition: "-HB" = Weldon shank, "-HE" = Whistle Notch shank (please see page 136)
- Attention: The blades for the tool need to be ordered separately.

BSF Tool for Bore-Ø 12.0 mm

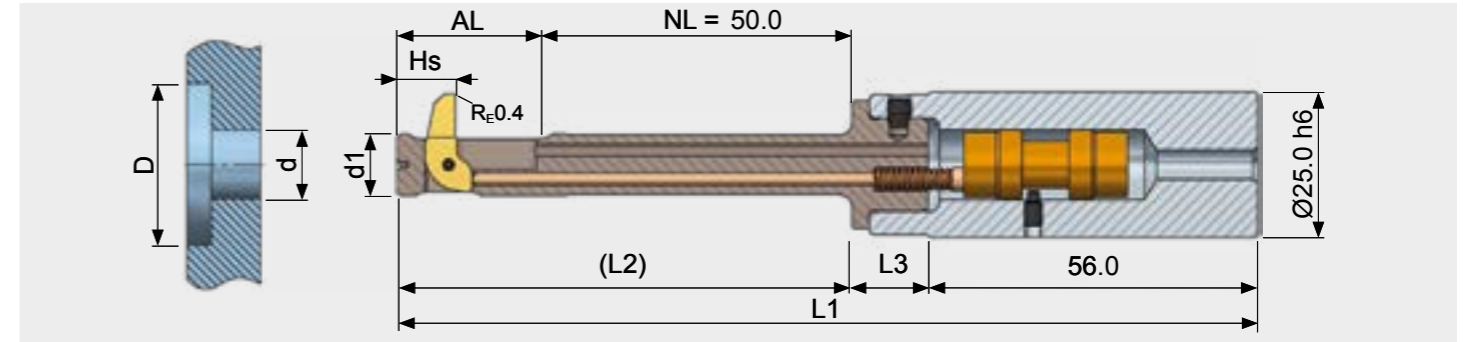

Tool Table

Bore-Ø d	Tool-Ø d1	Counter- bore-Ø D	AL	HS	L1	L2	L3	Tool without Blade		Blade ¹
								Part No.	Part No.	Part No.
12.00	11.90	18.00	26.75	11.40	150.25	80.75	13.50	BSF-E-1200/050-13.0	BSF-M-E-1A-5.0	
		18.50						BSF-E-1200/050-13.5		
		19.00						BSF-E-1200/050-14.0		
		19.50						BSF-E-1200/050-14.5		
		20.00						BSF-E-1200/050-15.0		
		20.50						BSF-E-1200/050-13.0	BSF-M-E-1A-7.5	
		21.00						BSF-E-1200/050-13.5		
		21.50						BSF-E-1200/050-14.0		
		22.00						BSF-E-1200/050-14.5		
		22.50						BSF-E-1200/050-15.0		
		23.00						BSF-E-1200/050-13.0	BSF-M-E-1A-10.0	
		23.50						BSF-E-1200/050-13.5		
		24.00						BSF-E-1200/050-14.0		
		24.50						BSF-E-1200/050-14.5		
		25.00						BSF-E-1200/050-15.0		
		25.50						BSF-E-1200/050-13.0	BSF-M-E-1A-12.5	
		26.00						BSF-E-1200/050-13.5		
		26.50						BSF-E-1200/050-14.0		
27.00	BSF-E-1200/050-14.5									
27.50	BSF-E-1200/050-15.0									
28.00	BSF-E-1200/050-13.0	BSF-M-E-1A-15.0								

¹A = Coating for steel alloys, titanium and Inconel / D = Coating for aluminium alloys (please see page 136)

ORDERING INFORMATION

- Standard shank for tool part number without any addition: Cylindrical shank.
- With addition: "-HB" = Weldon shank, "-HE" = Whistle Notch shank (please see page 136)
- Attention: The blades for the tool need to be ordered separately.

BSF Tool for Bore-Ø 12.5 mm

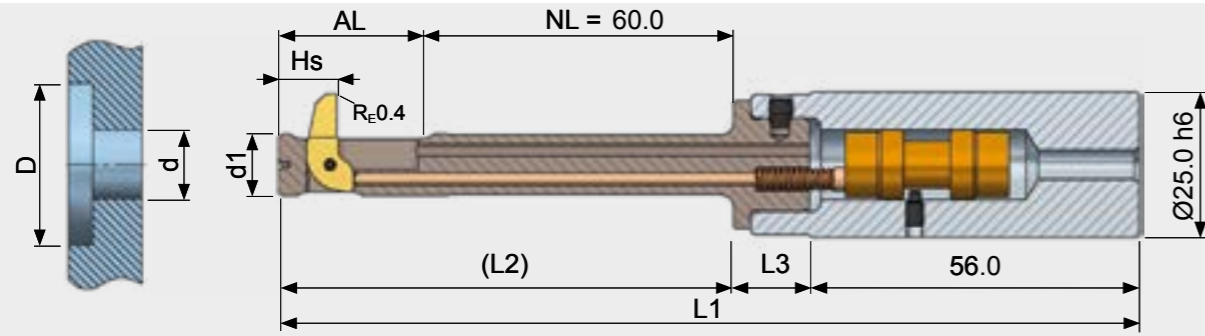

Tool Table

Bore-Ø d	Tool-Ø d1	Counter- bore-Ø D	AL	HS	L1	L2	L3	Tool without Blade		Blade ¹
								Part No.	Part No.	Part No.
12.50	12.40	18.50	26.75	11.40	150.25	80.75	13.50	BSF-E-1250/050-13.5	BSF-M-E-1A-5.0	
		19.00						BSF-E-1250/050-14.0		
		19.50						BSF-E-1250/050-14.5		
		20.00						BSF-E-1250/050-15.0		
		20.50						BSF-E-1250/050-15.5		
		21.00						BSF-E-1250/050-13.5	BSF-M-E-1A-7.5	
		21.50						BSF-E-1250/050-14.0		
		22.00						BSF-E-1250/050-14.5		
		22.50						BSF-E-1250/050-15.0		
		23.00						BSF-E-1250/050-15.5		
		23.50						BSF-E-1250/050-13.5	BSF-M-E-1A-10.0	
		24.00						BSF-E-1250/050-14.0		
		24.50						BSF-E-1250/050-14.5		
		25.00						BSF-E-1250/050-15.0		
25.50	BSF-E-1250/050-15.5									
26.00	BSF-E-1250/050-13.5	BSF-M-E-1A-12.5								
26.50	BSF-E-1250/050-14.0									
27.00	BSF-E-1250/050-14.5									
27.50	BSF-E-1250/050-15.0									
28.00	BSF-E-1250/050-15.5									
28.50	BSF-E-1250/050-13.5	BSF-M-E-1A-15.0								
29.00	BSF-E-1250/050-14.0									

¹A = Coating for steel alloys, titanium and Inconel / D = Coating for aluminium alloys (please see page 136)

ORDERING INFORMATION

- Standard shank for tool part number without any addition: Cylindrical shank.
- With addition: "-HB" = Weldon shank, "-HE" = Whistle Notch shank (please see page 136)
- Attention: The blades for the tool need to be ordered separately.

BSF Tool for Bore-Ø 13.0 mm

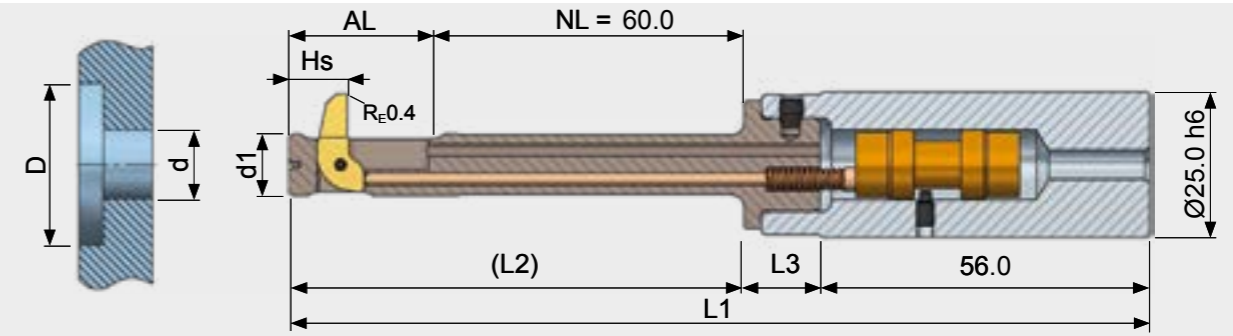

Tool Table

Bore-Ø d	Tool-Ø d1	Counter- bore-Ø D	AL	HS	L1	L2	L3	Tool without Blade		Blade ¹
								Part No.	Part No.	Part No.
13.00	12.90	19.00	26.75	11.40	150.25	80.75	13.50	BSF-E-1300/050-14.0	BSF-M-E-1A-5.0	
		19.50						BSF-E-1300/050-14.5		
		20.00						BSF-E-1300/050-15.0		
		20.50						BSF-E-1300/050-15.5		
		21.00						BSF-E-1300/050-16.0		
		21.50						BSF-E-1300/050-14.0	BSF-M-E-1A-7.5	
		22.00						BSF-E-1300/050-14.5		
		22.50						BSF-E-1300/050-15.0		
		23.00						BSF-E-1300/050-15.5		
		23.50						BSF-E-1300/050-16.0		
		24.00						BSF-E-1300/050-14.0	BSF-M-E-1A-10.0	
		24.50						BSF-E-1300/050-14.5		
		25.00						BSF-E-1300/050-15.0		
		25.50						BSF-E-1300/050-15.5		
		26.00						BSF-E-1300/050-16.0		
26.50	BSF-E-1300/050-14.0	BSF-M-E-1A-12.5								
27.00	BSF-E-1300/050-14.5									
27.50	BSF-E-1300/050-15.0									
28.00	BSF-E-1300/050-15.5									
28.50	BSF-E-1300/050-16.0									
29.00	BSF-E-1300/050-14.0	BSF-M-E-1A-15.0								
29.50	BSF-E-1300/050-14.5									
30.00	BSF-E-1300/050-15.0									

¹A = Coating for steel alloys, titanium and Inconel / D = Coating for aluminium alloys (please see page 136)

ORDERING INFORMATION

- Standard shank for tool part number without any addition: Cylindrical shank.
- With addition: "-HB" = Weldon shank, "-HE" = Whistle Notch shank (please see page 136)
- Attention: The blades for the tool need to be ordered separately.

BSF Tool for Bore-Ø 13.5 mm

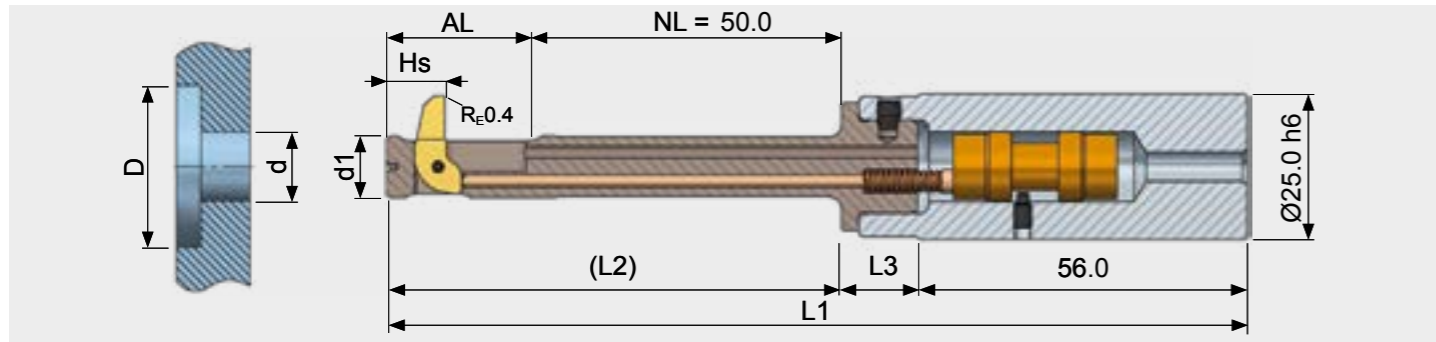

Tool Table

Bore-Ø d	Tool-Ø d1	Counter- bore-Ø D	AL	HS	L1	L2	L3	Tool without Blade	Blade ¹
								Part No.	Part No.
13.50	13.40	19.50	26.75	11.40	150.25	80.75	13.50	BSF-E-1350/050-14.5	BSF-M-E-1A-5.0
		20.00						BSF-E-1350/050-15.0	
		20.50						BSF-E-1350/050-15.5	
		21.00						BSF-E-1350/050-16.0	
		21.50						BSF-E-1350/050-16.5	
	22.00							BSF-E-1350/050-14.5	BSF-M-E-1A-7.5
		22.50						BSF-E-1350/050-15.0	
		23.00						BSF-E-1350/050-15.5	
		23.50						BSF-E-1350/050-16.0	
		24.00						BSF-E-1350/050-16.5	
	24.50							BSF-E-1350/050-14.5	BSF-M-E-1A-10.0
		25.00						BSF-E-1350/050-15.0	
		25.50						BSF-E-1350/050-15.5	
		26.00						BSF-E-1350/050-16.0	
		26.50						BSF-E-1350/050-16.5	
	27.00							BSF-E-1350/050-14.5	BSF-M-E-1A-12.5
		27.50						BSF-E-1350/050-15.0	
		28.00						BSF-E-1350/050-15.5	
		28.50						BSF-E-1350/050-16.0	
		29.00						BSF-E-1350/050-16.5	
29.50							BSF-E-1350/050-14.5	BSF-M-E-1A-15.0	
	30.00						BSF-E-1350/050-15.0		
	30.50						BSF-E-1350/050-15.5		
	31.00						BSF-E-1350/050-16.0		
	31.50						BSF-E-1350/050-16.5		

¹A = Coating for steel alloys, titanium and Inconel / D = Coating for aluminium alloys (please see page 136)

ORDERING INFORMATION

- Standard shank for tool part number without any addition: Cylindrical shank.
- With addition: "-HB" = Weldon shank, "-HE" = Whistle Notch shank (please see page 136)
- Attention: The blades for the tool need to be ordered separately.

BSF Tool for Bore-Ø 14.0 mm

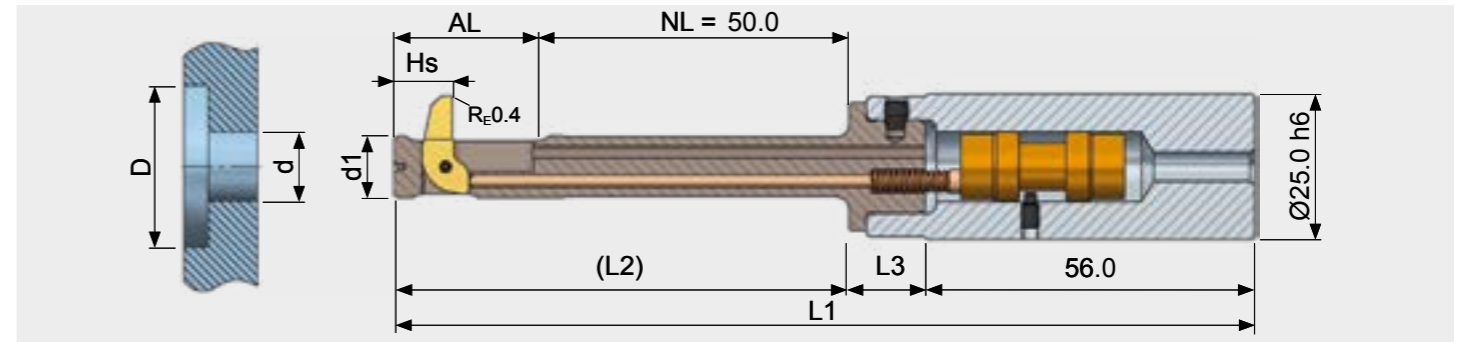

Tool Table

Bore-Ø d	Tool-Ø d1	Counter- bore-Ø D	AL	HS	L1	L2	L3	Tool without Blade	Blade ¹
								Part No.	Part No.
14.00	13.90	20.00	28.00	11.40	151.50	82.00	13.50	BSF-E-1400/050-15.0	BSF-M-E-1A-5.0
		20.50						BSF-E-1400/050-15.5	
		21.00						BSF-E-1400/050-16.0	
		21.50						BSF-E-1400/050-16.5	
		22.00						BSF-E-1400/050-17.0	
	22.50							BSF-E-1400/050-15.0	BSF-M-E-1A-7.5
		23.00						BSF-E-1400/050-15.5	
		23.50						BSF-E-1400/050-16.0	
		24.00						BSF-E-1400/050-16.5	
		24.50						BSF-E-1400/050-17.0	
	25.00							BSF-E-1400/050-15.0	BSF-M-E-1A-10.0
		25.50						BSF-E-1400/050-15.5	
		26.00						BSF-E-1400/050-16.0	
		26.50						BSF-E-1400/050-16.5	
		27.00						BSF-E-1400/050-17.0	
	27.50							BSF-E-1400/050-15.0	BSF-M-E-1A-12.5
		28.00						BSF-E-1400/050-15.5	
		28.50						BSF-E-1400/050-16.0	
		29.00						BSF-E-1400/050-16.5	
		29.50						BSF-E-1400/050-17.0	
30.00							BSF-E-1400/050-15.0	BSF-M-E-1A-15.0	
	30.50						BSF-E-1400/050-15.5		
	31.00						BSF-E-1400/050-16.0		
	31.50						BSF-E-1400/050-16.5		
	32.00						BSF-E-1400/050-17.0		
32.50							BSF-E-1400/050-15.0	BSF-M-E-1A-17.5	

¹A = Coating for steel alloys, titanium and Inconel / D = Coating for aluminium alloys (please see page 136)

ORDERING INFORMATION

- Standard shank for tool part number without any addition: Cylindrical shank.
- With addition: "-HB" = Weldon shank, "-HE" = Whistle Notch shank (please see page 136)
- Attention: The blades for the tool need to be ordered separately.

BSF Tool for Bore-Ø 14.5 mm

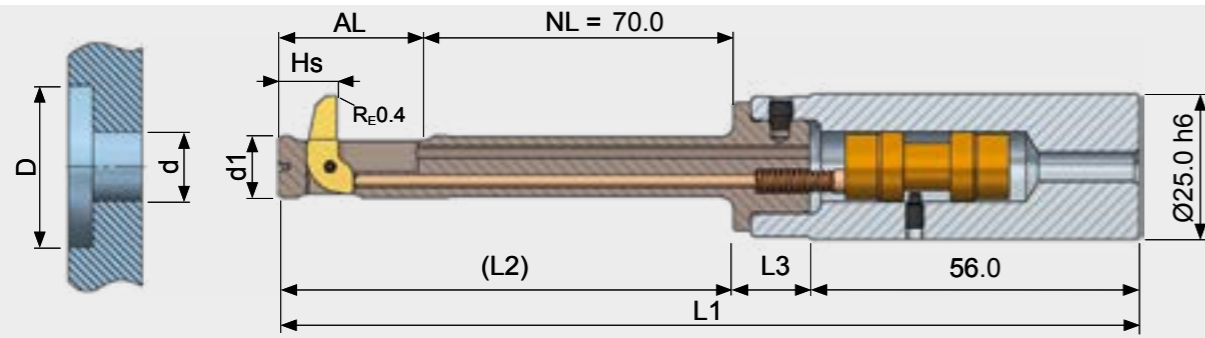

Tool Table

Bore-Ø d	Tool-Ø d1	Counter- bore-Ø D	AL	HS	L1	L2	L3	Tool without Blade		Blade ¹
								Part No.	Part No.	Part No.
14.50	14.40	21.50	30.75	13.40	193.75	104.75	33.00	BSF-F-1450/070-16.0	BSF-M-F-1A-5.5	
								BSF-F-1450/070-16.5		
								BSF-F-1450/070-17.0		
								BSF-F-1450/070-17.5		
								BSF-F-1450/070-18.0		
								BSF-F-1450/070-18.5		
								BSF-F-1450/070-19.0		
								BSF-F-1450/070-16.0	BSF-M-F-1A-9.0	
								BSF-F-1450/070-16.5		
								BSF-F-1450/070-17.0		
								BSF-F-1450/070-17.5		
								BSF-F-1450/070-18.0		
								BSF-F-1450/070-18.5		
								BSF-F-1450/070-19.0		
28.50	29.00	29.50	30.00	30.50	31.00	31.50	32.00	BSF-F-1450/070-16.0	BSF-M-F-1A-12.5	
								BSF-F-1450/070-16.5		
								BSF-F-1450/070-17.0		
								BSF-F-1450/070-17.5		
								BSF-F-1450/070-18.0		
								BSF-F-1450/070-18.5		
								BSF-F-1450/070-19.0		
32.00	32.50	33.00	33.50	34.00	34.50	35.00	35.50	BSF-F-1450/070-16.0	BSF-M-F-1A-16.0	
								BSF-F-1450/070-16.5		
								BSF-F-1450/070-17.0		
								BSF-F-1450/070-17.5		
								BSF-F-1450/070-18.0		

¹A = Coating for steel alloys, titanium and Inconel / D = Coating for aluminium alloys (please see page 136)

ORDERING INFORMATION

- Standard shank for tool part number without any addition: Cylindrical shank.
- With addition: "-HB" = Weldon shank, "-HE" = Whistle Notch shank (please see page 136)
- Attention: The blades for the tool need to be ordered separately.

BSF Tool for Bore-Ø 15.0mm

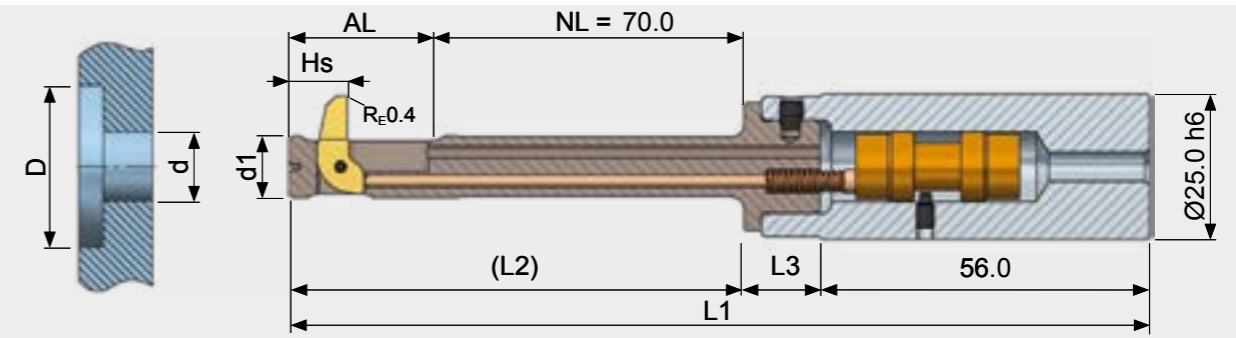

Tool Table

Bore-Ø d	Tool-Ø d1	Counter- bore-Ø D	AL	HS	L1	L2	L3	Tool without Blade		Blade ¹
								Part No.	Part No.	Part No.
15.00	14.90	22.00	30.75	13.40	193.75	104.75	33.00	BSF-F-1500/070-16.5	BSF-M-F-1A-5.5	
								BSF-F-1500/070-17.0		
								BSF-F-1500/070-17.5		
								BSF-F-1500/070-18.0		
								BSF-F-1500/070-18.5		
								BSF-F-1500/070-19.0		
								BSF-F-1500/070-19.5		
								BSF-F-1500/070-16.5	BSF-M-F-1A-9.0	
								BSF-F-1500/070-17.0		
								BSF-F-1500/070-17.5		
								BSF-F-1500/070-18.0		
								BSF-F-1500/070-18.5		
								BSF-F-1500/070-19.0		
								BSF-F-1500/070-19.5		
29.00	29.50	30.00	30.50	31.00	31.50	32.00	32.50	BSF-F-1500/070-16.5	BSF-M-F-1A-12.5	
								BSF-F-1500/070-17.0		
								BSF-F-1500/070-17.5		
								BSF-F-1500/070-18.0		
								BSF-F-1500/070-18.5		
								BSF-F-1500/070-19.0		
								BSF-F-1500/070-19.5		
32.50	33.00	33.50	34.00	34.50	35.00	35.50	36.00	BSF-F-1500/070-16.5	BSF-M-F-1A-16.0	
								BSF-F-1500/070-17.0		
								BSF-F-1500/070-17.5		
								BSF-F-1500/070-18.0		
								BSF-F-1500/070-18.5		

¹A = Coating for steel alloys, titanium and Inconel / D = Coating for aluminium alloys (please see page 136)

ORDERING INFORMATION

- Standard shank for tool part number without any addition: Cylindrical shank.
- With addition: "-HB" = Weldon shank, "-HE" = Whistle Notch shank (please see page 136)
- Attention: The blades for the tool need to be ordered separately.

BSF Tool for Bore-Ø 15.5 mm

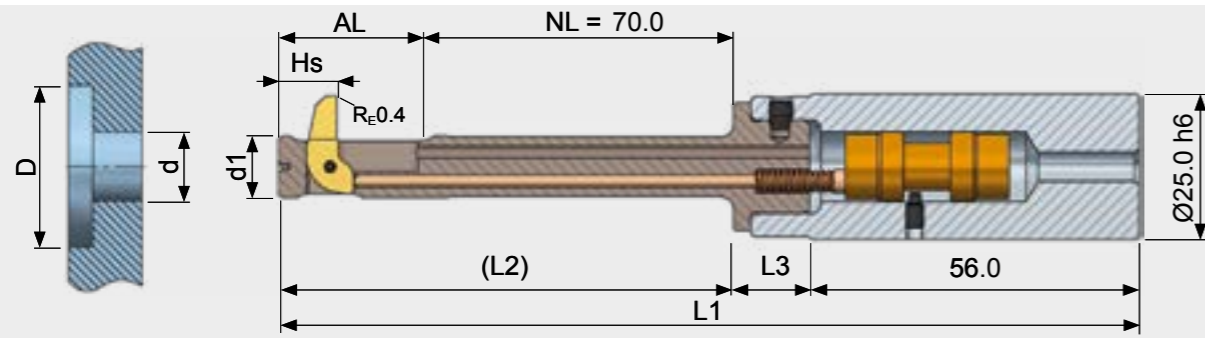

Tool Table

Bore-Ø d	Tool-Ø d1	Counter- bore-Ø D	AL	HS	L1	L2	L3	Tool without Blade		Blade ¹
								Part No.	Part No.	Part No.
15.50	15.40	22.50	30.75	13.40	193.75	104.75	33.00	BSF-F-1550/070-17.0	BSF-M-F-1A-5.5	
								BSF-F-1550/070-17.5		
								BSF-F-1550/070-18.0		
								BSF-F-1550/070-18.5		
								BSF-F-1550/070-19.0		
								BSF-F-1550/070-19.5		
								BSF-F-1550/070-20.0		
								BSF-F-1550/070-17.0	BSF-M-F-1A-9.0	
								BSF-F-1550/070-17.5		
								BSF-F-1550/070-18.0		
								BSF-F-1550/070-18.5		
								BSF-F-1550/070-19.0		
								BSF-F-1550/070-19.5		
								BSF-F-1550/070-20.0		
								BSF-F-1550/070-17.0	BSF-M-F-1A-12.5	
								BSF-F-1550/070-17.5		
								BSF-F-1550/070-18.0		
								BSF-F-1550/070-18.5		
								BSF-F-1550/070-19.0		
								BSF-F-1550/070-19.5		
								BSF-F-1550/070-20.0		
								BSF-F-1550/070-17.0	BSF-M-F-1A-16.0	
								BSF-F-1550/070-17.5		
								BSF-F-1550/070-18.0		
BSF-F-1550/070-18.5										
BSF-F-1550/070-19.0										
BSF-F-1550/070-19.5										
BSF-F-1550/070-20.0										

¹A = Coating for steel alloys, titanium and Inconel / D = Coating for aluminium alloys (please see page 136)

ORDERING INFORMATION

- Standard shank for tool part number without any addition: Cylindrical shank.
- With addition: "-HB" = Weldon shank, "-HE" = Whistle Notch shank (please see page 136)
- Attention: The blades for the tool need to be ordered separately.

BSF Tool for Bore-Ø 16.0 mm

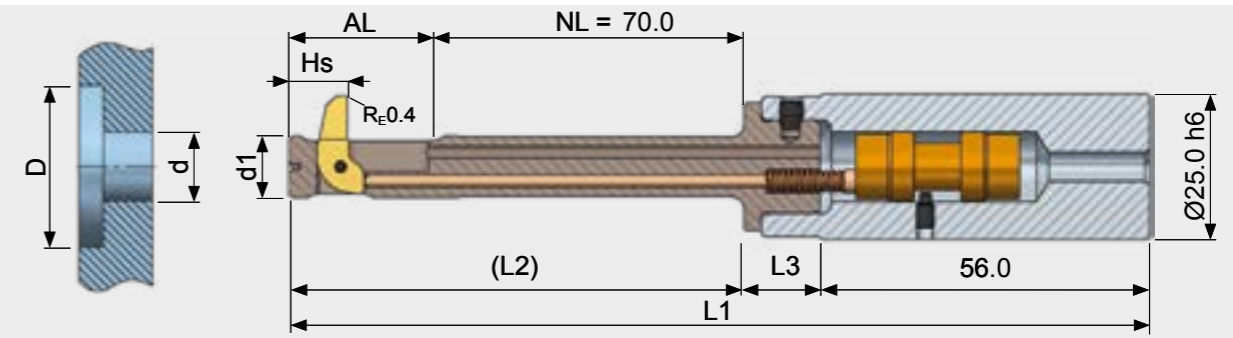

Tool Table

Bore-Ø d	Tool-Ø d1	Counter- bore-Ø D	AL	HS	L1	L2	L3	Tool without Blade		Blade ¹
								Part No.	Part No.	Part No.
16.00	15.90	23.00	32.50	13.40	195.50	106.50	33.00	BSF-F-1600/070-17.5	BSF-M-F-1A-5.5	
								BSF-F-1600/070-18.0		
								BSF-F-1600/070-18.5		
								BSF-F-1600/070-19.0		
								BSF-F-1600/070-19.5		
								BSF-F-1600/070-20.0		
								BSF-F-1600/070-20.5		
								BSF-F-1600/070-17.5	BSF-M-F-1A-9.0	
								BSF-F-1600/070-18.0		
								BSF-F-1600/070-18.5		
								BSF-F-1600/070-19.0		
								BSF-F-1600/070-19.5		
								BSF-F-1600/070-20.0		
								BSF-F-1600/070-20.5		
								BSF-F-1600/070-17.5	BSF-M-F-1A-12.5	
								BSF-F-1600/070-18.0		
								BSF-F-1600/070-18.5		
								BSF-F-1600/070-19.0		
								BSF-F-1600/070-19.5		
								BSF-F-1600/070-20.0		
								BSF-F-1600/070-20.5		
								BSF-F-1600/070-17.5	BSF-M-F-1A-16.0	
								BSF-F-1600/070-18.0		
								BSF-F-1600/070-18.5		
BSF-F-1600/070-19.0										
BSF-F-1600/070-19.5										
BSF-F-1600/070-20.0										
BSF-F-1600/070-20.5										
								BSF-F-1600/070-17.5	BSF-M-F-1A-19.5	

¹A = Coating for steel alloys, titanium and Inconel / D = Coating for aluminium alloys (please see page 136)

ORDERING INFORMATION

- Standard shank for tool part number without any addition: Cylindrical shank.
- With addition: "-HB" = Weldon shank, "-HE" = Whistle Notch shank (please see page 136)
- Attention: The blades for the tool need to be ordered separately.

BSF Tool for Bore-Ø 16.5 mm

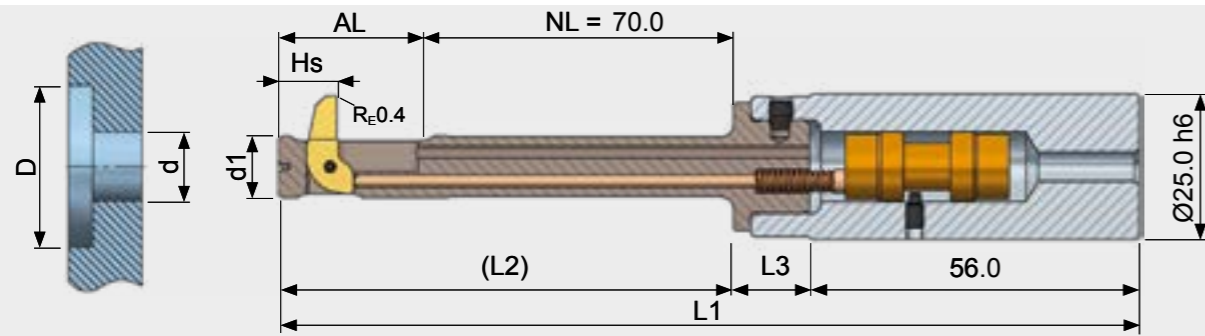

Tool Table

Bore-Ø d	Tool-Ø d1	Counter- bore-Ø D	AL	HS	L1	L2	L3	Tool without Blade		Blade ¹
								Part No.	Part No.	Part No.
16.50	16.40	23.50	32.50	13.40	195.50	106.50	33.00	BSF-F-1650/070-18.0	BSF-M-F-1A-5.5	
								BSF-F-1650/070-18.5		
								BSF-F-1650/070-19.0		
								BSF-F-1650/070-19.5		
								BSF-F-1650/070-20.0		
								BSF-F-1650/070-20.5		
								BSF-F-1650/070-21.0		
								BSF-F-1650/070-18.0	BSF-M-F-1A-9.0	
								BSF-F-1650/070-18.5		
								BSF-F-1650/070-19.0		
								BSF-F-1650/070-19.5		
								BSF-F-1650/070-20.0		
								BSF-F-1650/070-20.5		
								BSF-F-1650/070-21.0		
								BSF-F-1650/070-18.0	BSF-M-F-1A-12.5	
								BSF-F-1650/070-18.5		
								BSF-F-1650/070-19.0		
								BSF-F-1650/070-19.5		
								BSF-F-1650/070-20.0		
								BSF-F-1650/070-20.5		
								BSF-F-1650/070-21.0		
								BSF-F-1650/070-18.0	BSF-M-F-1A-16.0	
								BSF-F-1650/070-18.5		
								BSF-F-1650/070-19.0		
								BSF-F-1650/070-19.5		
								BSF-F-1650/070-20.0		
								BSF-F-1650/070-20.5		
								BSF-F-1650/070-21.0		
								BSF-F-1650/070-18.0	BSF-M-F-1A-19.5	
								BSF-F-1650/070-18.5		

¹A = Coating for steel alloys, titanium and Inconel / D = Coating for aluminium alloys (please see page 136)

ORDERING INFORMATION

- Standard shank for tool part number without any addition: Cylindrical shank.
- With addition: "-HB" = Weldon shank, "-HE" = Whistle Notch shank (please see page 136)
- Attention: The blades for the tool need to be ordered separately.

BSF Tool for Bore-Ø 17.0 mm

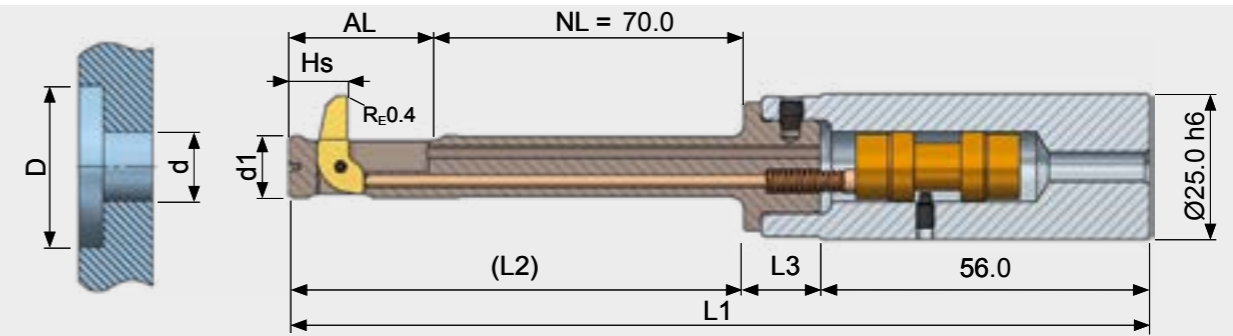

Tool Table

Bore-Ø d	Tool-Ø d1	Counter- bore-Ø D	AL	HS	L1	L2	L3	Tool without Blade		Blade ¹
								Part No.	Part No.	Part No.
17.00	16.90	24.00	32.50	13.40	195.50	106.50	33.00	BSF-F-1700/070-18.5	BSF-M-F-1A-5.5	
								BSF-F-1700/070-19.0		
								BSF-F-1700/070-19.5		
								BSF-F-1700/070-20.0		
								BSF-F-1700/070-20.5		
								BSF-F-1700/070-21.0		
								BSF-F-1700/070-21.5		
								BSF-F-1700/070-18.5	BSF-M-F-1A-9.0	
								BSF-F-1700/070-19.0		
								BSF-F-1700/070-19.5		
								BSF-F-1700/070-20.0		
								BSF-F-1700/070-20.5		
								BSF-F-1700/070-21.0		
								BSF-F-1700/070-21.5		
								BSF-F-1700/070-18.5	BSF-M-F-1A-12.5	
								BSF-F-1700/070-19.0		
								BSF-F-1700/070-19.5		
								BSF-F-1700/070-20.0		
								BSF-F-1700/070-20.5		
								BSF-F-1700/070-21.0		
								BSF-F-1700/070-21.5		
								BSF-F-1700/070-18.5	BSF-M-F-1A-16.0	
								BSF-F-1700/070-19.0		
								BSF-F-1700/070-19.5		
								BSF-F-1700/070-20.0		
								BSF-F-1700/070-20.5		
								BSF-F-1700/070-21.0		
								BSF-F-1700/070-21.5		
								BSF-F-1700/070-18.5	BSF-M-F-1A-19.5	
								BSF-F-1700/070-19.0		
								BSF-F-1700/070-19.5		
								BSF-F-1700/070-20.0		

¹A = Coating for steel alloys, titanium and Inconel / D = Coating for aluminium alloys (please see page 136)

ORDERING INFORMATION

- Standard shank for tool part number without any addition: Cylindrical shank.
- With addition: "-HB" = Weldon shank, "-HE" = Whistle Notch shank (please see page 136)
- Attention: The blades for the tool need to be ordered separately.

BSF Tool for Bore-Ø 17.5 mm

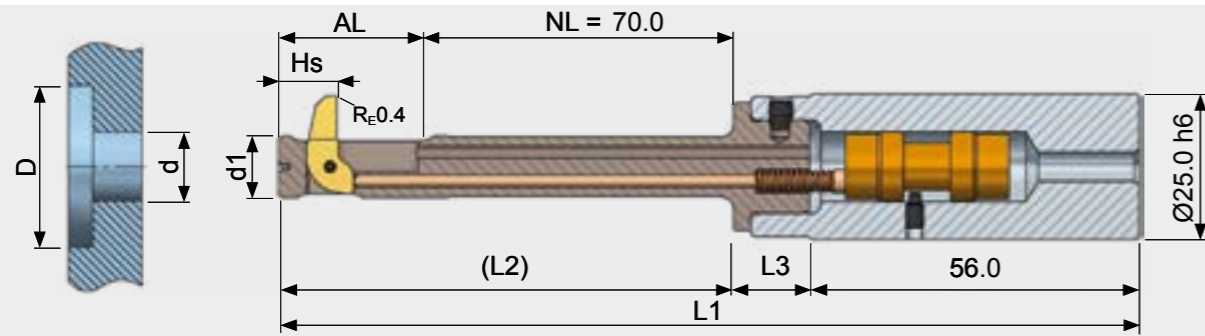

Tool Table

Bore-Ø d	Tool-Ø d1	Counter- bore-Ø D	AL	HS	L1	L2	L3	Tool without Blade		Blade ¹
								Part No.	Part No.	Part No.
17.50	17.40	26.00	37.25	16.30	200.25	111.25	33.00	BSF-G-1750/070-20.0	BSF-M-G-1A-6.0	
		26.50						BSF-G-1750/070-20.5		
		27.00						BSF-G-1750/070-21.0		
		27.50						BSF-G-1750/070-21.5		
		28.00						BSF-G-1750/070-22.0		
		28.50						BSF-G-1750/070-22.5		
		29.00						BSF-G-1750/070-23.0		
		29.50						BSF-G-1750/070-23.5		
		30.00						BSF-G-1750/070-24.0		
		30.50						BSF-G-1750/070-20.0		BSF-M-G-1A-10.5
		31.00	37.25	16.30	200.25	111.25	33.00	BSF-G-1750/070-20.5	BSF-M-G-1A-10.5	
		31.50						BSF-G-1750/070-21.0		
		32.00						BSF-G-1750/070-21.5		
		32.50						BSF-G-1750/070-22.0		
		33.00						BSF-G-1750/070-22.5		
		33.50						BSF-G-1750/070-23.0		
		34.00						BSF-G-1750/070-23.5		
		34.50						BSF-G-1750/070-24.0		
		35.00						BSF-G-1750/070-20.0		BSF-M-G-1A-15.0
		35.50						BSF-G-1750/070-20.5		
		36.00	37.25	16.30	200.25	111.25	33.00	BSF-G-1750/070-21.0	BSF-M-G-1A-15.0	
		36.50						BSF-G-1750/070-21.5		
		37.00						BSF-G-1750/070-22.0		
		37.50						BSF-G-1750/070-22.5		
		38.00						BSF-G-1750/070-23.0		
		38.50						BSF-G-1750/070-23.5		
		39.00						BSF-G-1750/070-24.0		
		39.50						BSF-G-1750/070-20.0		BSF-M-G-1A-19.5
		40.00						BSF-G-1750/070-20.5		
		40.50						BSF-G-1750/070-21.0		

¹A = Coating for steel alloys, titanium and Inconel / D = Coating for aluminium alloys (please see page 136)

ORDERING INFORMATION

- Standard shank for tool part number without any addition: Cylindrical shank.
- With addition: "-HB" = Weldon shank, "-HE" = Whistle Notch shank (please see page 136)
- Attention: The blades for the tool need to be ordered separately.

BSF Tool for Bore-Ø 18.0 mm

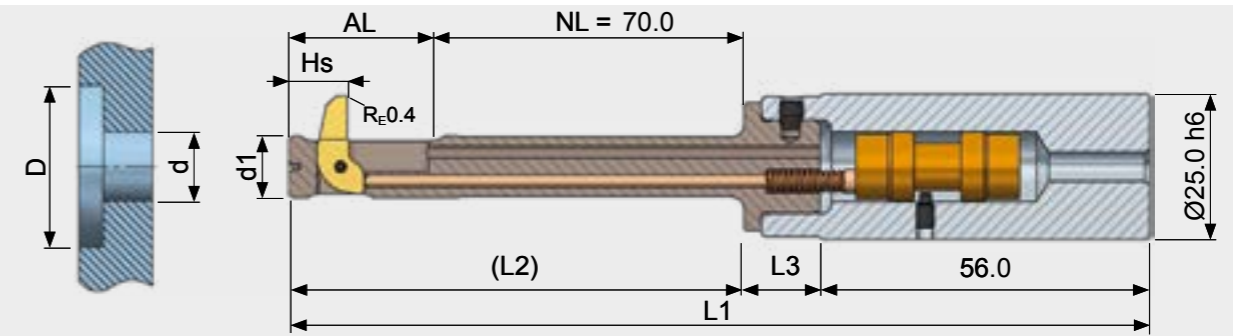

Tool Table

Bore-Ø d	Tool-Ø d1	Counter- bore-Ø D	AL	HS	L1	L2	L3	Tool without Blade		Blade ¹
								Part No.	Part No.	Part No.
18.00	17.90	26.50	37.25	16.30	200.25	111.25	33.00	BSF-G-1800/070-20.5	BSF-M-G-1A-6.0	
		27.00						BSF-G-1800/070-21.0		
		27.50						BSF-G-1800/070-21.5		
		28.00						BSF-G-1800/070-22.0		
		28.50						BSF-G-1800/070-22.5		
		29.00						BSF-G-1800/070-23.0		
		29.50						BSF-G-1800/070-23.5		
		30.00						BSF-G-1800/070-24.0		
		30.50						BSF-G-1800/070-24.5		
		31.00						BSF-G-1800/070-20.5		BSF-M-G-1A-10.5
		31.50	37.25	16.30	200.25	111.25	33.00	BSF-G-1800/070-21.0	BSF-M-G-1A-10.5	
		32.00						BSF-G-1800/070-21.5		
		32.50						BSF-G-1800/070-22.0		
		33.00						BSF-G-1800/070-22.5		
		33.50						BSF-G-1800/070-23.0		
		34.00						BSF-G-1800/070-23.5		
		34.50						BSF-G-1800/070-24.0		
		35.00						BSF-G-1800/070-24.5		
		35.50						BSF-G-1800/070-20.5		BSF-M-G-1A-15.0
		36.00						BSF-G-1800/070-21.0		
		36.50	37.25	16.30	200.25	111.25	33.00	BSF-G-1800/070-21.5	BSF-M-G-1A-15.0	
		37.00						BSF-G-1800/070-22.0		
		37.50						BSF-G-1800/070-22.5		
		38.00						BSF-G-1800/070-23.0		
		38.50						BSF-G-1800/070-23.5		
		39.00						BSF-G-1800/070-24.0		
		39.50						BSF-G-1800/070-24.5		
		40.00						BSF-G-1800/070-20.5		BSF-M-G-1A-19.5
		40.50						BSF-G-1800/070-21.0		
		41.00						BSF-G-1800/070-21.5		
41.50	BSF-G-1800/070-22.0									

¹A = Coating for steel alloys, titanium and Inconel / D = Coating for aluminium alloys (please see page 136)

ORDERING INFORMATION

- Standard shank for tool part number without any addition: Cylindrical shank.
- With addition: "-HB" = Weldon shank, "-HE" = Whistle Notch shank (please see page 136)
- Attention: The blades for the tool need to be ordered separately.

BSF Tool for Bore-Ø 18.5 mm

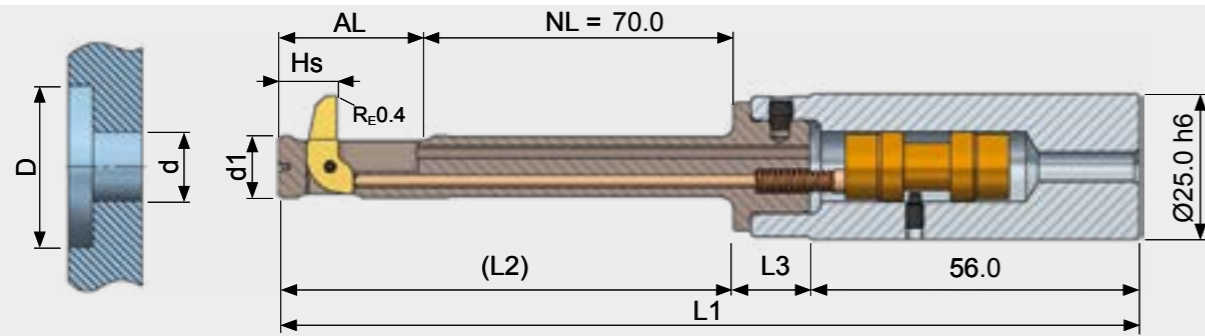

Tool Table

Bore-Ø d	Tool-Ø d1	Counter- bore-Ø D	AL	HS	L1	L2	L3	Tool without Blade		Blade ¹
								Part No.	Part No.	Part No.
18.50	18.40	27.00	37.25	16.30	200.25	111.25	33.00	BSF-G-1850/070-21.0	BSF-M-G-1A-6.0	
								BSF-G-1850/070-21.5		
								BSF-G-1850/070-22.0		
								BSF-G-1850/070-22.5		
								BSF-G-1850/070-23.0		
								BSF-G-1850/070-23.5		
								BSF-G-1850/070-24.0		
								BSF-G-1850/070-24.5		
								BSF-G-1850/070-25.0		
								BSF-G-1850/070-21.0	BSF-M-G-1A-10.5	
								BSF-G-1850/070-21.5		
								BSF-G-1850/070-22.0		
								BSF-G-1850/070-22.5		
								BSF-G-1850/070-23.0		
								BSF-G-1850/070-23.5		
								BSF-G-1850/070-24.0		
								BSF-G-1850/070-24.5		
								BSF-G-1850/070-25.0		
								BSF-G-1850/070-21.0	BSF-M-G-1A-15.0	
								BSF-G-1850/070-21.5		
BSF-G-1850/070-22.0										
BSF-G-1850/070-22.5										
BSF-G-1850/070-23.0										
BSF-G-1850/070-23.5										
BSF-G-1850/070-24.0										
BSF-G-1850/070-24.5										
BSF-G-1850/070-25.0										
BSF-G-1850/070-21.0	BSF-M-G-1A-19.5									
BSF-G-1850/070-21.5										
BSF-G-1850/070-22.0										
BSF-G-1850/070-22.5										
BSF-G-1850/070-23.0										
BSF-G-1850/070-23.5										

¹A = Coating for steel alloys, titanium and Inconel / D = Coating for aluminium alloys (please see page 136)

ORDERING INFORMATION

- Standard shank for tool part number without any addition: Cylindrical shank.
- With addition: "-HB" = Weldon shank, "-HE" = Whistle Notch shank (please see page 136)
- Attention: The blades for the tool need to be ordered separately.

BSF Tool for Bore-Ø 19.0 mm

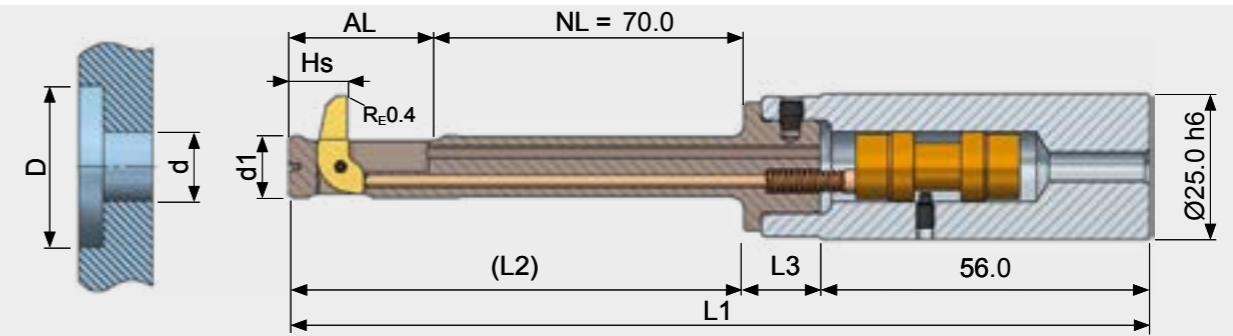

Tool Table

Bore-Ø d	Tool-Ø d1	Counter- bore-Ø D	AL	HS	L1	L2	L3	Tool without Blade		Blade ¹
								Part No.	Part No.	Part No.
19.00	18.90	27.50	37.25	16.30	200.25	111.25	33.00	BSF-G-1900/070-21.5	BSF-M-G-1A-6.0	
								BSF-G-1900/070-22.0		
								BSF-G-1900/070-22.5		
								BSF-G-1900/070-23.0		
								BSF-G-1900/070-23.5		
								BSF-G-1900/070-24.0		
								BSF-G-1900/070-24.5		
								BSF-G-1900/070-25.0		
								BSF-G-1900/070-25.5		
								BSF-G-1900/070-21.5	BSF-M-G-1A-10.5	
								BSF-G-1900/070-22.0		
								BSF-G-1900/070-22.5		
								BSF-G-1900/070-23.0		
								BSF-G-1900/070-23.5		
								BSF-G-1900/070-24.0		
								BSF-G-1900/070-24.5		
								BSF-G-1900/070-25.0		
								BSF-G-1900/070-25.5		
								BSF-G-1900/070-21.5	BSF-M-G-1A-15.0	
								BSF-G-1900/070-22.0		
BSF-G-1900/070-22.5										
BSF-G-1900/070-23.0										
BSF-G-1900/070-23.5										
BSF-G-1900/070-24.0										
BSF-G-1900/070-24.5										
BSF-G-1900/070-25.0										
BSF-G-1900/070-25.5										
BSF-G-1900/070-21.5	BSF-M-G-1A-19.5									
BSF-G-1900/070-22.0										
BSF-G-1900/070-22.5										
BSF-G-1900/070-23.0										
BSF-G-1900/070-23.5										
BSF-G-1900/070-24.0										
BSF-G-1900/070-24.5										

¹A = Coating for steel alloys, titanium and Inconel / D = Coating for aluminium alloys (please see page 136)

ORDERING INFORMATION

- Standard shank for tool part number without any addition: Cylindrical shank.
- With addition: "-HB" = Weldon shank, "-HE" = Whistle Notch shank (please see page 136)
- Attention: The blades for the tool need to be ordered separately.

BSF Tool for Bore-Ø 19.5 mm

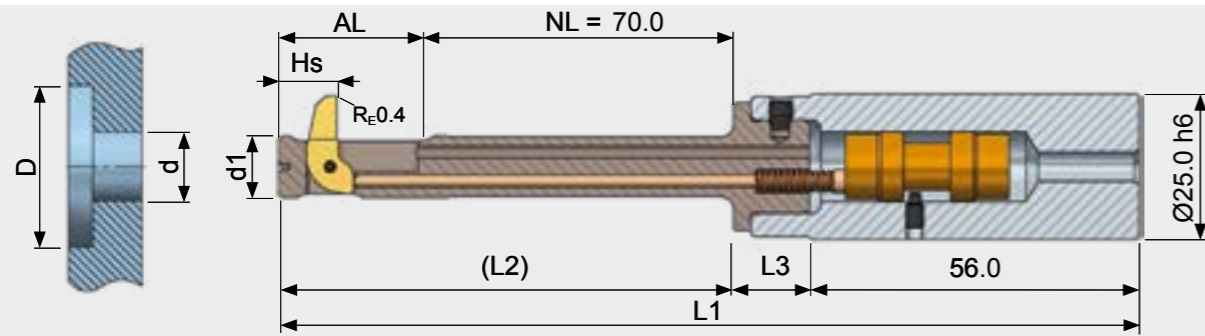

Tool Table

Bore-Ø d	Tool-Ø d1	Counter- bore-Ø D	AL	HS	L1	L2	L3	Tool without Blade		Blade ¹
								Part No.	Part No.	Part No.
19.50	19.40	28.00	37.25	16.30	200.25	111.25	33.00	BSF-G-1950/070-22.0	BSF-M-G-1A-6.0	
								BSF-G-1950/070-22.5		
								BSF-G-1950/070-23.0		
								BSF-G-1950/070-23.5		
								BSF-G-1950/070-24.0		
								BSF-G-1950/070-24.5		
								BSF-G-1950/070-25.0		
								BSF-G-1950/070-25.5		
								BSF-G-1950/070-26.0		
								BSF-G-1950/070-22.0	BSF-M-G-1A-10.5	
								BSF-G-1950/070-22.5		
								BSF-G-1950/070-23.0		
								BSF-G-1950/070-23.5		
								BSF-G-1950/070-24.0		
								BSF-G-1950/070-24.5		
								BSF-G-1950/070-25.0		
								BSF-G-1950/070-25.5		
								BSF-G-1950/070-26.0		
								19.50	19.40	28.00
BSF-G-1950/070-22.5										
BSF-G-1950/070-23.0										
BSF-G-1950/070-23.5										
BSF-G-1950/070-24.0										
BSF-G-1950/070-24.5										
BSF-G-1950/070-25.0										
BSF-G-1950/070-25.5										
BSF-G-1950/070-26.0										
BSF-G-1950/070-22.0	BSF-M-G-1A-19.5									
BSF-G-1950/070-22.5										
BSF-G-1950/070-23.0										
BSF-G-1950/070-23.5										
BSF-G-1950/070-24.0										
BSF-G-1950/070-24.5										
BSF-G-1950/070-25.0										
BSF-G-1950/070-25.5										

¹A = Coating for steel alloys, titanium and Inconel / D = Coating for aluminium alloys (please see page 136)

ORDERING INFORMATION:

- Standard shank for tool part number without any addition: Cylindrical shank. With addition: "-HB" = Weldon shank, "-HE" = Whistle Notch shank (please s. page 136) - Attention: The blades for the tool need to be ordered separately.

BSF Tool for Bore-Ø 20.0 mm

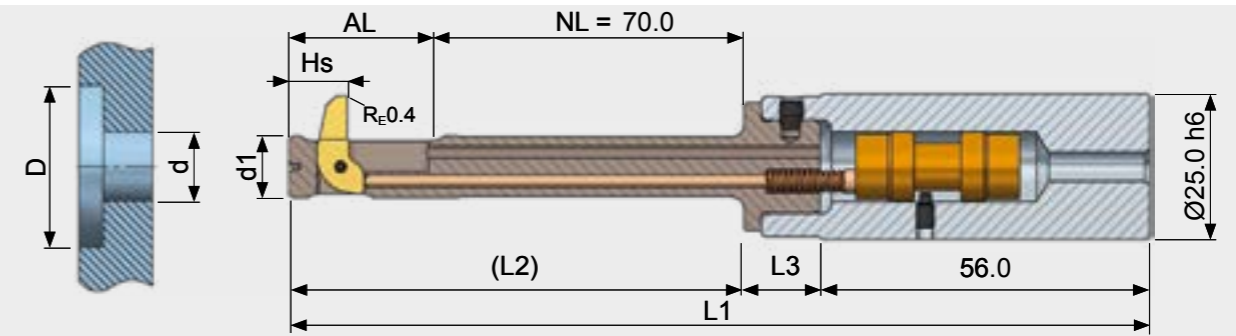

Tool Table

Bore-Ø d	Tool-Ø d1	Counter- bore-Ø D	AL	HS	L1	L2	L3	Tool without Blade		Blade ¹								
								Part No.	Part No.	Part No.								
20.00	19.90	28.50	37.25	16.30	200.25	111.25	33.00	BSF-G-2000/070-22.5	BSF-M-G-1A-6.0									
								BSF-G-2000/070-23.0										
								BSF-G-2000/070-23.5										
								BSF-G-2000/070-24.0										
								BSF-G-2000/070-24.5										
								BSF-G-2000/070-25.0										
								BSF-G-2000/070-25.5										
								BSF-G-2000/070-26.0										
								BSF-G-2000/070-26.5										
								BSF-G-2000/070-22.5	BSF-M-G-1A-10.5									
								BSF-G-2000/070-23.0										
								BSF-G-2000/070-23.5										
								BSF-G-2000/070-24.0										
								BSF-G-2000/070-24.5										
								BSF-G-2000/070-25.0										
								BSF-G-2000/070-25.5										
								BSF-G-2000/070-26.0										
								BSF-G-2000/070-26.5										
								20.00	19.90	28.50	37.25	16.30	200.25	111.25	33.00	BSF-G-2000/070-22.5	BSF-M-G-1A-15.0	
																BSF-G-2000/070-23.0		
BSF-G-2000/070-23.5																		
BSF-G-2000/070-24.0																		
BSF-G-2000/070-24.5																		
BSF-G-2000/070-25.0																		
BSF-G-2000/070-25.5																		
BSF-G-2000/070-26.0																		
BSF-G-2000/070-26.5																		
BSF-G-2000/070-22.5	BSF-M-G-1A-19.5																	
BSF-G-2000/070-23.0																		
BSF-G-2000/070-23.5																		
BSF-G-2000/070-24.0																		
BSF-G-2000/070-24.5																		
BSF-G-2000/070-25.0																		
BSF-G-2000/070-25.5																		
BSF-G-2000/070-26.0																		
BSF-G-2000/070-26.5																		

¹A = Coating for steel alloys, titanium and Inconel / D = Coating for aluminium alloys (please see page 136)

ORDERING INFORMATION:

- Standard shank for tool part number without any addition: Cylindrical shank. With addition: "-HB" = Weldon shank, "-HE" = Whistle Notch shank (please s. page 136). - Attention: The blades for the tool need to be ordered separately.

BSF Tool for Bore-Ø 20.5 mm

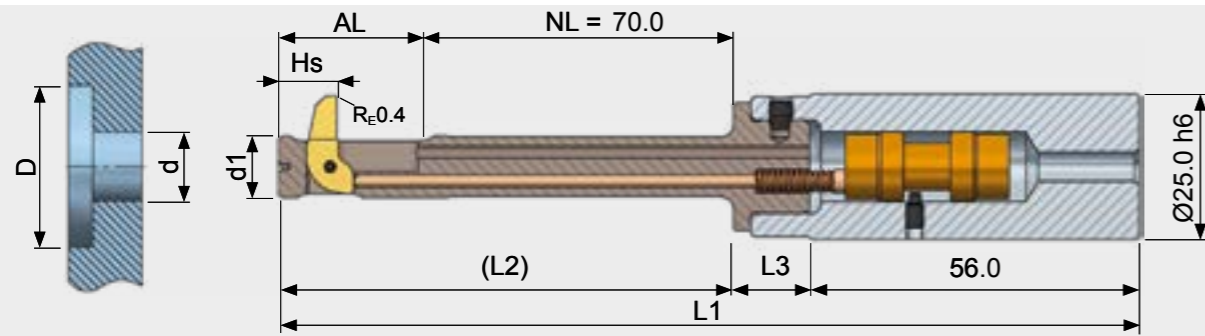

Tool Table

Bore-Ø d	Tool-Ø d1	Counter- bore-Ø D	AL	HS	L1	L2	L3	Tool without Blade		Blade ¹
								Part No.	Part No.	Part No.
20.50	20.40	29.00	39.50	16.30	202.50	113.50	33.00	BSF-G-2050/070-23.0		BSF-M-G-1A-6.0
								BSF-G-2050/070-23.5		
								BSF-G-2050/070-24.0		
								BSF-G-2050/070-24.5		
								BSF-G-2050/070-25.0		
								BSF-G-2050/070-25.5		
								BSF-G-2050/070-26.0		
								BSF-G-2050/070-26.5		
								BSF-G-2050/070-27.0		
								BSF-G-2050/070-23.0		BSF-M-G-1A-10.5
								BSF-G-2050/070-23.5		
								BSF-G-2050/070-24.0		
								BSF-G-2050/070-24.5		
								BSF-G-2050/070-25.0		
								BSF-G-2050/070-25.5		
								BSF-G-2050/070-26.0		
								BSF-G-2050/070-26.5		
								BSF-G-2050/070-27.0		
								BSF-G-2050/070-23.0		BSF-M-G-1A-15.0
								BSF-G-2050/070-23.5		
BSF-G-2050/070-24.0										
BSF-G-2050/070-24.5										
BSF-G-2050/070-25.0										
BSF-G-2050/070-25.5										
BSF-G-2050/070-26.0										
BSF-G-2050/070-26.5										
BSF-G-2050/070-27.0										

¹A = Coating for steel alloys, titanium and Inconel / D = Coating for aluminium alloys (please see page 136)

ORDERING INFORMATION

- Standard shank for tool part number without any addition: Cylindrical shank.
- With addition: "-HB" = Weldon shank, "-HE" = Whistle Notch shank (please see page 136)
- Attention: The blades for the tool need to be ordered separately.

BSF Tool for Bore-Ø 20.5 mm

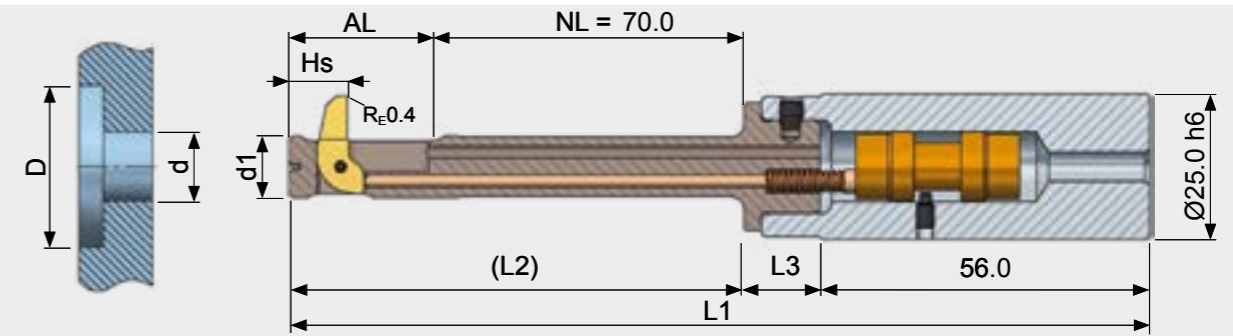

Tool Table

Bore-Ø d	Tool-Ø d1	Counter- bore-Ø D	AL	HS	L1	L2	L3	Tool without Blade		Blade ¹					
								Part No.	Part No.	Part No.					
20.50	20.40	42.50						BSF-G-2050/070-23.0		BSF-M-G-1A-19.5					
								BSF-G-2050/070-23.5							
								BSF-G-2050/070-24.0							
								BSF-G-2050/070-24.5							
								BSF-G-2050/070-25.0							
								BSF-G-2050/070-25.5							
								BSF-G-2050/070-26.0							
								BSF-G-2050/070-26.5							
								BSF-G-2050/070-27.0							
								BSF-G-2050/070-23.0	39.50	16.30	202.50	113.50	33.00	BSF-G-2050/070-23.0	BSF-M-G-1A-24.0
								BSF-G-2050/070-23.5						BSF-G-2050/070-23.5	

¹A = Coating for steel alloys, titanium and Inconel / D = Coating for aluminium alloys (please see page 136)

ORDERING INFORMATION

- Standard shank for tool part number without any addition: Cylindrical shank.
- With addition: "-HB" = Weldon shank, "-HE" = Whistle Notch shank (please see page 136)
- Attention: The blades for the tool need to be ordered separately.

BSF Tool for Bore-Ø 21.0 mm

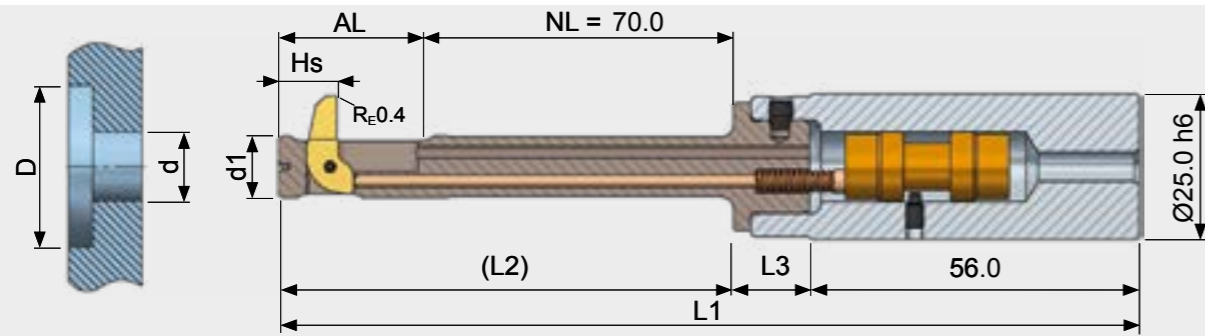

Tool Table

Bore-Ø d	Tool-Ø d1	Counter- bore-Ø D	AL	HS	L1	L2	L3	Tool without Blade	Blade ¹
								Part No.	Part No.
21.00	20.90	29.50	39.50	16.30	202.50	113.50	33.00	BSF-G-2100/070-23.5	BSF-M-G-1A-6.0
		30.00						BSF-G-2100/070-24.0	
		30.50						BSF-G-2100/070-24.5	
		31.00						BSF-G-2100/070-25.0	
		31.50						BSF-G-2100/070-25.5	
		32.00						BSF-G-2100/070-26.0	
		32.50						BSF-G-2100/070-26.5	
		33.00						BSF-G-2100/070-27.0	
		33.50						BSF-G-2100/070-27.5	
		34.00						BSF-G-2100/070-23.5	BSF-M-G-1A-10.5
		34.50						BSF-G-2100/070-24.0	
		35.00						BSF-G-2100/070-24.5	
		35.50						BSF-G-2100/070-25.0	
		36.00						BSF-G-2100/070-25.5	
		36.50						BSF-G-2100/070-26.0	
		37.00						BSF-G-2100/070-26.5	
		37.50						BSF-G-2100/070-27.0	
		38.00						BSF-G-2100/070-27.5	
		38.50						BSF-G-2100/070-23.5	BSF-M-G-1A-15.0
		39.00						BSF-G-2100/070-24.0	
39.50						BSF-G-2100/070-24.5			
40.00						BSF-G-2100/070-25.0			
40.50						BSF-G-2100/070-25.5			
41.00						BSF-G-2100/070-26.0			
41.50						BSF-G-2100/070-26.5			
42.00						BSF-G-2100/070-27.0			
42.50						BSF-G-2100/070-27.5			

¹A = Coating for steel alloys, titanium and Inconel / D = Coating for aluminium alloys (please see page 136)

ORDERING INFORMATION

- Standard shank for tool part number without any addition: Cylindrical shank.
- With addition: "-HB" = Weldon shank, "-HE" = Whistle Notch shank (please see page 136)
- Attention: The blades for the tool need to be ordered separately.

BSF Tool for Bore-Ø 21.0 mm

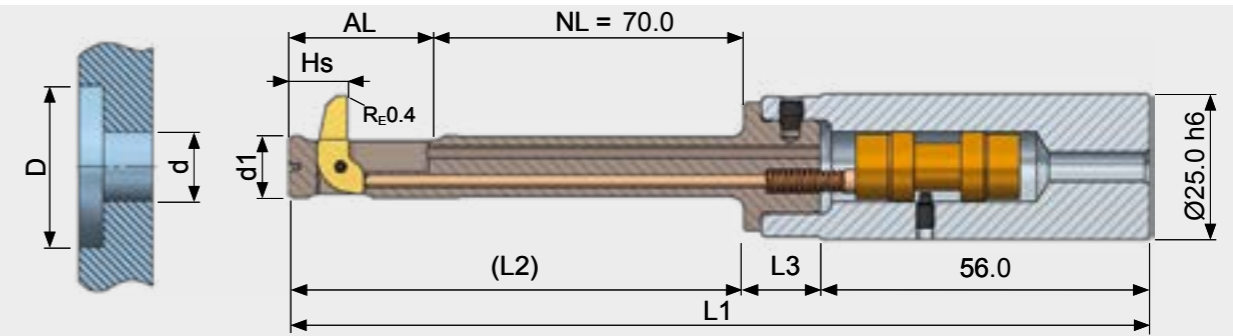

Tool Table

Bore-Ø d	Tool-Ø d1	Counter- bore-Ø D	AL	HS	L1	L2	L3	Tool without Blade	Blade ¹
								Part No.	Part No.
21.00	20.90	43.00	39.50	16.30	202.50	113.50	33.00	BSF-G-2100/070-23.5	BSF-M-G-1A-19.5
		43.50						BSF-G-2100/070-24.0	
		44.00						BSF-G-2100/070-24.5	
		44.50						BSF-G-2100/070-25.0	
		45.00						BSF-G-2100/070-25.5	
		45.50						BSF-G-2100/070-26.0	
		46.00						BSF-G-2100/070-26.5	
		46.50						BSF-G-2100/070-27.0	
		47.00						BSF-G-2100/070-27.5	
		47.50						BSF-G-2100/070-23.5	BSF-M-G-1A-24.0
		48.00						BSF-G-2100/070-24.0	
		48.50						BSF-G-2100/070-24.5	
		49.00						BSF-G-2100/070-25.0	

¹A = Coating for steel alloys, titanium and Inconel / D = Coating for aluminium alloys (please see page 136)

ORDERING INFORMATION

- Standard shank for tool part number without any addition: Cylindrical shank.
- With addition: "-HB" = Weldon shank, "-HE" = Whistle Notch shank (please see page 136)
- Attention: The blades for the tool need to be ordered separately.

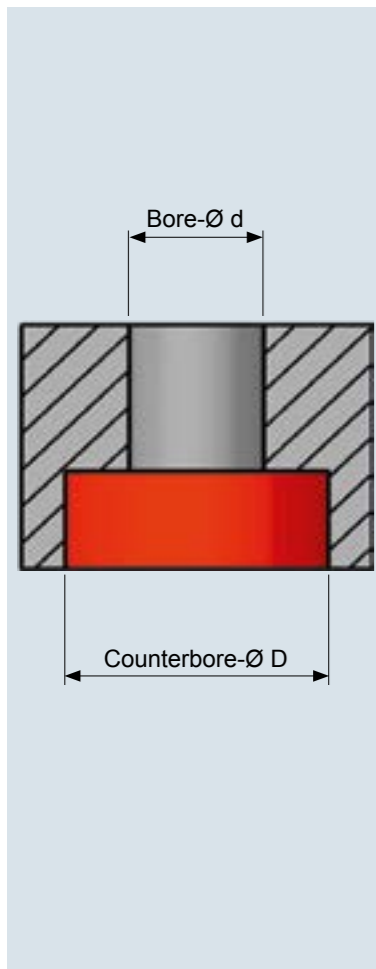

Bore-Ø d	Counterbore-Ø D			
6.5		11.0	13.0	15.0
	Tool	BSF-A-0650/040-6.5	BSF-A-0650/040-7.0	BSF-A-0650/040-7.5
	Blade	BSF-M-A-1A-4.5	BSF-M-A-1A-6.0	BSF-M-A-1A-7.5
8.5		15.0	16.0	18.0
	Tool	BSF-B-0850/040-8.5	BSF-B-0850/040-9.5	BSF-B-0850/040-8.5
	Blade	BSF-M-B-1A-6.5	BSF-M-B-1A-6.5	BSF-M-B-1A-9.5
10.5		18.0	20.0	24.0
	Tool	BSF-D-1050/050-11.0	BSF-D-1050/050-13.0	BSF-D-1050/050-12.0
	Blade	BSF-M-D-1A-7.0	BSF-M-D-1A-7.0	BSF-M-D-1A-12.0
13.0		20.0	24.0	26.0
	Tool	BSF-E-1300/050-15.0	BSF-E-1300/050-14.0	BSF-E-1300/050-16.0
	Blade	BSF-M-E-1A-5.0	BSF-M-E-1A-10.0	BSF-M-E-1A-10.0
17.0		26.0	30.0	33.0
	Tool	BSF-F-1700/070-20.5	BSF-F-1700/070-21.0	BSF-F-1700/070-20.5
	Blade	BSF-M-F-1A-5.5	BSF-M-F-1A-9.0	BSF-M-F-1A-12.5
21.0		33.0	36.0	40.0
	Tool	BSF-G-2100/070-27.0	BSF-G-2100/070-25.5	BSF-G-2100/070-25.0
	Blade	BSF-M-G-1A-6.0	BSF-M-G-1A-10.5	BSF-M-G-1A-15.0

Machine Parameters - Minimum Requirements

Machine	Tool holder with internal cooling Clamping system Weldon without extra sealing option possible Activation speed to swing out the blade: up to 5000 rev./min. The activation speed depends on bore diameter and counterbore ratio. Please refer to page 168 for accurate indications.
Coolant system	Internal coolant through spindle center, minimum 20 bar Activation pressure: 20-50 bar Activation by air: Should the tool solely be useable with air or microlubrication activation, please contact HEULE. Working pressure: 20-40 bar Attention: When machining soft materials, reduce internal coolant pressure! Coolant programmable (on/off) Coolant must be filtered (filter dimension ≤ 25 µm) Coolant emulsion or equivalent coolant
Clamping workpiece	The BSF tool is a pull operating tool. Make sure that there is enough space behind the workpiece for the chips. When machining long chipping materials, program the feed cycle so that you get short chips. The removal of the chips is supported by the coolant flushing.
Clamping system	When using tools with a cylindrical shank, a clamping collet seal is compulsory.

Technical Data and Settings

Cutting Data BSF

Material	Condition	Tensile strength (N/mm ²)	Cutting speed (m/min.)	Series and Bore diameter				
				A	B	C	D	E/F/G
				6.50-7.00	7.50-8.50	9.00-10.00	10.50-11.50	12.00-21.00
				Feed F (mm/rev.)				
Unalloyed steel		<500	40-70	0.01-0.02	0.01-0.03	0.02-0.04	0.03-0.06	0.03-0.08
Cast steel		500-800	40-70	0.01-0.02	0.01-0.03	0.02-0.04	0.03-0.06	0.03-0.08
Grey cast iron		<500	50-90	0.01-0.02	0.01-0.03	0.02-0.04	0.03-0.06	0.03-0.08
Ductile cast iron		300-800	40-70	0.01-0.02	0.01-0.03	0.02-0.04	0.03-0.06	0.03-0.08
Low alloy steel	annealed	<850	40-70	0.01-0.02	0.01-0.03	0.02-0.04	0.03-0.06	0.03-0.08
	tempered	850-1000	30-50	0.01-0.02	0.01-0.03	0.02-0.04	0.03-0.06	0.03-0.08
	tempered	1000-1200	15-30	0.01-0.02	0.01-0.02	0.01-0.03	0.02-0.04	0.02-0.05
High alloy steel	annealed	<850	20-50	0.01-0.02	0.01-0.03	0.02-0.04	0.03-0.06	0.03-0.08
	tempered	850-1100	15-30	0.01-0.02	0.01-0.02	0.01-0.03	0.02-0.04	0.02-0.05
Stainless steel	ferritic	450-650	15-30	0.01-0.02	0.01-0.03	0.02-0.04	0.03-0.06	0.03-0.08
	austenitic	650-900	10-20	0.01-0.02	0.01-0.02	0.01-0.03	0.02-0.04	0.02-0.05
	martensitic	500-700	15-30	0.01-0.02	0.01-0.02	0.01-0.03	0.02-0.04	0.02-0.05
Special alloy	(Inconel, Titan)	<1200	10-20	0.01-0.02	0.01-0.02	0.01-0.03	0.02-0.04	0.02-0.05
Wrought / Cast aluminium alloys		60-120	60-120	0.02-0.03	0.02-0.04	0.02-0.05	0.02-0.08	0.05-0.10
Copper alloys	Brass		50-90	0.01-0.02	0.01-0.03	0.02-0.04	0.03-0.06	0.03-0.08
	Bronze short-chipping		30-50	0.01-0.02	0.01-0.03	0.02-0.04	0.03-0.06	0.03-0.08
	Bronze long-chipping		20-30	0.01-0.02	0.01-0.02	0.01-0.03	0.02-0.04	0.02-0.05

WARNING NOTICE

All listed cutting data are standard values only! The cutting values depend on the amount of slope of the uneven bore edge. (i.e. high slope ► low cutting value). The feed also depends on the sloping ratio. In case of hard to machine materials or uneven bore edges, we recommend to apply cutting speeds that are at the lower end of the range for uneven bore edges.

Activation Speed

The activation speed (rev./min.) to be set to swing out the blade depends on the bore diameter and the counterbore ratio (counterbore diameter : bore diameter).

Counterbore ratio	1.4	1.5	1.6	1.7	1.8	1.9	2.0	2.1	2.2	2.3
Bore-Ø d										
Series A										
6.5	4500	4500	4500	3500	3500	3500	3000	3000	2500	2500
7.0	2500	2500	2500	2500	2500	2000	2000	2000	2000	2000
Series B										
7.5	4500	4500	4500	3500	3500	3000	3000	2500	2500	2500
8.0	2500	2500	2500	2500	2500	2000	2000	2000	2000	2000
8.5	2000	2000	2000	2000	2000	2000	2000	2000	1500	1500
Series C										
9.0	3500	3500	3500	3000	3000	2500	2500	2500	2500	2500
9.5	2500	2500	2500	2500	2000	2000	2000	2000	2000	2000
10.0	2000	2000	2000	2000	2000	2000	2000	2000	2000	1500
Series D										
10.5	5000	5000	5000	3500	3500	3500	3000	3000	2500	2500
11.0	3000	3000	3000	2500	2500	2500	2500	2500	2000	2000
11.5	2500	2500	2500	2000	2000	2000	2000	2000	2000	2000
Series E										
12.0	3500	3500	3500	2500	2500	2500	2500	2500	2000	2000
12.5 - 13.0	2500	2500	2500	2000	2000	2000	2000	1500	1500	1500
13.5 - 14.0	1500	1500	1500	1500	1500	1500	1500	1500	1500	1500
Series F										
14.5	3500	3500	3500	2500	2500	2500	2500	2500	2500	2000
15.0 - 15.5	3000	3000	3000	2500	2500	2500	2000	2000	2000	2000
16.0 - 17.0	2000	2000	2000	1500	1500	1500	1500	1500	1500	1500
Series G										
17.5 - 18.0	3500	3500	3500	2500	2500	2500	2000	2000	2000	1500
18.5 - 19.5	2000	2000	2000	1500	1500	1500	1500	1500	1500	1500
20.0 - 21.0	1500	1500	1500	1000	1000	1000	1000	1000	1000	1000

Drawing Application Parameters

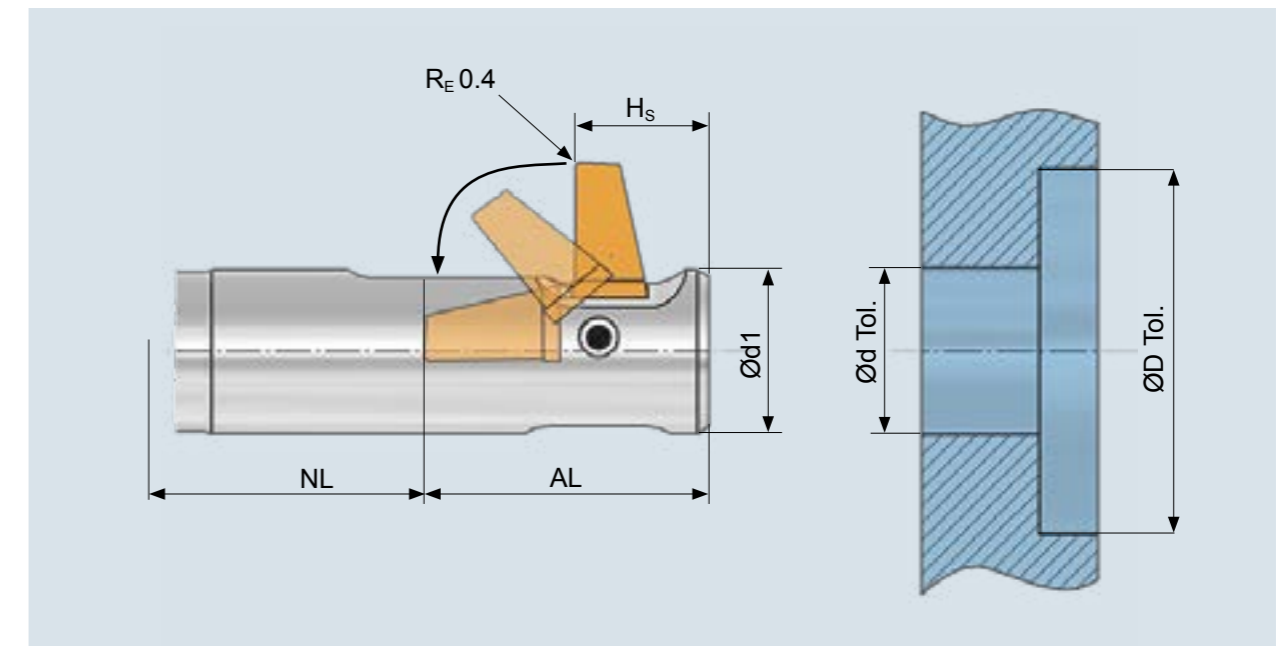

Caption

Ød Tol.	Tolerance Bore diameter	+0.1 0	+0.2 0	NL	Working length (see page 137ff.)
ØD Tol.	Tolerance Counterbore diameter	±0.2	±0.3	AL	Swing length (see page 137ff.)
Ød1	Tool diameter			Hs	Blade height (see page 137ff.)
RE	Edge radius standard	0.4 mm			

NOTE

Please pay attention to the recommended bore hole tolerance. Bore with bigger tolerance can cause problems (tool is rubbing in the bore, reduced counterbore diameter).

Furthermore, mind the tool collision diameter (counterbore diameter +2.0 mm) when you move the tool to the tool storage. Reason: The blade can fold out of the blade housing by its own weight.

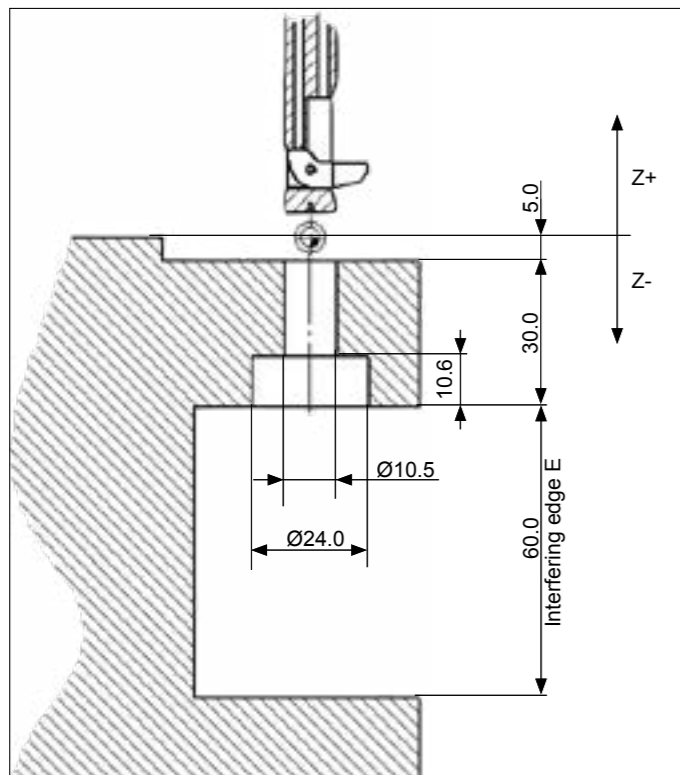

Application example

Counterbore M10 for Socket Head Cap Screw with internal hexagonal recess DIN 974-1.

Dimension according to drawing

Bore diameter d	10.5 mm
Counterbore diameter D	24.0 mm
Working length	approx. 30.0 mm
Counterbore depth	10.6 mm
Interfering edge E	60.0 mm
Material	Steel C45

1. Tool selection and series selection

Tool selection by bore diameter and counterbore diameter (see page 142)

Tool: Bore diameter 10.5 mm
Counterbore diameter 24.0 mm
Result series \underline{D} / 50 mm

Resulting part number: **BSF-D-1050/050-12.0**

2. Blade selection

Blade selection by series (see page 142)

Blade: Series \underline{D} (Bore diameter 10.5 mm)
Material steel C45: Carbide = 1
Coating A

Resulting part number: **BSF-M-D-1A-12.0**

FANUC control

Workpiece carbon steel C45

Cutting data (see page 167)

$V_c = 30$ m/min. → $S = 400$ rev./min.

$F = 0.05$ mm/rev.

Activation speed (see page 168)

Counterbore ratio = $24.0 : 10.5 = 2.28$

→ Activation speed = 2500 rev./min.



Position the tool above the top material surface, spindle stop, internal coolant ON, 2-5 sec. dwell time for coolant pressure build-up (depending on the pump), the blade retracts.

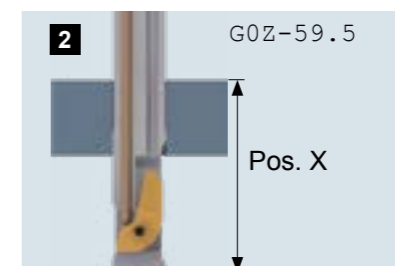

Traverse in rapid feed to position X.
(Position X = 5.0 mm + 30.0 mm + swing length¹ 22.5 mm + safety distance 2.0 mm)

¹ Values for swing length (AL) see page 137 onwards



Switch OFF internal coolant, start activation speed², 1-2 sec. dwell time (attention to coolant pressure), blade swings out into the working position.

Recommended internal coolant pressure: 20-50 bar

² Values for activation speed see page 168

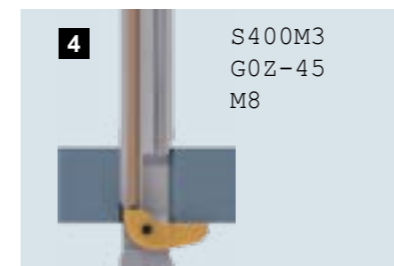

Travel the tool in rapid feed with working speed³ until 0.25 mm below the rear material surface (attention burr size, part tolerances). External coolant on.

³ Cutting data see page 167

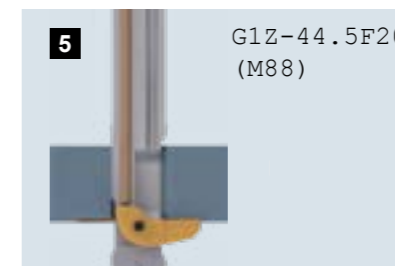

Start machining in working feed³. When full cut is reached (0.25 mm deep) internal coolant ON especially when working with deeper counterbores. Attention to internal coolant pressure particularly when machining soft materials!



Continue machining to desired counterbore depth. Cutting free without internal coolant (recommendable!).

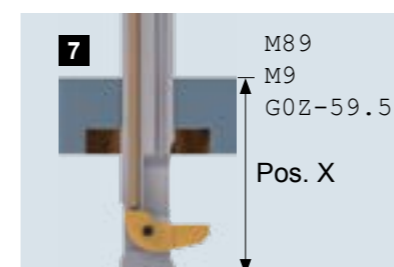

When the counterbore depth is reached, switch OFF internal coolant, in rapid feed back to position X.



Spindle stop, internal coolant ON, 2-5 sec. dwell time (attention coolant pressure), blade retracts.

Recommended internal coolant pressure: 20-50 bar



Now, move out of the workpiece in rapid speed.

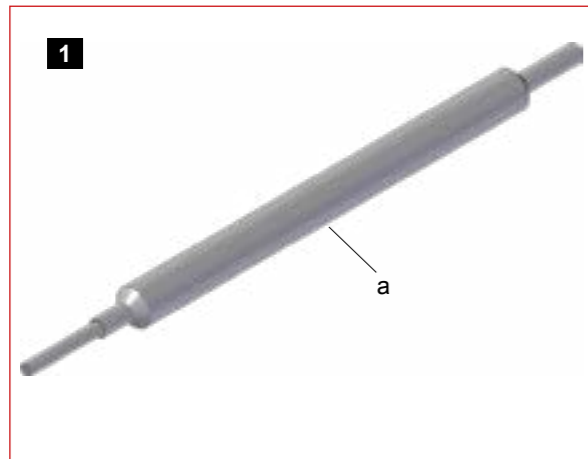

1 **Dismantling** - We supply an assembly pin (a) for the BSF blade change.

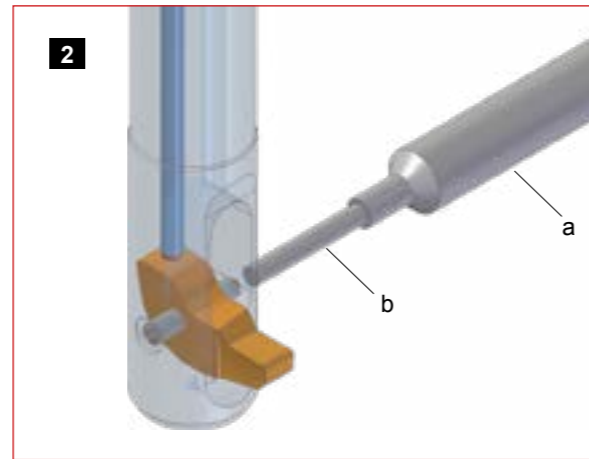

2 Use the stepped end (b) of the assembly pin and position the assembly pin with the slot free end onto the split pin. Press the assembly pin in until the split pin falls out and the blade is free to be removed.

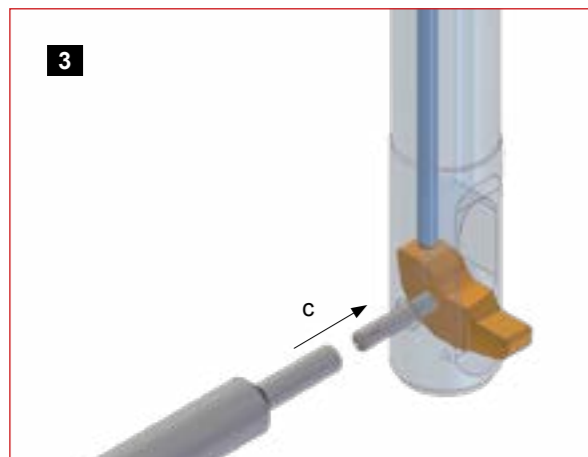

3 **Assembling** - Insert the blade. Then insert the split pin with the flat end of the assembly pin first and position the blade (c).

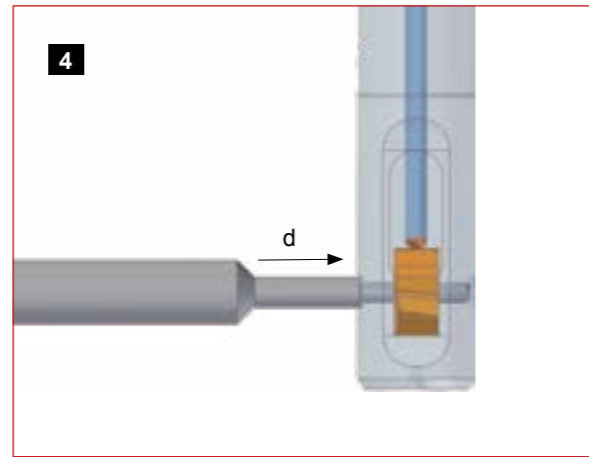

4 Push the split pin with the non-stepped end of the assembly pin until it is flush with the blade housing (d). Blade is fixed in place. Carry out function check.

NOTE

The blade must move freely by its own weight. If it is not, dismantle the blade and repeat the steps listed above. The blade and blade housing must be checked for soiling.

After an extended storage time it is recommended to check that the blade moves out freely. Dried oil, coolant or dust may cause the blade to stick.

Every time the blade is changed **the split pin must be replaced** (pin is included in blade shipment). Using a split pin several times may cause blade fixing problems.

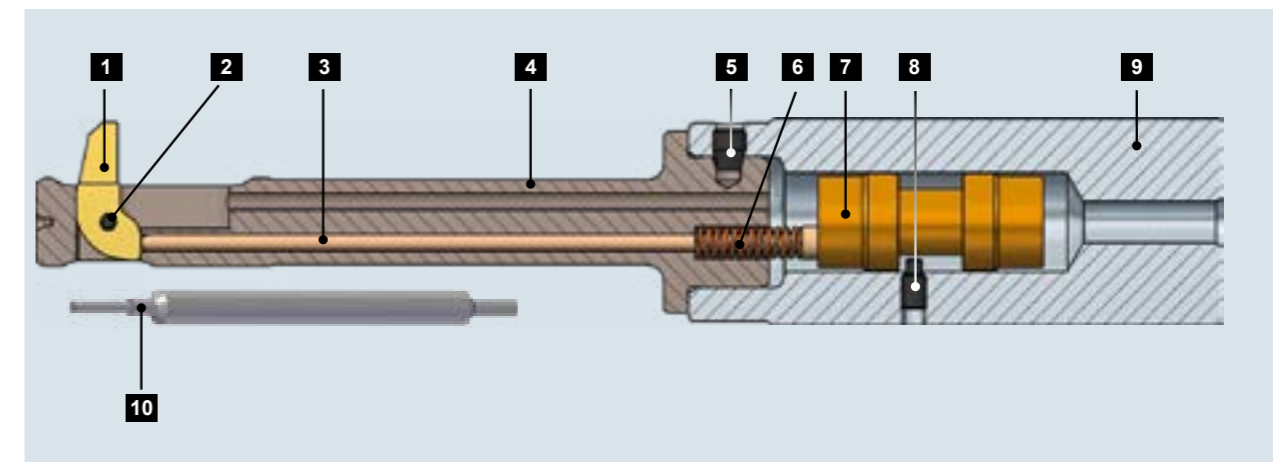

- 1** Couteau (voir p. 137 e, 179)
- 2** Split pin
- 3** Control bolt
- 4** Blade housing
- 5** Clamping screw
- 6** Pressure spring
- 7** Piston
- 8** Stop screw
- 9** Shank
- 10** Assembly pin
- 11** Allen wrench for Pos. 5

BSF-A-	Pos. 2	Pos. 3	Pos. 4	Pos. 5	Pos. 6	Pos. 7	Pos. 8	Pos. 9	Pos. 10	Pos. 11
	BSF-E-	BSF-B-	BSF-N-A-	GH-H-S-	GH-H-F-	BSF-E-	GH-H-S-	BSF-S-	BSF-V-	GH-H-S-
0650/040-6.5	0009	0001	0650/N025/040	0201	0052	0014	0302	0003	0009	2023
0650/040-7.0	0009	0001	0650/0000/040	0201	0052	0014	0302	0003	0009	2023
0650/040-7.5	0009	0001	0650/P025/040	0201	0052	0014	0302	0003	0009	2023
0700/040-7.0	0009	0002	0700/0000/040	0201	0052	0014	0302	0003	0009	2023
0700/040-7.5	0009	0002	0700/P025/040	0201	0052	0014	0302	0003	0009	2023
0700/040-8.0	0009	0002	0700/P050/040	0201	0052	0014	0302	0003	0009	2023

BSF-B-	Pos. 2	Pos. 3	Pos. 4	Pos. 5	Pos. 6	Pos. 7	Pos. 8	Pos. 9	Pos. 10	Pos. 11
	BSF-E-	BSF-B-	BSF-N-B-	GH-H-S-	GH-H-F-	BSF-E-	GH-H-S-	BSF-S-	BSF-V-	GH-H-S-
0750/040-7.5	0018	0003	0750/N025/040	0201	0052	0014	0302	0003	0009	2023
0750/040-8.0	0018	0003	0750/0000/040	0201	0052	0014	0302	0003	0009	2023
0750/040-8.5	0018	0003	0750/P025/040	0201	0052	0014	0302	0003	0009	2023
0800/040-8.0	0018	0003	0800/0000/040	0201	0052	0014	0302	0003	0009	2023
0800/040-8.5	0018	0003	0800/P025/040	0201	0052	0014	0302	0003	0009	2023
0800/040-9.0	0018	0003	0800/P050/040	0201	0052	0014	0302	0003	0009	2023
0850/040-8.5	0018	0004	0850/P025/040	0201	0052	0014	0302	0003	0009	2023
0850/040-9.0	0018	0004	0850/P050/040	0201	0052	0014	0302	0003	0009	2023
0850/040-9.5	0018	0004	0850/P075/040	0201	0052	0014	0302	0003	0009	2023

BSF-C-	Pos. 2	Pos. 3	Pos. 4	Pos. 5	Pos. 6	Pos. 7	Pos. 8	Pos. 9	Pos. 10	Pos. 11
	BSF-E-	BSF-B-	BSF-N-C-	GH-H-S-	GH-H-F-	BSF-E-	GH-H-S-	BSF-S-	BSF-V-	GH-H-S-
0900/050-9.5	0010	0005	0900/N025/050	0201	0053	0014	0302	0003	0006	2023
0900/050-10.0	0010	0005	0900/0000/050	0201	0053	0014	0302	0003	0006	2023
0900/050-10.5	0010	0005	0900/P025/050	0201	0053	0014	0302	0003	0006	2023
0950/050-10.0	0010	0005	0950/0000/050	0201	0053	0014	0302	0003	0006	2023
0950/050-10.5	0010	0005	0950/P025/050	0201	0053	0014	0302	0003	0006	2023
0950/050-11.0	0010	0005	0950/P050/050	0201	0053	0014	0302	0003	0006	2023
1000/050-10.5	0010	0005	1000/P025/050	0201	0053	0014	0302	0003	0006	2023
1000/050-11.0	0010	0005	1000/P050/050	0201	0053	0014	0302	0003	0006	2023
1000/050-11.5	0010	0005	1000/P075/050	0201	0053	0014	0302	0003	0006	2023

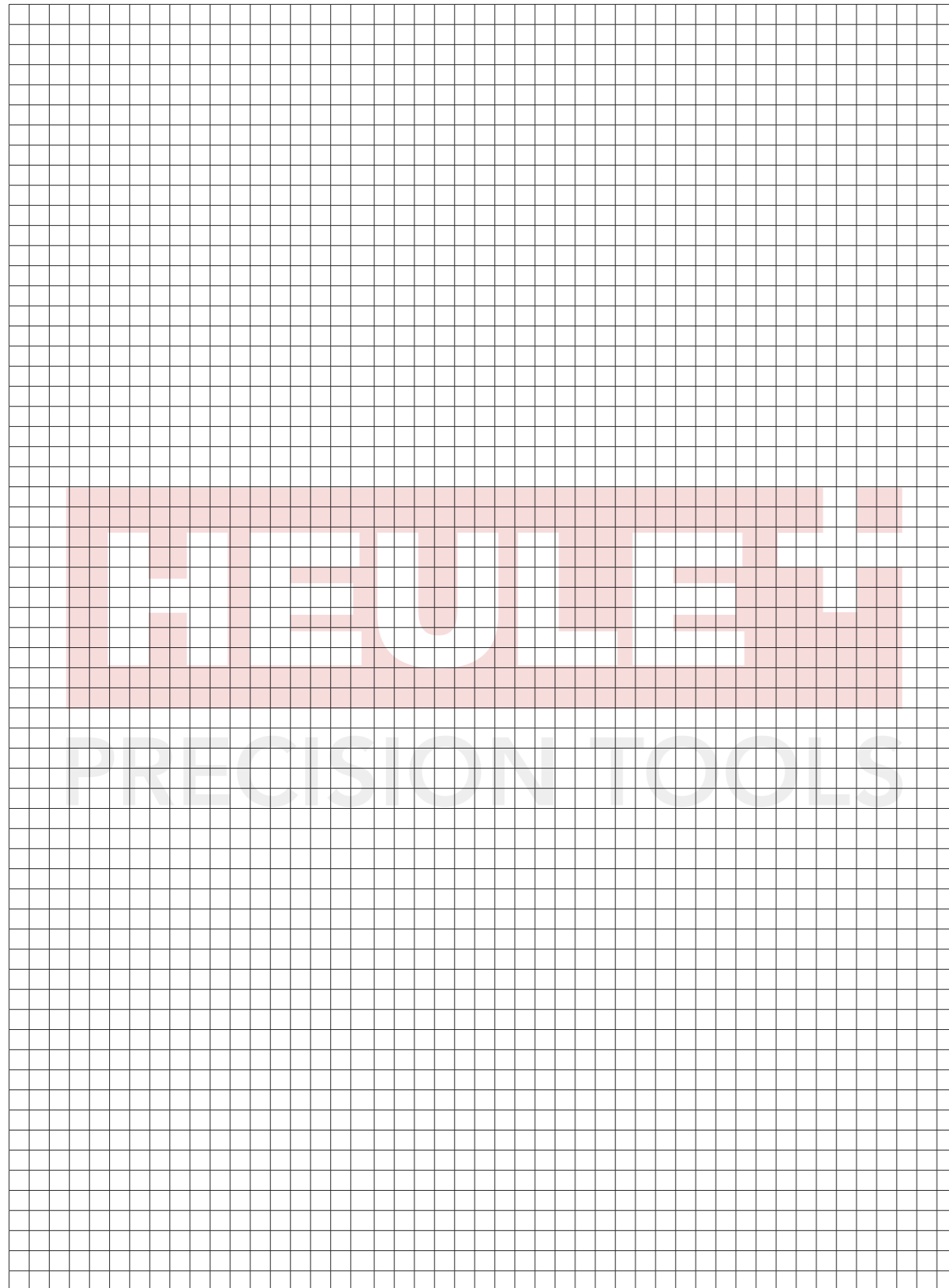

Blade Dimensions

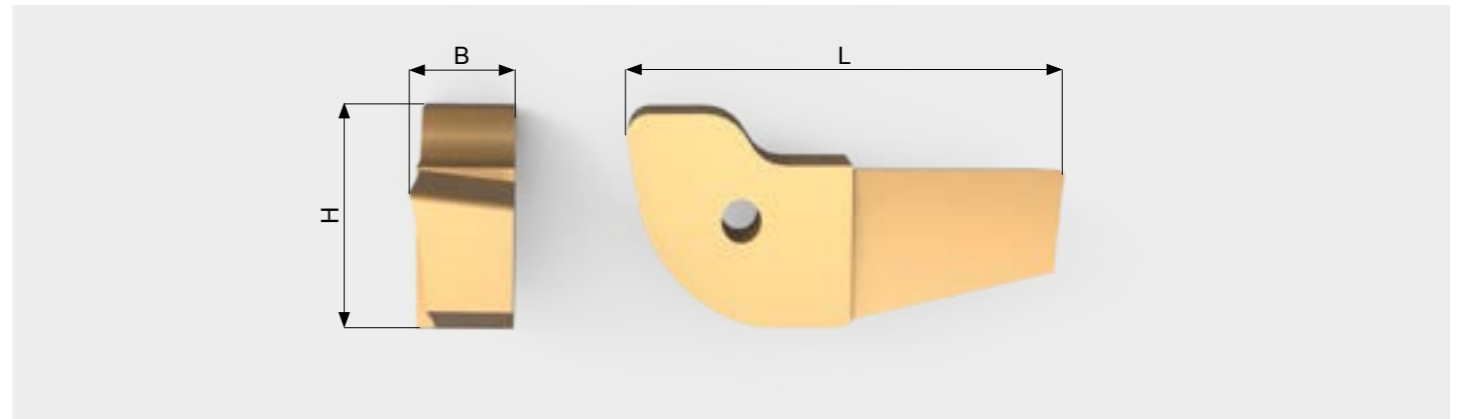

Blade Part No.	Length L	Width B	Height H
BSF-M-A-1A-3.0	7.70	2.00	4.50
BSF-M-A-1A-4.5	8.40	2.00	4.50
BSF-M-A-1A-6.0	9.20	2.00	4.50
BSF-M-A-1A-7.5	9.90	2.00	4.50
BSF-M-A-1A-9.0	10.70	2.00	4.50
BSF-M-B-1A-3.5	8.90	2.50	5.50
BSF-M-B-1A-5.0	9.60	2.50	5.50
BSF-M-B-1A-6.5	10.40	2.50	5.50
BSF-M-B-1A-8.0	11.10	2.50	5.50
BSF-M-B-1A-9.5	11.90	2.50	5.50
BSF-M-B-1A-11.0	12.70	2.50	5.50
BSF-M-C-1A-4.0	10.80	3.00	6.50
BSF-M-C-1A-5.5	11.60	3.00	6.50
BSF-M-C-1A-7.0	12.30	3.00	6.50
BSF-M-C-1A-8.5	13.10	3.00	6.50
BSF-M-C-1A-10.0	13.80	3.00	6.50
BSF-M-C-1A-11.5	14.60	3.00	6.50
BSF-M-C-1A-13.0	15.30	3.00	6.50
BSF-M-D-1A-4.5	12.50	3.50	7.25
BSF-M-D-1A-7.0	13.80	3.50	7.25
BSF-M-D-1A-9.5	15.00	3.50	7.25
BSF-M-D-1A-12.0	16.30	3.50	7.25
BSF-M-D-1A-14.5	17.50	3.50	7.25
BSF-M-E-1A-5.0	14.30	4.50	8.50
BSF-M-E-1A-7.5	15.50	4.50	8.50
BSF-M-E-1A-10.0	16.80	4.50	8.50
BSF-M-E-1A-12.5	18.10	4.50	8.50
BSF-M-E-1A-15.0	19.30	4.50	8.50
BSF-M-E-1A-17.5	20.60	4.50	8.50
BSF-M-F-1A-5.5	17.20	5.00	10.00
BSF-M-F-1A-9.0	19.00	5.00	10.00
BSF-M-F-1A-12.5	20.80	5.00	10.00
BSF-M-F-1A-16.0	22.60	5.00	10.00
BSF-M-F-1A-19.5	24.30	5.00	10.00
BSF-M-G-1A-6.0	20.80	6.00	12.00
BSF-M-G-1A-10.5	23.10	6.00	12.00
BSF-M-G-1A-15.0	25.40	6.00	12.00
BSF-M-G-1A-19.5	27.70	6.00	12.00
BSF-M-G-1A-24.0	29.90	6.00	12.00

FAQ BSF

Question	Answer
The blade swings out on its own after the spindle stops (vertical position), is that normal?	Yes. The BSF is designed so the blade swings out automatically since it is not fixed when the internal coolant pressure is off. Nevertheless, it is compulsory to set the recommended activation speed for machining.
After running the machine, a counterbore is missing.	Has the correct correct activation speed been programmed? Please check if the blade is sticking in the blade housing. If it is, dismount the blade and clean the window of the blade housing and the blade itself.
Does it matter which side you mount the split pin in?	No.
There is a bore hole tolerance of H7. Does the BSF tool damage the bore?	Yes, it is a single blade tool. We recommend to counterbore on a smaller bore diameter (semi-finished bore) and to open the bore to the correct diameter after the counterbore operation.
Is it possible to hold the BSF tool in a shrink system?	No. Shank and other BSF items are manufactured out of tool steel. These parts have other shrinking parameters than carbide which is the common material (shank) for shrink systems!
The blade housing is fixed with 3 clamping screws. Is there a recommended fixing procedure?	No. The blade housing can be set in any position.
Is filtering of the coolant absolutely necessary?	Yes. The cooling agent has to be filtered by a 25my filter.
Does the tool work with a coolant pressure of under 20 bar?	It may be possible but every application has to be verified individually.
Is it possible to run the internal coolant while machining?	Yes, but only when the blade is full cutting mode.

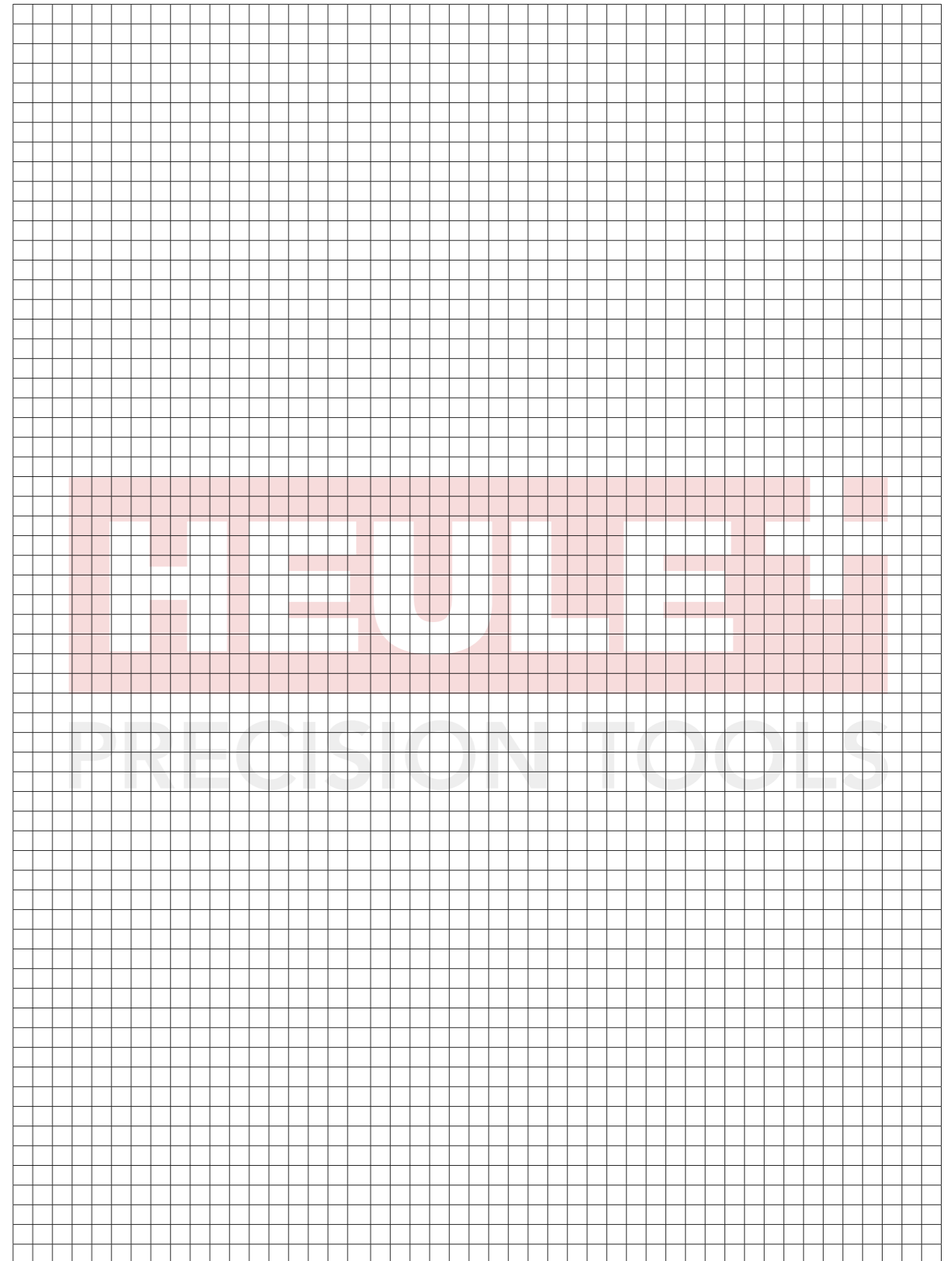



SOLO Online Information



Product Video

www.heule.com/en/counterboring-tool/solo



Case Studies

www.heule.com/en/case-studies/?t=101



Contact Sales Represent.

www.heule.com/en/contact-sales-representatives



Request for Quote Form

www.heule.com/en/Anfrageformular



Manual

www.heule.com/en/service/manual/solo



SOLO

Independent spotfacing and countersinking front and back in one operation.

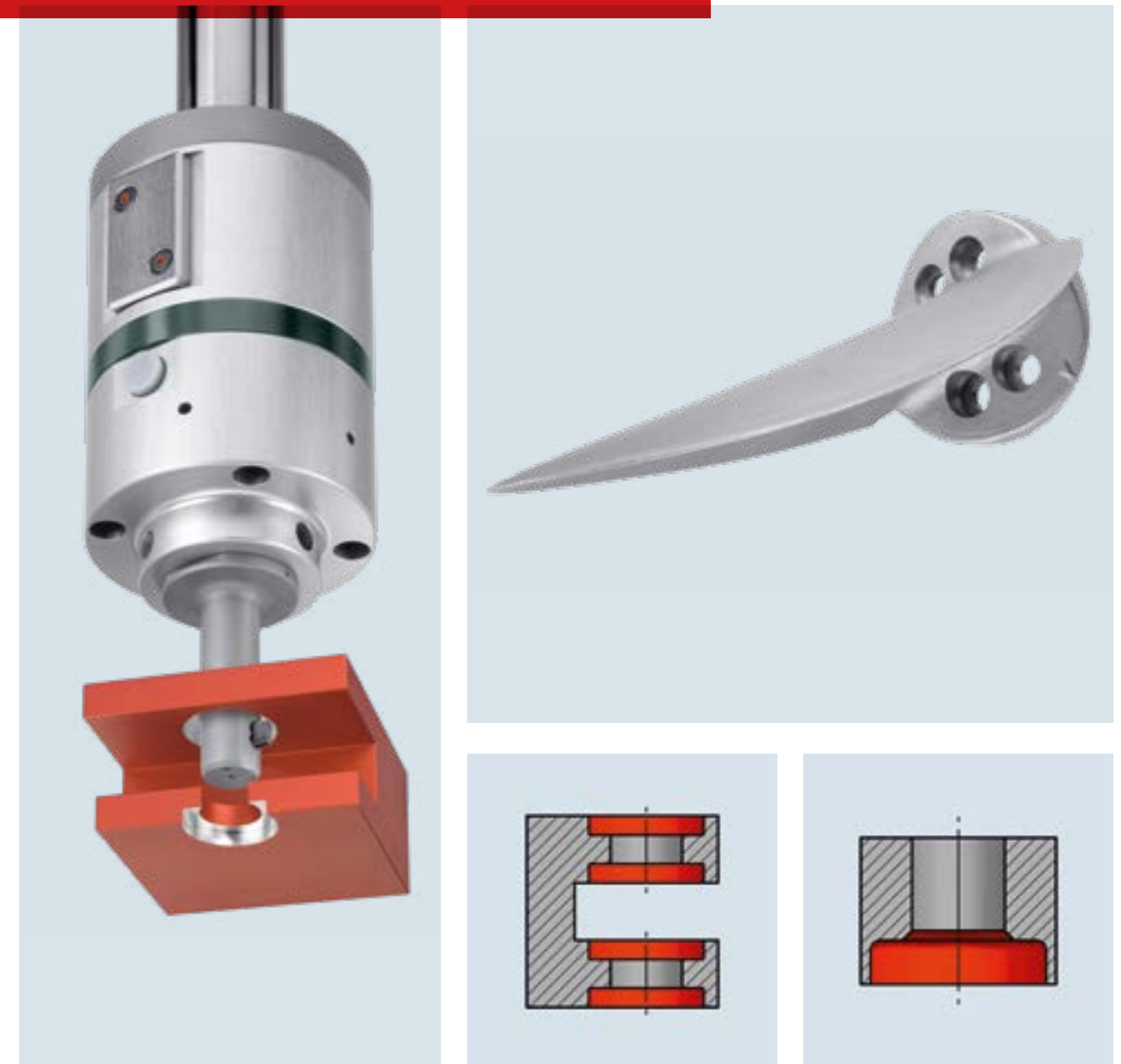

SOLO



Introduction

SOLO – The Automatic Front and Back Counterboring Tool



Machine automated counterboring and form-sinking, front and back, in one single pass.

With consistent simplicity and process capability, the SOLO tool sells itself. Its successful operation in the aircraft industry for many years confirms its reliability and a superior product off the machine with maximum efficiency is guaranteed.

Blade housing, blade control and blade are designed individually to the customer-specific requirements. Your project, your specifications: because no application is the same.

Characteristics and Advantages

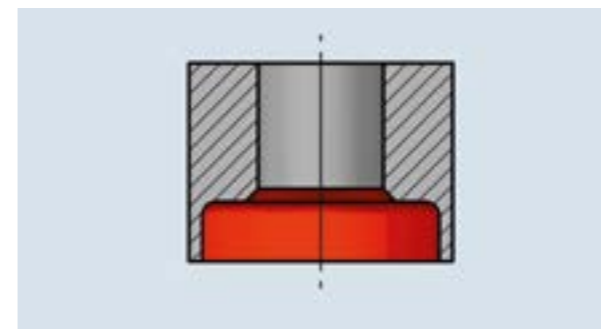

- SOLO allows for automatic front and back counterboring without requiring the workpiece to be turned.

- The access to the rear bore edge is gained through the bore itself.

- The SOLO system can be used for bore diameters starting from Ø6.0 mm. Countersink diameters of up to Ø49.0 mm are achievable.

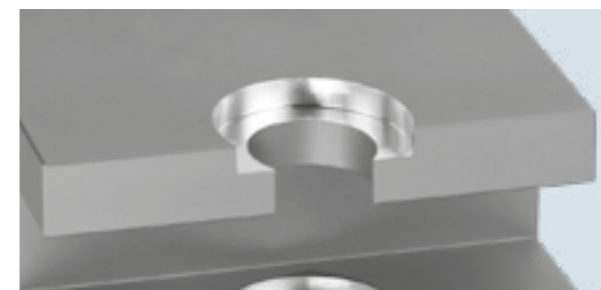

- The maximal bore-counterbore-ratio is $2 \times \text{bore-}\varnothing d - 1.0 \text{ mm}$ in normal cases including material with high strength properties such as titanium or Inconel.

- SOLO handles workpieces with interrupted bore edges without any difficulties, even in materials with very high tensile strength.



- Excellent process reliability and performance due to optimal specification to suit your particular applications.

- Modular setup: The tool head and the shank are standard. The blade housing, the blade control and the blade are adapted to your application.

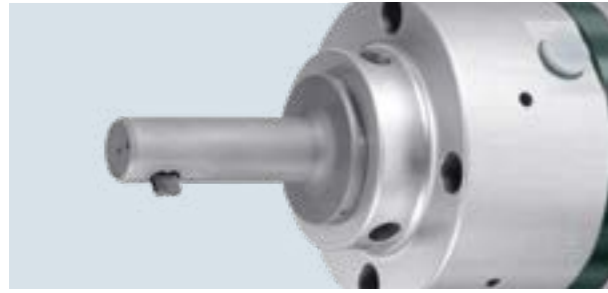

- The tool is immediately ready for operation on any machine (CNC, Transfer, Multi spindle, conventional machine) without any pre-settings.
- The SOLO tool functions reliably without anti-rotation device, change of spindle rotation, coolant pressure or contact mechanism.

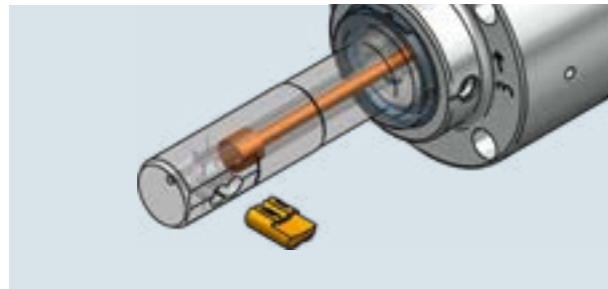

- Easy to operate: The blade or the support of the inserts will be extended reliably by the centrifugal force generated by the activation speed in SOLO. Alternatively, SOLO2 retracts the blade through centrifugal force.

- Made with material-dependent cutting geometries and coatings, the carbide blades are easily changed by hand in the machine.

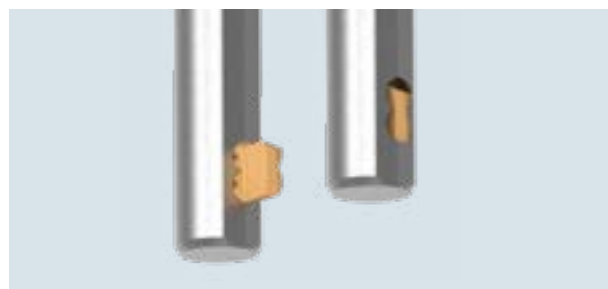

- The reliable blade system and housing is resistant to dirt and chips.

- Simple construction together and fully mechanical operation in a closed system guarantee reliable functioning.

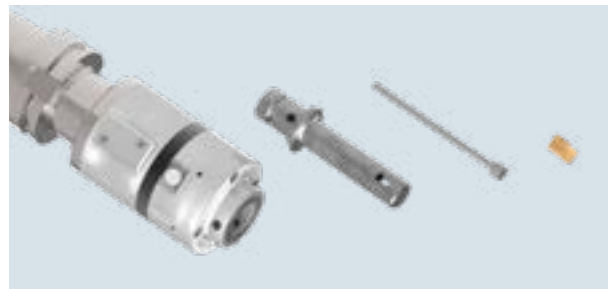

- Simple, easy-to-maintain tool design.
- Superior price/performance-ratio, excellent process capability with minimum maintenance make SOLO first choice when it comes to efficient high-volume production.

This tool system is simple and easy-to-use. The high process capability and efficient operation give SOLO the competitive edge for successful use in high-volume production.

SOLO's application range:

Minimal bore-Ø	6.0 mm
Maximal sinking-Ø	49.0 mm
Maximal chip section (Counterbore width)	13.0 mm

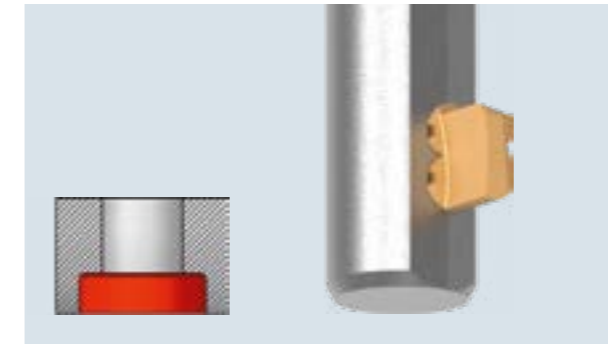

Back Spotfacing

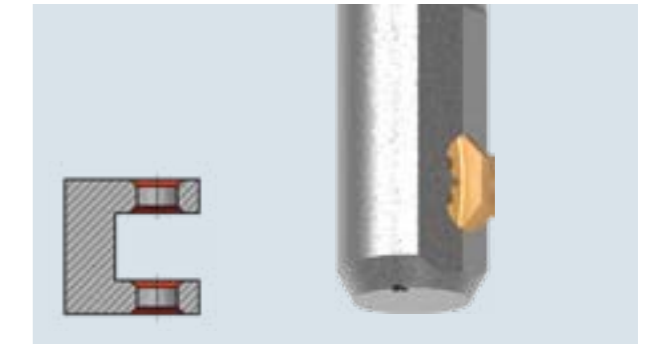

Chamfering front and back

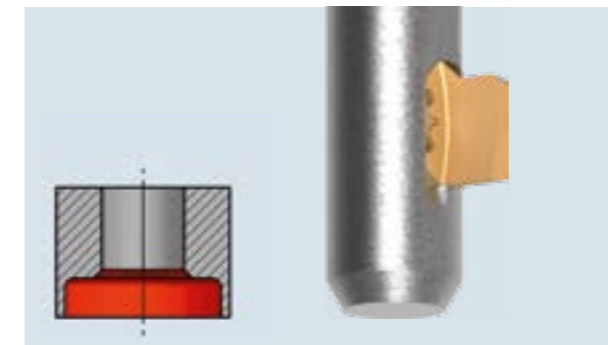

Formsinking backward

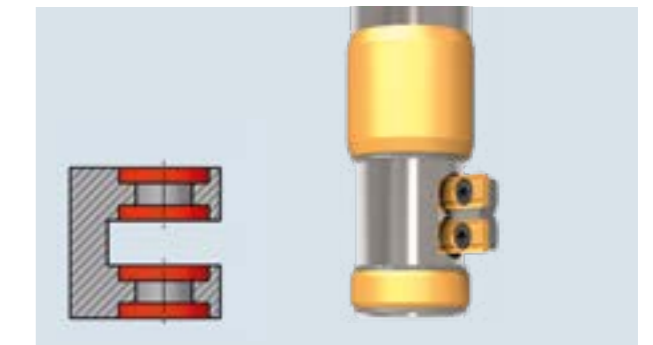

Insert holder with inserts

NOTE

Customer-specific solutions are process capable and designed to meet the requirements of the application in all aspects. Efficiency is the main focus of the SOLO tool concept. Please contact us and show us your application – we will design the right tool for you.

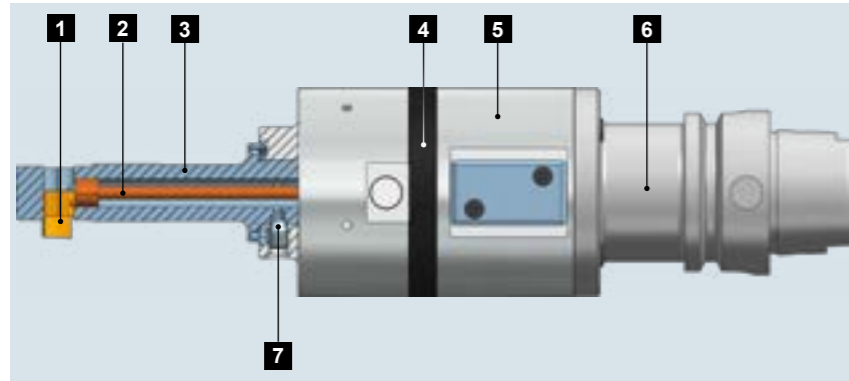

- 1 Solid carbide blade or Blade holder with inserts
- 2 Blade control
- 3 Blade housing
- 4 Center ring
- 5 Tool head
- 6 Shank direct adaption
- 7 Clamping screw

SOLO fulfills the requirements of diverse materials and applications. To do this, two systems with different machining parameters have been developed: SOLO and SOLO2. Although their appearance is almost identical, their mechanical setup is completely different.

SOLO:
For high machining speeds, exceeding 1900 rev./min.

SOLO2:
For low machining speeds up to 1400 rev./min., Retracting speed 1900 rev./min.

SOLO

SOLO operates with a minimum speed of 1900 rev./min. When standing still, the blade is in retracted position. It is only by exceeding the minimum speed that the blade is being extended into working position. Stopping the spindle moves the blade back into the blade housing. The distinguishing feature of SOLO is the black center ring.

SOLO2

The blade of the SOLO2 tool is extended whenever the spindle is stopped. The tool is meant for use up to a maximal machining speed of 1400 rev./min. The speed needed for retracting the blade is 1900 rev./min. It is only by exceeding this speed that the blade retracts safely into the blade housing. The distinguishing feature of SOLO2 is the green center ring.

Overview of distinguishing features	SOLO	SOLO2
Blade position at standstill (spindle stopped)	retracted	extended
Color center ring	black	green
Required speed for extending blade	1900 rev./min.	0 = standstill
Required speed for retracting blade	0 = standstill	1900 rev./min.
Machining speed	> 1900 rev./min.	0 – 1400 rev./min.

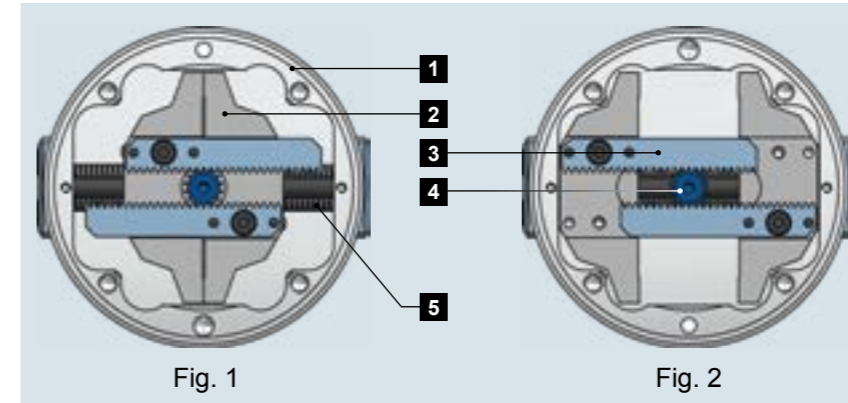

- 1 Control unit
- 2 Centrifugal elements
- 3 Toothed rack
- 4 Pinion
- 5 Return spring

Fig. 1: Spindle stopped: SOLO → Blade retracted; SOLO2 → Blade extended
Fig. 2: Spindle rotating: SOLO → Blade extended; SOLO2 → Blade retracted

Forced by the rotation of the tool at the indicated activation speed, two centrifugal weights start moving outwards up to the stop. The weights moving outwards are turning a pinion via two toothed racks. This pinion drives the blade out or in by

means of the blade control. The end of the blade control is a bolt that rests in the blade groove. The distance traveled by the centrifugal weights causes a turn of the blade control by 180° which moves the blade out into working position.

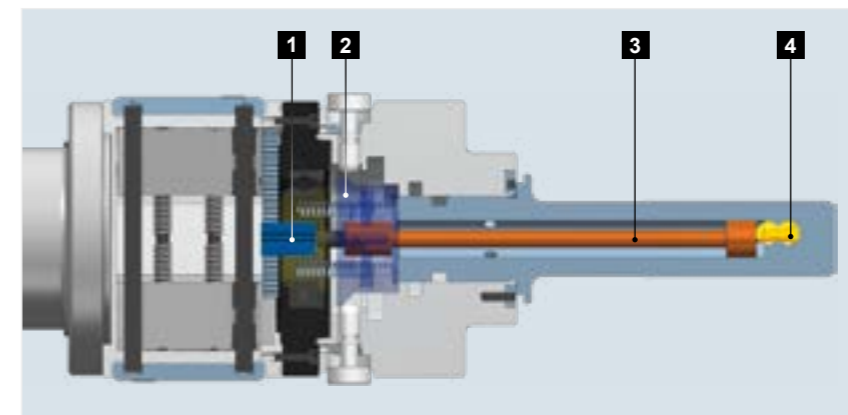

- 1 Gear wheel
- 2 Blade control support
- 3 Blade control
- 4 Blade

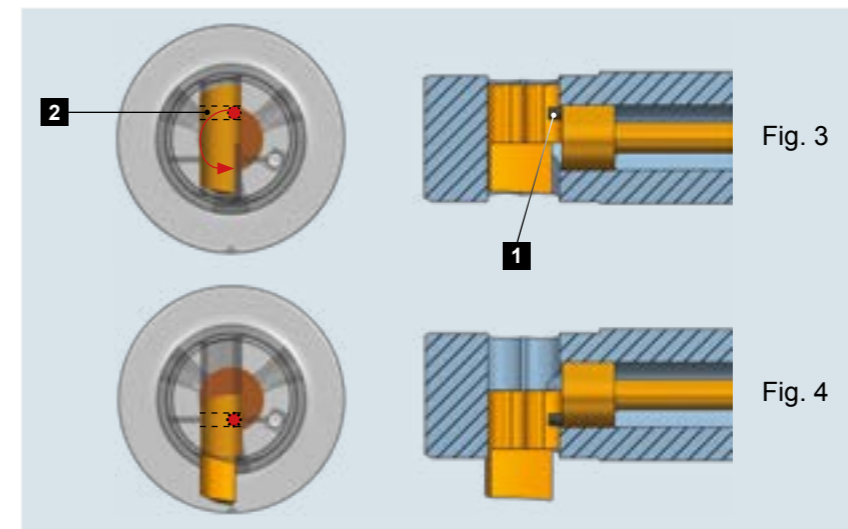

- 1 Blade control bolt
- 2 Blade groove

Fig. 3: Blade retracted
Fig. 4: Blade extended

SOLO Range Summary

The product range consists of the two different tool heads that distinguish SOLO from SOLO2. Since each tool is tailor-cut to the customer-specific application, there is no standardized range.

HEULE defines the tool according to the application data listed in this chapter.



Image 1: On the left SOLO, on the right SOLO2. Both featuring direct adaption shanks (standard).

	SOLO	SOLO2
Complete system	GH-B-O-0084	GH-B-O-0085
Center ring	black	green
Blade position at standstill	retracted	extended
Activation speed	1900 rev./min.	Spindle stop
Retracting speed	Spindle stop	1900 rev./min.
Machining speed	1900 - 3000 rev./min.	0 - 1500 rev./min.

Version with Large Adaption

The special version SOLO2S (S=Strong) features a reinforced blade housing and a reinforced support of the blade housing. The use of this ver-

sion has is mandatory in application cases where the bore diameter is larger than 30 mm.

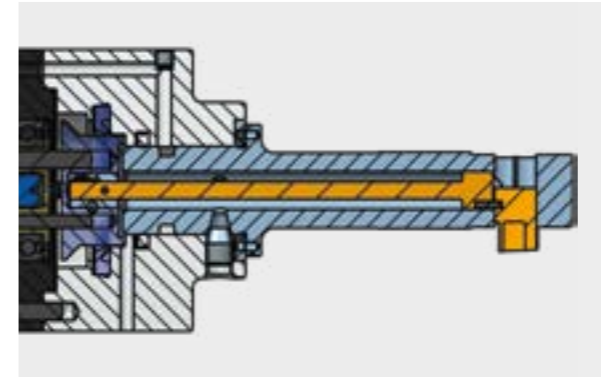

Image 1: SOLO2 Standard version

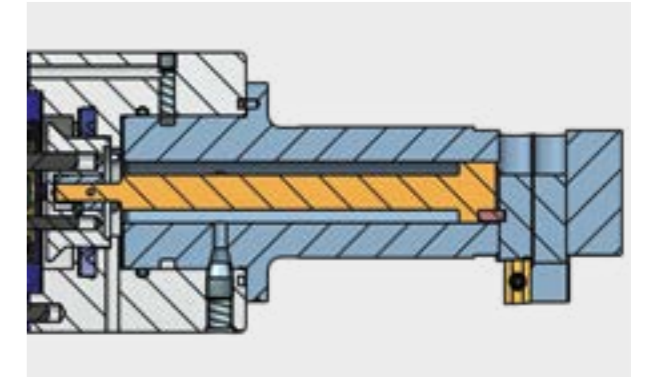

Image 2: SOLO2S Reinforced version

The use of bronze guide bushings is recommended for high transverse forces appearing at radii, chamfers and interrupted surfaces. In cases where the bore surface must not be damaged (i.e. soft materials or respective requirements on the bore surface) the use of guide bushings or rails should also be taken in consideration.

Bushings also help to avoid possible material build-up on the tool diameter. The fact that the relative circumferential speed of the bushing to the workpiece bore is equal to zero, spares the bore. This solution avoids undesired contact effects and guides the tool in an ideal manner. The resulting possible reduction of the tool diameter D1 down to the necessary shaft diameter creates additional space for chips.

Guide bushing behind the blade

The blade in the retracted position is not protected by the tool diameter D1 because the blade exceeds slightly the blade housing. A possible radial run-out on the tool (i.e. adaption or machine) may lead to a damage of the bore wall when the tool enters or later exits the bore again. If the counterbore ratio and the tool stability allow it, the eccentricity will be defined so that the retracted blade is at least -1.0 mm away from the bore diameter.

Guide bushings ahead and after the blade

In some cases however, this condition cannot be achieved. Then, a further guide bushing has to be placed ahead of the blade. Thus, the tool is guided permanently. By doing so, it has to be taken into account that adding a guide bushing weakens the blade housing. This fact again limits the use of guide bushings.

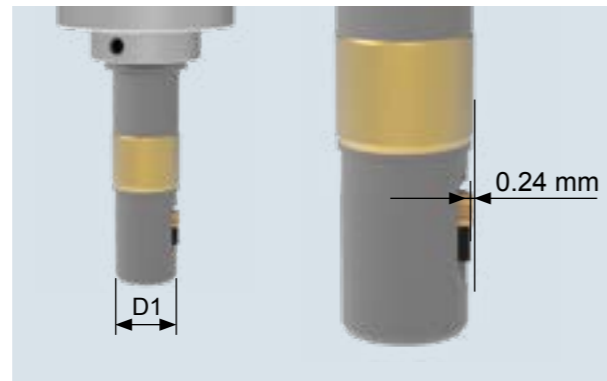

Image 1: SOLO with retracted blade that shows only an insufficient distance to the bore wall.

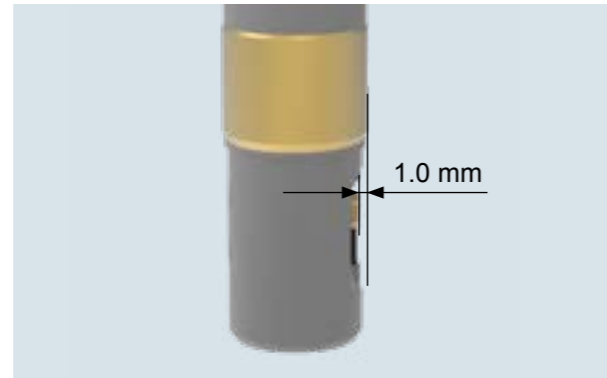

Image 2: In this example the distance between blade and bore wall is sufficient.



Image 3: SOLO with retracted blade protected by a guide bushing ahead and one after the blade.

Material	Designation / Material number
Bore	Bore diameter with tolerance Bore depth, working length
Counterbore / Countersink	Sinking width (Ø) resp. chamfer width (Ø) horizontally with tol. Sinking depth + if appl. geometric tolerances of the sinking
Chamfer	Chamfer angle with tolerance
Interfering edges etc.	Distances
Machine concept	Type Machining Center, feed unit, machine capability
Machining position	horizontally, vertically
Adaption to machine	Shank system
Production volume	Production quantity per year, lot size
Drawing workpiece	2D or 3D file (STEP, DXF, ...)

Technical Data and Settings

Cutting Data SOLO

Material	Condition	Tensile strength	Cutting speed	Feed
		(N/mm ²)		
Unalloyed steel		<500	50-90	0.03-0.1
Cast steel		500-850	50-90	0.03-0.08
Grey cast iron		<500	50-110	0.03-0.1
Ductile cast iron		300-800	50-90	0.03-0.08
Low alloy steel	annealed	<850	50-90	0.03-0.08
	tempered	850-1000	40-80	0.03-0.08
	tempered	>1000-1200	30-50	0.02-0.05
High alloy steel	annealed	<850	30-70	0.03-0.08
	tempered	850-1100	30-50	0.02-0.05
Stainless steel	ferritic	450-650	30-50	0.03-0.08
	austenitic	650-900	15-25	0.02-0.05
	martensitic	500-700	30-50	0.02-0.05
Special alloy (Inconel, titanium, ...)		<1200	15-25	0.02-0.05
Wrought or cast aluminium alloys			100-200	0.03-0.012
Copper alloy	Brass		50-90	0.03-0.08
	Bronze short-chipping		30-70	0.03-0.08
	Bronze long-chipping		20-30	0.02-0.05

WARNING NOTICE

All listed cutting data are standard values only! The cutting values depend on the amount of slope of the uneven bore edge. (i.e. high slope ► low cutting value). The feed also depends on the sloping ratio. In case of hard to machine materials or uneven bore edges, we recommend to apply cutting speeds that are at the lower end of the range for uneven bore edges.

Countersinking Tolerance

Application tolerances

Bore-Ø Tolerance	$\begin{matrix} +0.1 \\ 0 \end{matrix}$ mm	$\begin{matrix} +0.2 \\ 0 \end{matrix}$ mm
Countersink-Ø Tolerance	± 0.2 mm	± 0.3 mm

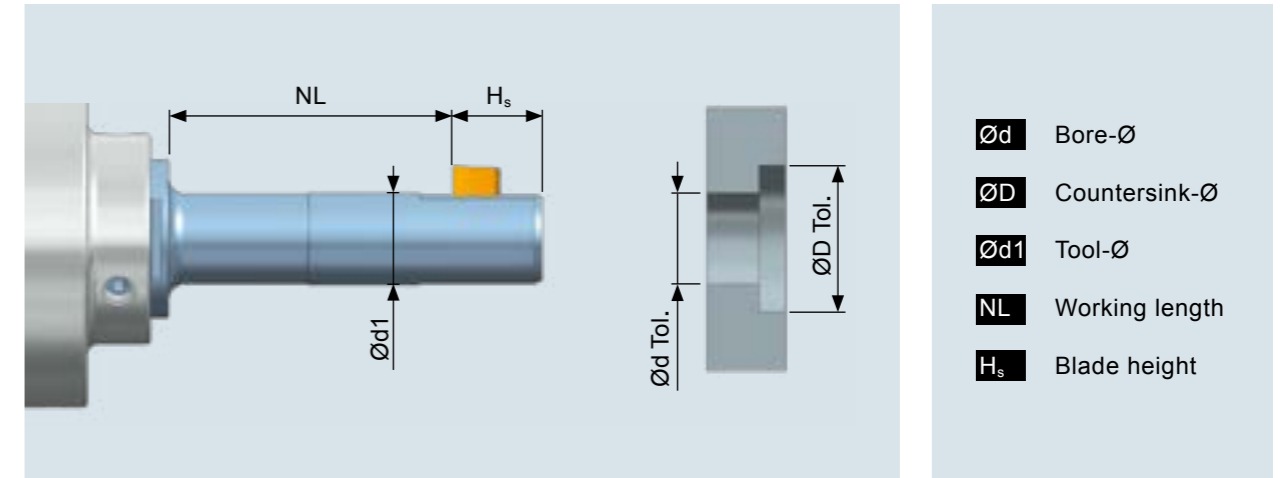

NOTE

Please observe the recommended value for the tolerance of the bore diameter (d). The larger the tolerance is chosen, the more side effects can occur (damaged bore, enlarging, countersink-Ø gets smaller).

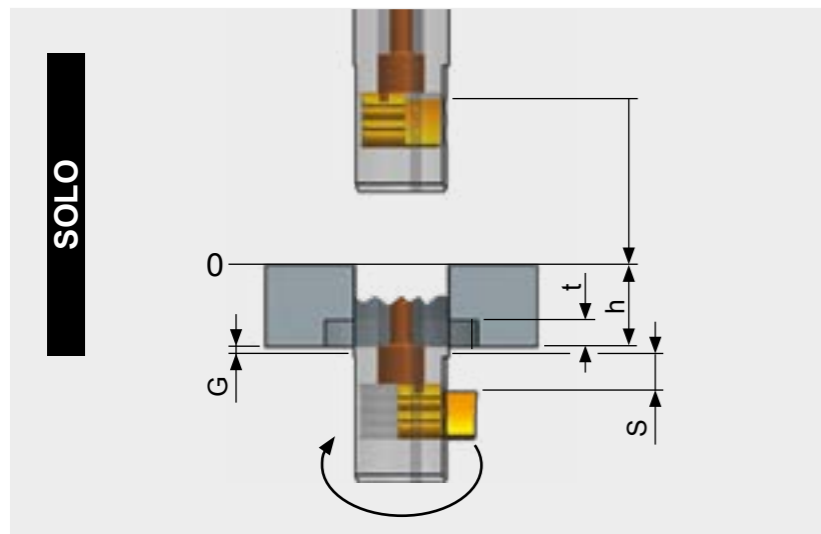

- 0** Zero line
- G** Burr height
- h** Workpiece thickness
- t** C'sinking depth
- S** Clearance distance

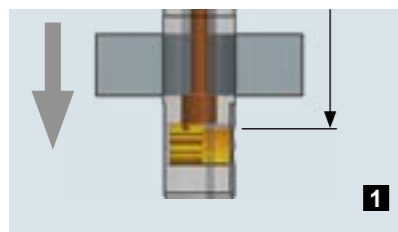

After spindle stop (Speed = 0, blade retracted), rapid traverse through the workpiece.

Position: $h + G + S$

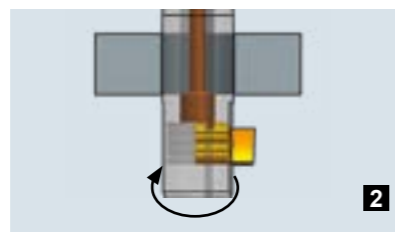

Activate spindle clockwise. Select correct activation speed to extend blade.

Attention: Dwell time 1 sec. at least. Increase speed to working speed. Switch coolant on.
Position: $h + G + S$

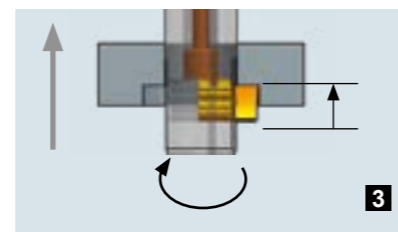

Machine workpiece backwards in working speed.

Position: $h - t$

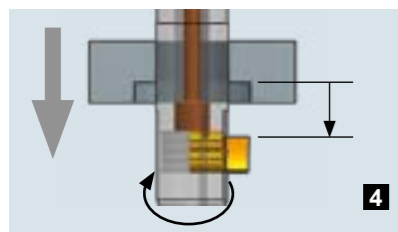

Travel out of countersink in rapid traverse. Switch off coolant.

Position: $h + G + S$

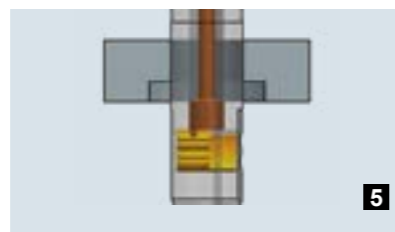

Stop the spindle. Select speed rate = 0 to retract blade.

Attention: Dwell time 1 sec. at least.

Position: $h + G + S$

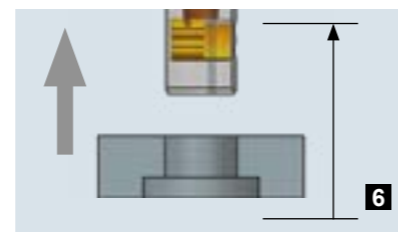

With stopped spindle (speed rate = 0) and in rapid traverse withdraw the tool from the workpiece.

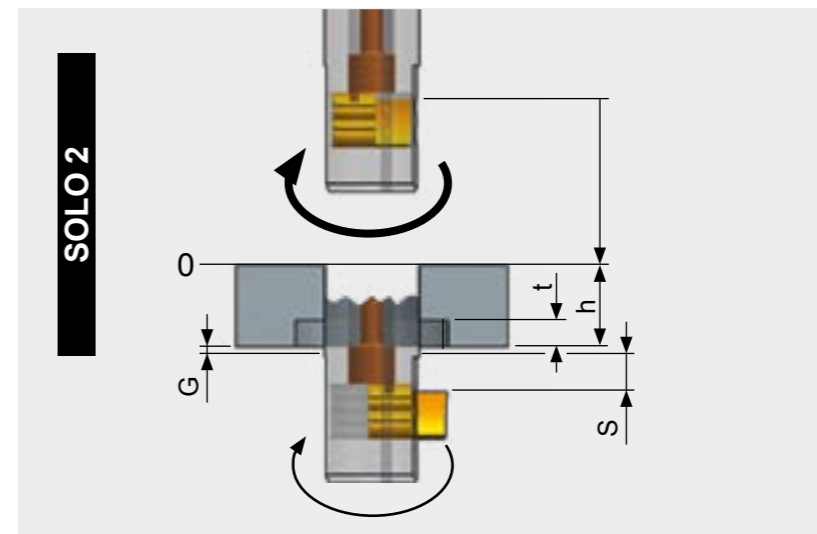

- 0** Zero line
- G** Burr height
- h** Workpiece thickness
- t** C'sinking depth
- S** Clearance distance

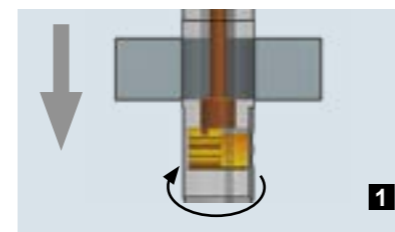

Activate spindle clockwise with retraction speed (speed = 1900 rev./min. minimum). The blade retracts. Travel through workpiece with rotating spindle and in rapid traverse.

Position: $h + G + S$

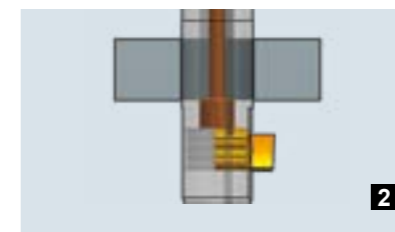

Stop the spindle. Dwell time 1 sec. at least. Switch on coolant. Set the speed to working speed.

Position: $h + G + S$

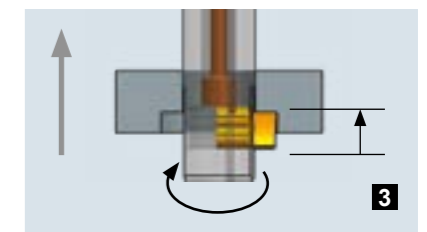

Machine the workpiece backwards in working speed and with working feed.

Position: $h - t$

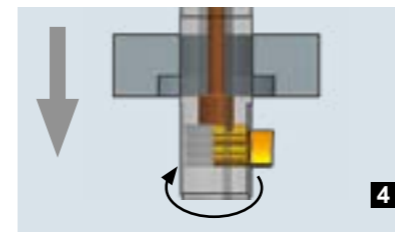

Travel out of countersink in rapid traverse. Switch off coolant.

Position: $h + G + S$

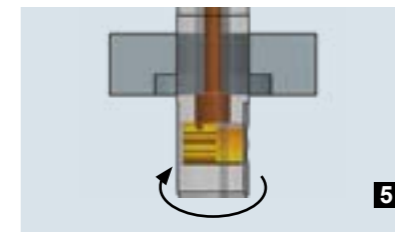

Retract blade by increasing spindle speed to 1900 rev./min. minimum.

Attention: Dwell time 1 sec. at least.

Position: $h + G + S$

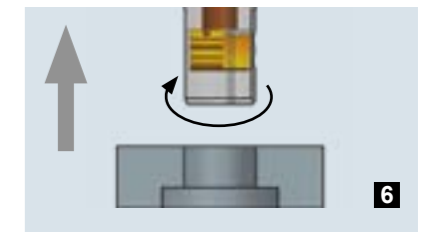

Travel through workpiece with retraction speed (Speed rate 1900 rev./min. minimum) and in rapid traverse and with retracted blade.

Maintenance and Servicing

Blade change

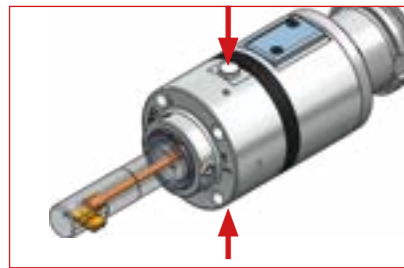

Dismantling of blade:
Push both buttons of the control unit at the same time. The blade control and the blade control pin will be retracted. Thus, the blade is released.

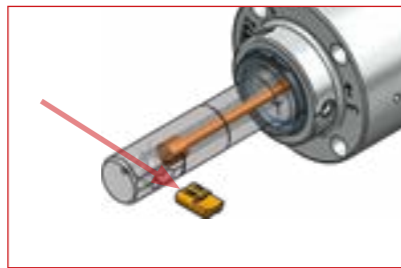

Push out the blade. Keep the buttons pressed until the blade is completely removed.

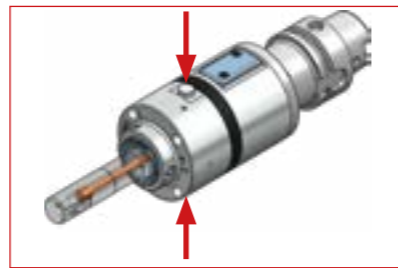

Insertion of blade:
Push both buttons of the control unit at the same time.

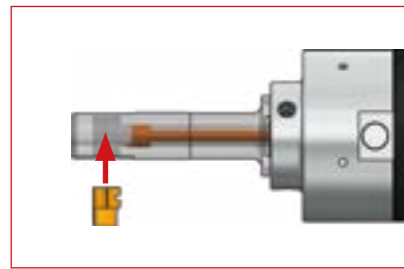

Insert blade in blade window to the extent that the cutting part of the blade remains fully visible. To do this keep on pushing the buttons of the control unit.

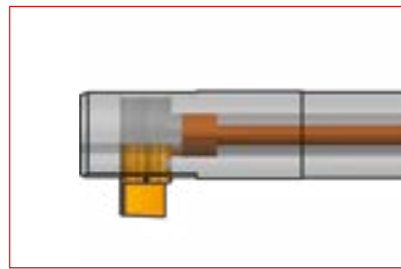

Release the buttons. Make sure that the buttons are extended fully.

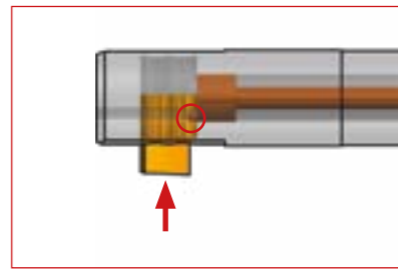

Position the blade in the blade window so that the blade control pin audibly engages into the blade.

NOTE
Attention: Please check the position of the blade control pin. If the blade housing or/and the blade control is assembled in the wrong way there is a danger of the cutting edge of the carbide blade being hit.

Change of Blade Housing and Blade Control

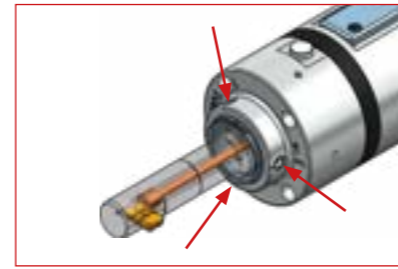

Dismantling:
Loosen the 3 clamp screws of the control unit and unscrew them only partly.

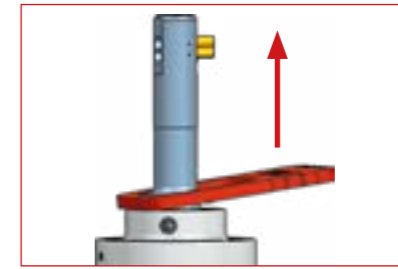

Pull the blade housing forward - away from the control unit. The blade house wrench simplifies the disassembly and should be used always.



Pull forward the blade control too by applying some force but without unscrewing anything.

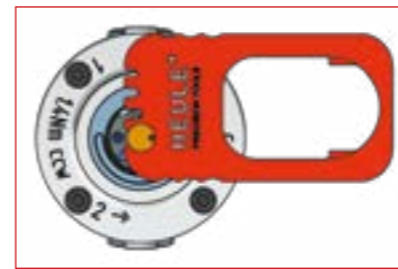

Please use the blade house wrench in case of small diameter and/or short working length.

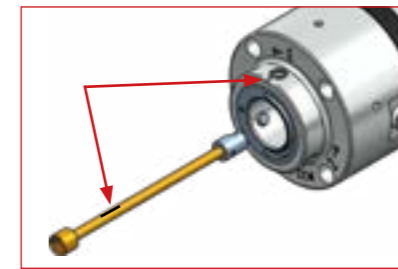

Assembly: Push blade control (snap mechanism + seal) well positioned with some force into the control unit.
Attention: Please make sure that the mark on the blade control and the mark on the control unit are aligned.

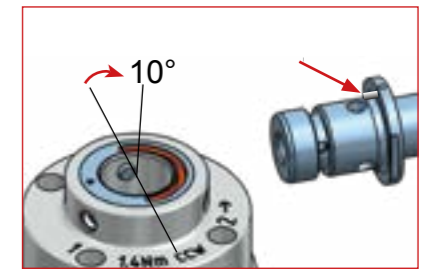

Mount the blade housing onto the control unit. Please make sure that the blade control bolt is mounted with a twist of approx. 10° into the clearance groove of the blade housing.

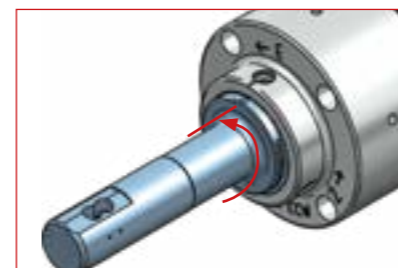

Then, align the mark of the blade housing with the mark of the control unit.

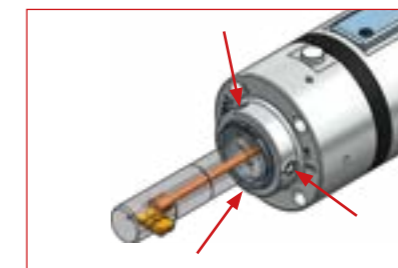

Screw the 3 clamp screws tightly. For this, please observe the torque value and screw order indicated on the control unit housing.



ATTENTION: Before setting to work after a change of blade housing and/or blade control, a function check is compulsory (refer to page 201).

Maintenance Intervals / Services

Compulsory maintenance interval: after 18 months or 200'000 strokes.

HEULE Werkzeug AG offers support and services for all products.

All service work requiring the opening of sealed screws has to be carried out by authorized personnel that has been certified by HEULE Werkzeug AG.

Professional maintenance work and timely service intervals assure a process safe functioning.

Compulsory Maintenance and Warning Notices

The maintenance work upon reaching the service interval is mandatory. HEULE Werkzeug AG would like to point to the fact that the maintenance **has to be** carried out by HEULE or a certified partner.

IMPORTANT: The control unit may be opened by **certified and authorized personnel exclusively.** HEULE Werkzeug AG rejects any responsibility after opening by a non-authorized body.

Only the following three procedures can be carried out by the customer:

- Blade change
- Change of blade housing
- Change of blade control

NOTE

If this provision is not complied with, there is a **risk of severe injuries.**

Negative effects from long periods of non-use

After not using the tool for a longer period of time, a manual function check **MUST** be carried out. During a longer period of non-use, residues of coolant and dirt dry up. This may lead to the blade and blade control sticking together. This sticking effect may

cause a malfunction or prevent the blade from being activated. In order to ensure proper functioning again, the tool has to be manipulated manually before setting to work.

Function Check

SOLO offers the possibility to check the function of the tool (extending and retracting of the blade) while it is standing still.

Procedure:

- 1 - Loosen the three clamp screws.
- 2 - Insert wrench over the blade housing.
- 3 - SOLO: Turn wrench clock wise, SOLO2: turn wrench anti-clock wise.

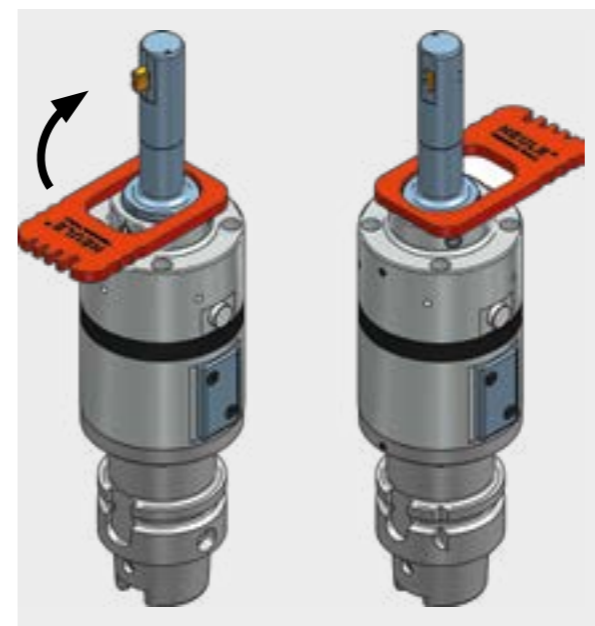

Image 1: SOLO

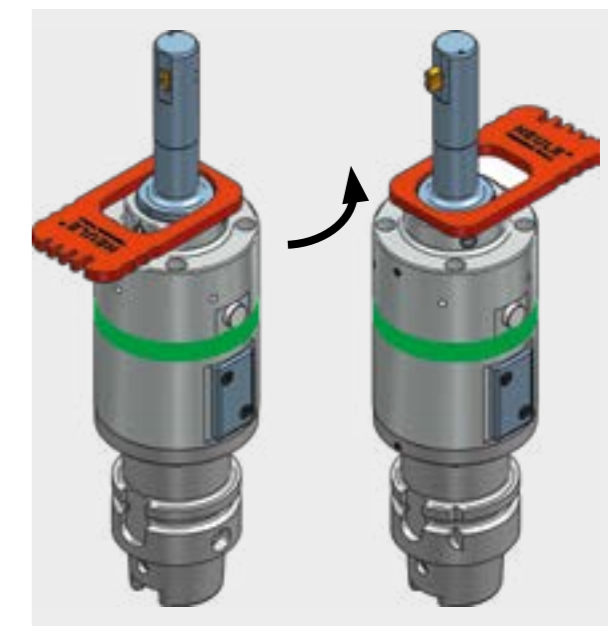

Image 2: SOLO2

- 4 - Please note that the blade extends if it is SOLO. If it is SOLO2 the blade will retract.
- 5 - After the Function Check, the SOLO wrench has to be turned back in the opposite direction until the positioning bolt hits the control unit at the start mark again. Then the blade housing is aligned with the groove in the control unit again.
- 6 - It is compulsory to remove the SOLO wrench before use - **if omitted there is a risk of severe injury.**
- 7 - Re-tighten the clamp screws again. **Please make sure to observe the correct order of screw tightening and torque value (values are marked on the tool).**
- 8 - The tool is ready for use now.
- 9 - Activate the tool 2 - 3 x in the machine.

ATTENTION!

Please carry out all SOLO wrench-swivel movements by hand gently in order to be able to recognize possible faults and malfunctions of the blade. The function check is recommended if:

- the tool has not been used for a longer period of time
- after blade change
- after change of blade housing
- after change of blade control
- a malfunction is evident or supposed
-

Before you start with the setting to work in the machine, make always sure that:

- all screws have been tightened,
- all auxiliary tools have been removed and that
- the blade housing sits firmly in the control unit.

In case of questions please contact your competent agent or HEULE directly.



GH-K Online Information



Product video
[http://www.heule.com/en/
countersinking-tool/gh-k](http://www.heule.com/en/countersinking-tool/gh-k)



Contact Sales Represent.
[www.heule.com/en/
contact-sales-representatives](http://www.heule.com/en/contact-sales-representatives)



Request for Quote Form
[www.heule.com/en/
Anfrageformular](http://www.heule.com/en/Anfrageformular)



GH-K

Wide range of chatter-free front countersinks with one single tool.

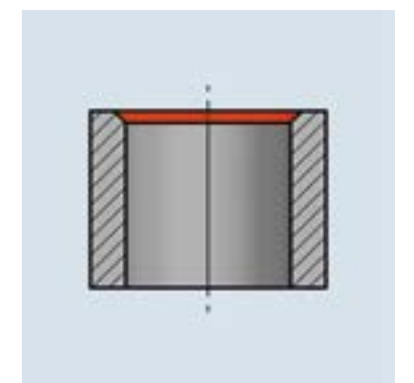
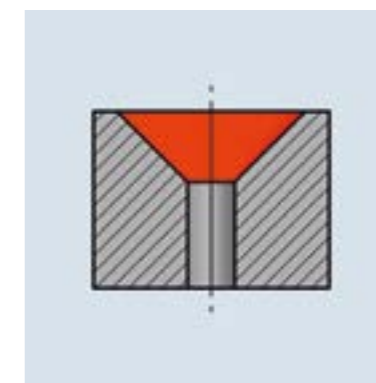
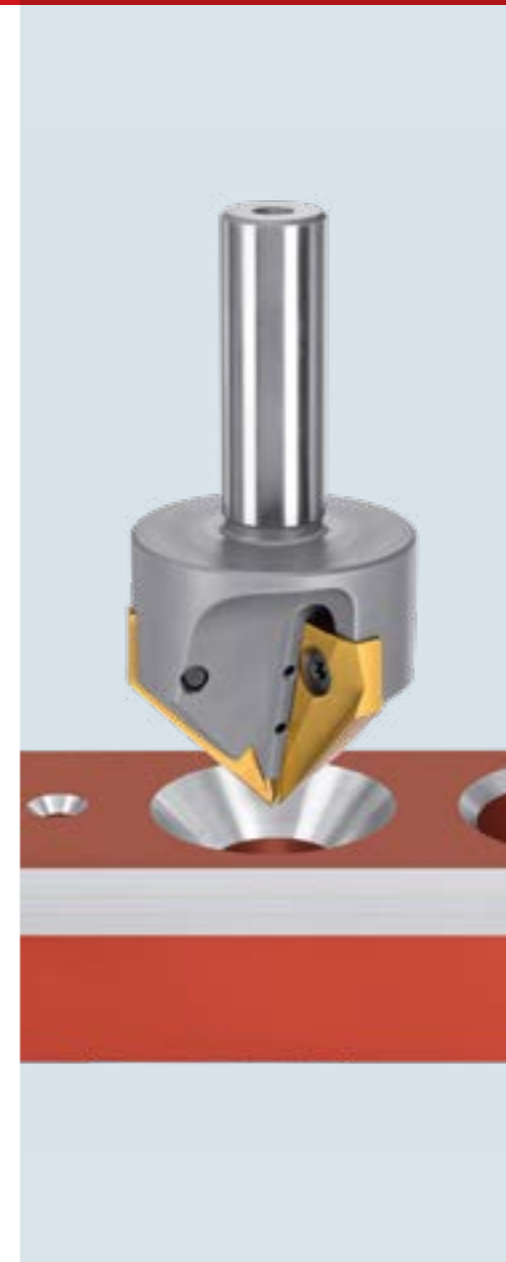

GH-K



Introduction

GH-K – The Chatter-free Countersinking Tool

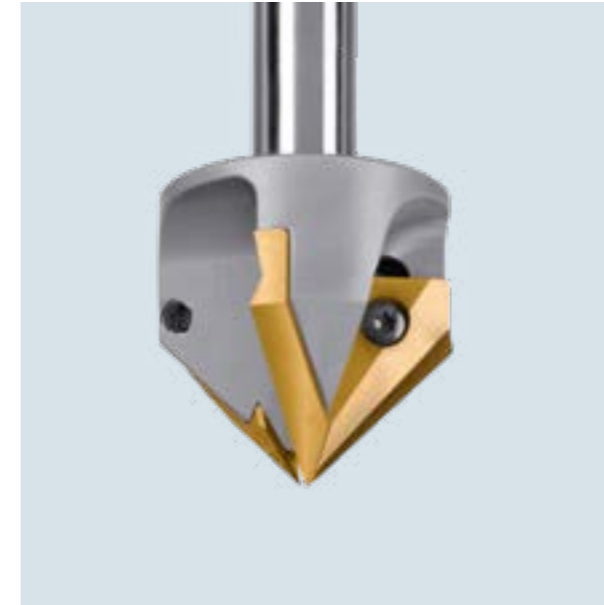

Chatter-free front countersinking of a wide countersink range with one single tool

The GH-K has three exchangeable countersink blades which are precision-ground as a set to achieve unmatched countersink finishes. The tool feeds the coolant through an inner supply duct directly to the blade.

GH-K is unique because of its large countersinking range from diameter Ø3.0 mm to Ø25.0 mm or from diameter Ø4.0 mm to Ø45.0 mm.

Characteristics and Advantages

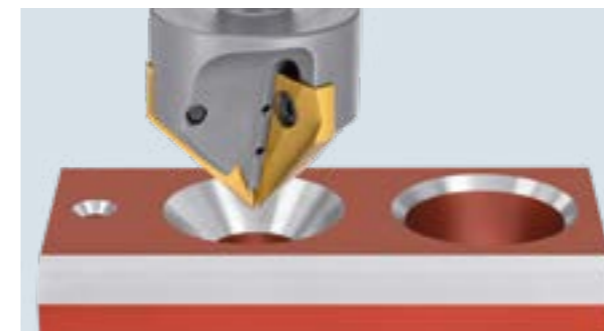

- High-performance countersink tool with three blades for chatter-free countersinking as well as circular cutting.
- Wide countersink range from diameter Ø3.0 mm to Ø25.0 mm or Ø4.0 mm to Ø45.0 mm with one single tool.



- Exchangeable blades that can be re-sharpened, made of carbide provided with a coating.
- Tool body of rugged and high-precision design with coolant.
- Blades that reach to the very tool tip: large countersink range.



- Tools available for 60° and 90° countersinks (screw head counter sinking, rivet head countersinking as per DIN standard).

Tool Description

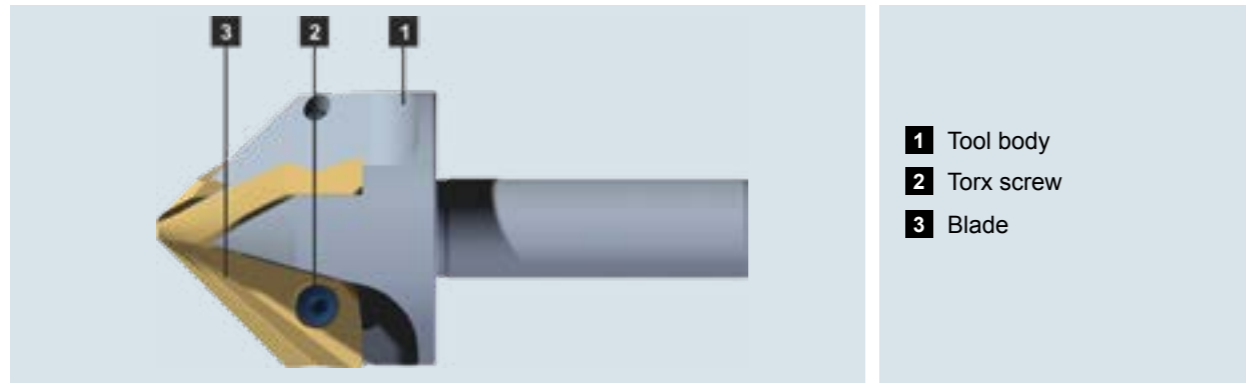

- 1** Tool body
- 2** Torx screw
- 3** Blade

The toolbody made of alloyed heat treated steel together with the carbide blade enable the chatter-free production of countersinks on bores and chamfers on workpiece edges.

Product Selection

GH-K Range Summary

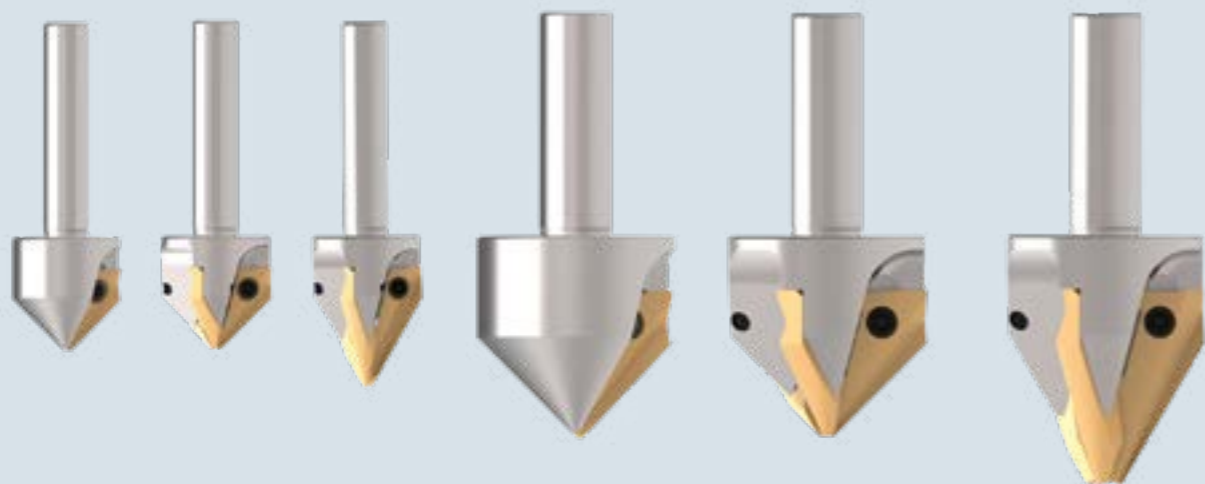

Series	Countersink Angle	Number of blades	Min. bore Ø	Max. countersink Ø
GH-K 25	90°	3	Ø3.0	Ø25.0
	90°	1	Ø3.0	Ø25.0
	60°	3	Ø3.0	Ø25.0
GH-K 45	90°	3	Ø4.0	Ø45.0
	90°	1	Ø4.0	Ø45.0
	60°	3	Ø9.0	Ø45.0

Product Selection

GH-K Tool with 3 Blades

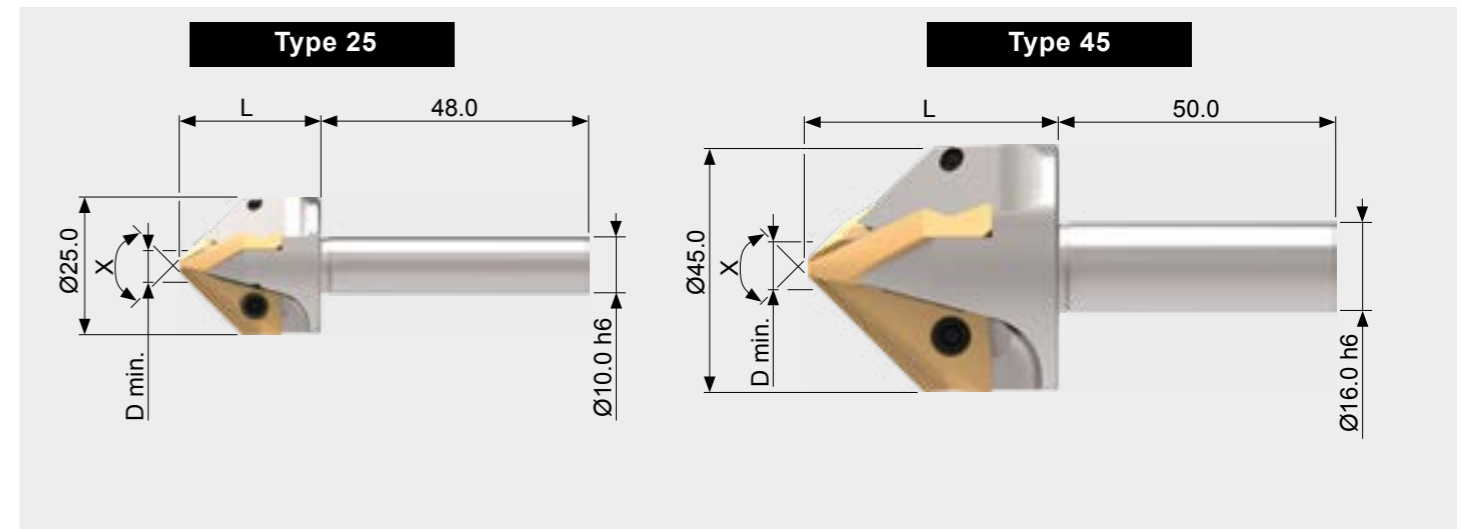

Tool Table

Series	Angle X	D min.	L	Tool without Blade	Spare Parts		
				Part No.	Shim ¹	Torx Screw	Torx Driver
25	90°	3.0	26.0	GH-K-B-0001	GH-K-U 0001	GH-H-S-0008 (T9)	GH-H-S-2014
	60°	3.0	34.0	GH-K-B-0601	GH-K-U 0004	GH-H-S-0008 (T9)	GH-H-S-2014
45	90°	4.0	45.0	GH-K-B-0012	GH-K-U 0002	GH-H-S-0009 (T15)	GH-H-S-2016
	60°	9.0	56.0	GH-K-B-0612	GH-K-U 0005	GH-H-S-0009 (T15)	GH-H-S-2016

¹ Shim to change the cutting geometry 0.05 mm thick. With this geometry change you are able to tune the tool for different materials. These shims have to be placed between blade and tool body.

Blades

Set of Three		Blades
Series	Angle X	Coating T Part No.
25	90°	GH-K-M-0017
	60°	GH-K-M-0617
45	90°	GH-K-M-0018
	60°	GH-K-M-0618

Explanation to coatings

T: Coating for steel, titanium and Inconel

ORDERING INFORMATION:

Other coatings for other materials and/or for increased requirements upon request.

GH-K Tool with 1 Blade

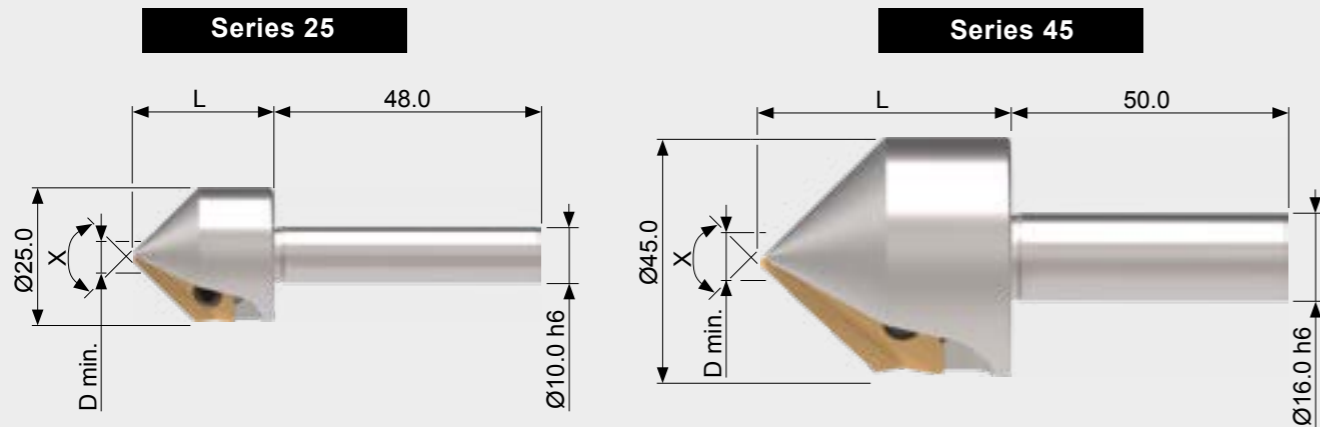

Tool Table

1-Blade-Version				Tool without Blade	Spare Parts		
Series	Angle X	D min.	L	Part No.	Shim ¹	Torx Screw	Torx Driver
25	90°	3.0	26.0	GH-K-B-0010	GH-K-U 0007	GH-H-S-0008 (T9)	GH-H-S-2014
45	90°	4.0	45.0	GH-K-B-0011	GH-K-U 0008	GH-H-S-0009 (T15)	GH-H-S-2016

¹ Shim to change the cutting geometry 0.05 mm thick. With this geometry change you are able to tune the tool for different materials. The shims have to be placed between blade and tool body.

NOTE:
Use the single blade design only with power feed and stable spindle as well as with a rigid set up.

GH-K Blades overview

Single bladed		Blade
Series	Angle	Coating T Part No.
25	90°	GH-K-M-0024
45	90°	GH-K-M-0030

Explanation to coatings
T: Coating for steel, titanium and Inconel

ORDERING INFORMATION:
Other coatings for other materials and/or for increased requirements upon request.

Technical Data and Settings

Cutting Data GH-K

Material	Condition	Tensile stren. (N/mm ²)	Hardness HB	Cutting Speed (m/min.)	Feed (mm/rev.)
Unalloyed steel		<500	<150	30-50	0.05/Blade
Cast steel		500 - 850	150 - 250	30-50	0.05/Blade
Grey cast iron		<500	<150	30-70	0.05/Blade
Ductile cast iron		300 - 800	90 - 240	30-50	0.05/Blade
Low alloy steel	annealed	<850	<250	30-50	0.05/Blade
	tempered	850 - 1000	250 - 300	20-30	0.05/Blade
	tempered	>1000 - 1200	>300 - 350	15-25	0.05/Blade
High alloy steel	annealed	<850	<250	20-30	0.05/Blade
	tempered	850 - 1100	250 - 320	15-25	0.05/Blade
Stainless steel	ferritic	450 - 650	130 - 190	15-25	0.05/Blade
	austenitic	650 - 900	190 - 270	10-20	0.05/Blade
	martensitic	500 - 700	150 - 200	15-25	0.05/Blade
Special alloy (Inconel, titanium, ...)		<1200	<350	10-20	0.05/Blade
Wrought or cast aluminium alloys				30-120	0.05/Blade
Copper alloy	Brass			30-50	0.05/Blade
	Bronze short-chipping			20-30	0.05/Blade
	Bronze long-chipping			15-25	0.05/Blade

WARNING NOTICE

All listed cutting data are standard values only! The cutting values depend on the amount of slope of the uneven bore edge. (i.e. high slope ► low cutting value). The feed also depends on the sloping ratio. In case of hard to machine materials or uneven bore edges, we recommend to apply cutting speeds that are at the lower end of the range for uneven bore edges.

Accessories

Size / Series	Angle	Re-Sharpening Device Part No.
GH-K 25	90°	GH-K-V-0020
GH-K 25	60°	GH-K-V-0023
GH-K 45	90°	GH-K-V-0021
GH-K 45	60°	GH-K-V-0024



VEX Online Information



Product Video
[http://www.heule.com/en/
drilling-and-chamfering-tool/VEX](http://www.heule.com/en/drilling-and-chamfering-tool/VEX)



Case Studies
[www.heule.com/en/case-studies/
?t=100](http://www.heule.com/en/case-studies/?t=100)



Contact Sales Represent.
[www.heule.com/en/contact-sales-
representatives](http://www.heule.com/en/contact-sales-representatives)



Request for Quote Form
www.heule.com/en/Anfrageformular



Manual
[www.heule.com/en/service/
manual/VEX](http://www.heule.com/en/service/manual/VEX)



VEX

Efficient combination of drilling with front and back chamfering in one operation.

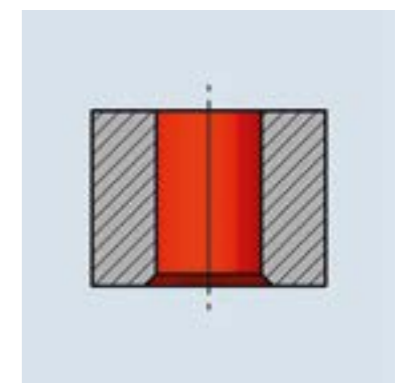
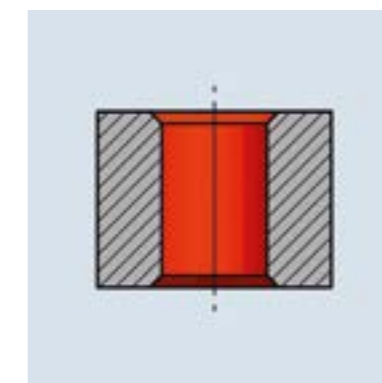



Introduction

VEX – The combined Drilling and Chamfering Tool



Efficient combination of drilling with front and back chamfering in one single pass for bore ranges of Ø5.0 mm - Ø11.49 mm.

VEX revolutionizes the drilling operation by combining the HEULE drill and chamfer technology into **ONE OPERATION**. One single pass and the bore is complete including the chamfer on both bore edges without a tool change or turning the workpiece. Both drill and chamfering blade are made of coated carbide and very easy to be replaced. VEX offers all you need for efficient production.

Characteristics and Advantages

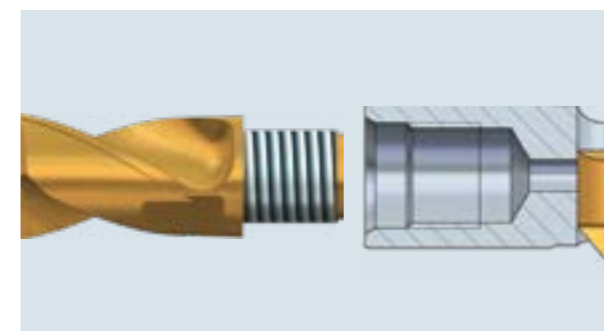

- Reduction of process times by performing two machining operations in **ONE OPERATION**.
- Easy-to-exchange carbide drill inserts with material-specific coatings, with or without inner coolant.

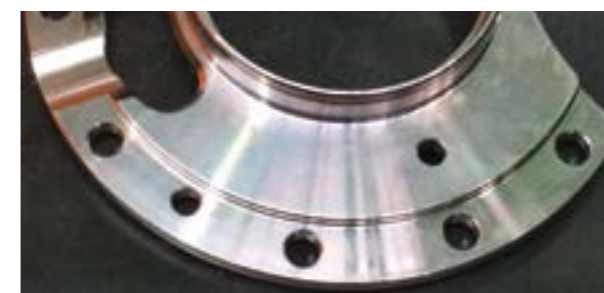

- For bores from diameter Ø5.0 mm to Ø11.5 mm and bore depths up to 2 times bore diameter.
- Manually exchangeable carbide chamfering blades with material-specific coatings.

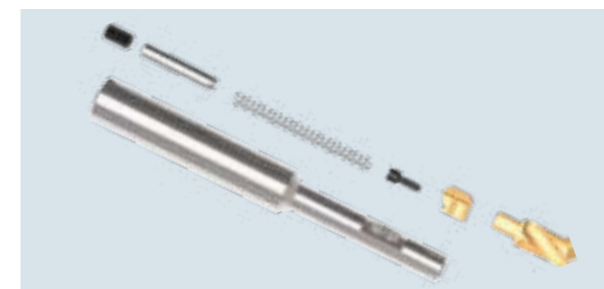

- Short set-up and idle times due to easy handling.

Tool Description

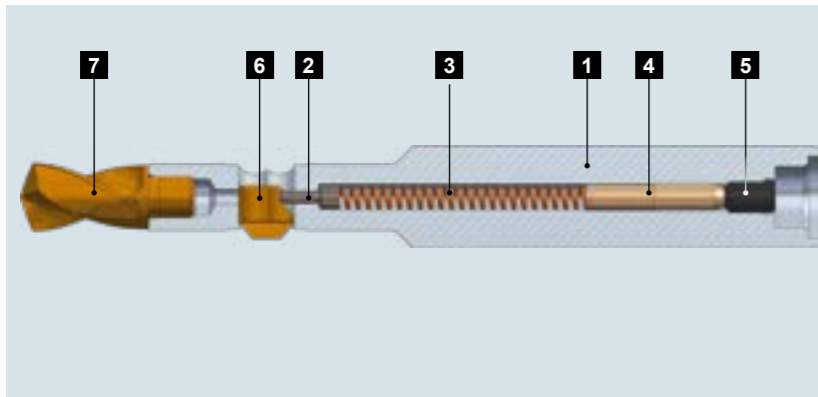

- 1 Tool body
- 2 Control bolt
- 3 Spring
- 4 Distance pin
- 5 Set screw
- 6 SNAP blade
- 7 Drill insert

The **VEX Combi-Tool** unifies a replaceable high performance twist drill with our proven SNAP deburring system. (See description of our SNAP system on page 234).

With this system, it is possible to combine drilling with front and back chamfering in one single operation.

The VEX twist drill incorporates the VEX self-centering high performance cutting geometry. The drill can be re-ground once and re-coated, ensuring best cost-effectiveness.



The **VEX twist drill** is a replaceable high performance drill that is available with or without coolant, manufactured from high quality solid carbide in different coatings.

Internal coolant holes ensure that the coolant is delivered directly onto the end flank and therefore directly into the bore hole (see top of page 215).

The specially developed connecting system ensures robust and accurate connection with the tool body, facilitates good transmission of power and also allows quick and easy replacement of the VEX twist drill.

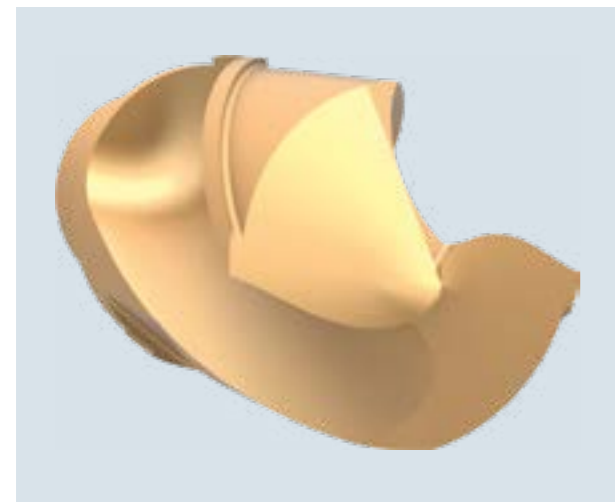

Standard VEX tools are available for a range of bores from $\varnothing 5.0$ mm to $\varnothing 11.49$ mm with bore depths 1xd and 2xd. VEX drill inserts are available from $\varnothing 5.0$ mm in steps of 0.1 mm. Intermediate sizes and other dimensions on request.

The chamfer blades correspond to the SNAP5 Series. They are available from $\varnothing 5.5 \times 90^\circ$ in steps of 0.5 mm, forward and backward cutting or backward-cutting only. Other dimensions available on request.

Function Principle

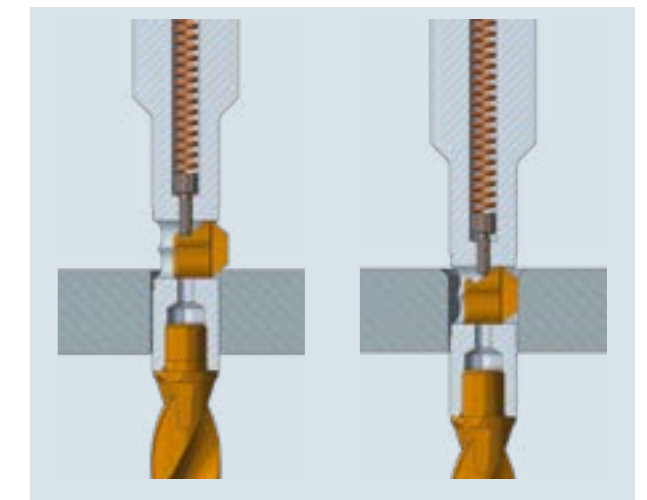
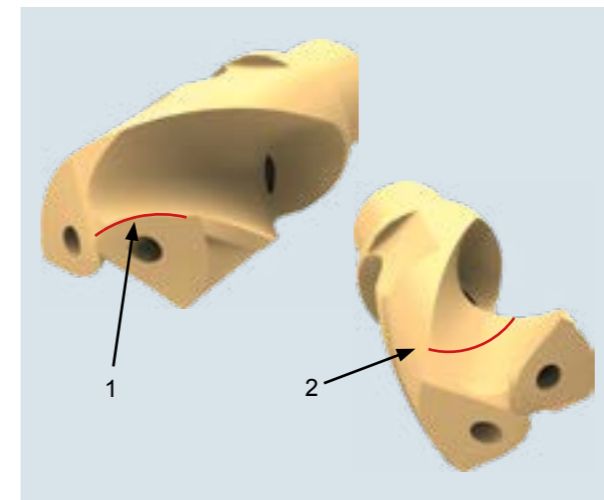

The patented VEX cutting geometry guarantees a high drilling performance with short chips. Due to the convex cutting edge (1), which merges into a concave chip angle (2) short chips are guaranteed even when machining long chipping material. A large chip channel also optimizes swarf evacuation.

The SNAP chamfering blade is held by a spring-loaded control bolt in the tool body allowing it to move. The specially-ground SNAP blade for front and back or only back-cutting produces the required chamfer in **ONE OPERATION**. As soon as the defined chamfer thickness has been achieved, the SNAP radially enters the tool body. The chamfer thickness and angle are geometrically defined on the SNAP blade and can only be modified by inserting a different SNAP blade.

Process Steps Description

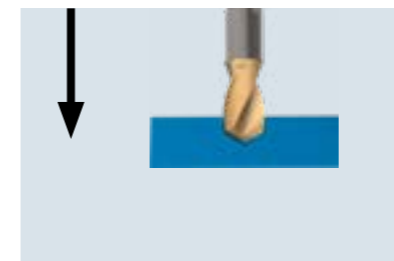

To do the drilling work, the tool is equipped with a screw-on high-performance helical drill bit.

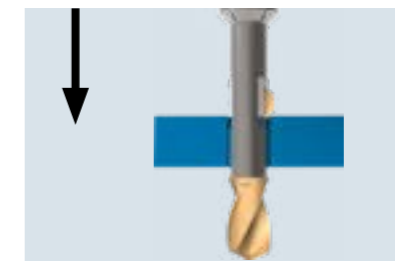

Drilling is followed by front and back chamfering using the integrated SNAP chamfering system. The specially ground SNAP blade for front and back or only back cutting produces the required chamfer.

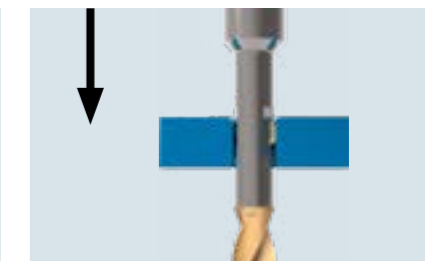

As soon as the defined chamfer thickness has been achieved, the SNAP radially enters the tool body.

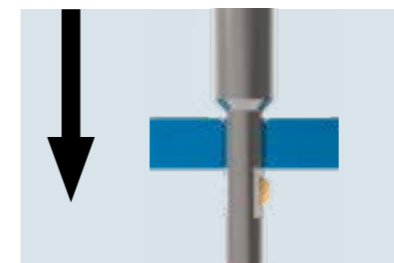

When it exits the bore, the SNAP blade is returned by the spring-loaded control bolt to the initial position.

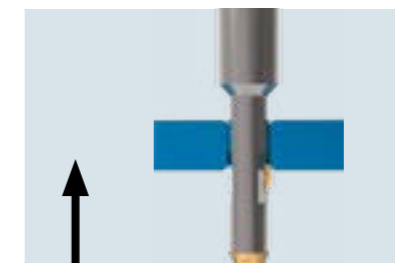

Without stopping the spindle or changing the sense of rotation, the tool produces the back chamfer on its way back.

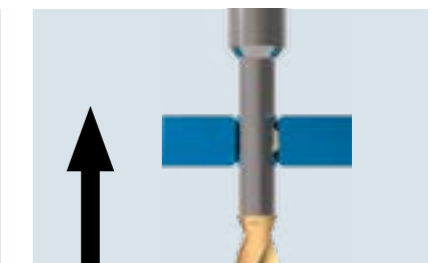

As soon as the back chamfer is completed, the tool can exit the workpiece in rapid traverse.

VEX Range Summary



Series	Bore range	Bore depth 1 x d	Bore depth 2 x d	Chamfer max.
B	Ø 5.00 – Ø 5.49	5.5	11.0	Ø 7.0
	Ø 5.50 – Ø 5.99	6.0	12.0	Ø 7.5
C	Ø 6.00 – Ø 6.49	6.5	13.0	Ø 8.0
	Ø 6.50 – Ø 6.99	7.0	14.0	Ø 8.5
D	Ø 7.00 – Ø 7.49	7.5	15.0	Ø 9.0
	Ø 7.50 – Ø 7.99	8.0	16.0	Ø 9.5
	Ø 8.00 – Ø 8.49	8.5	17.0	Ø 10.0
E	Ø 8.50 – Ø 8.99	9.0	18.0	Ø 10.5
	Ø 9.00 – Ø 9.49	9.5	19.0	Ø 11.0
	Ø 9.50 – Ø 9.99	10.0	20.0	Ø 11.5
	Ø 10.00 – Ø 10.49	10.5	21.0	Ø 12.0
F	Ø 10.50 – Ø 10.99	11.0	22.0	Ø 12.5
	Ø 11.00 – Ø 11.49	11.5	23.0	Ø 13.0

Ø 11.50 and larger upon request

Part No.:
Tool

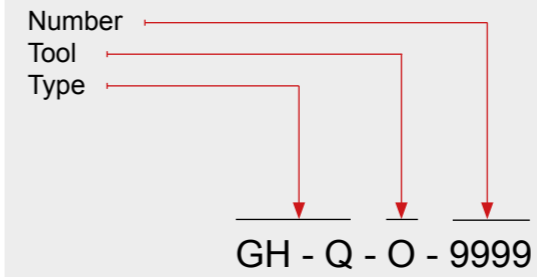

Tool type
Within the VEX tool range there are different tool sizes available. The tool types B / C / D / E / F are divided in so-called Series and show the partition of the tool sizes to the bore-Ø.

Tool size
The tool size is defined by the bore-Ø. Tool-Ø, bore-Ø and chamfer-Ø can be looked up in the tables.

Bore depth
The required bore depth defines the selection of the twist drill insert. VEX offers the possibility of 1xd and 2xd. This means that if the required bore depth exceeds the bore diameter by up to 100% maximum the 2xd-drill insert is the right choice.

Drill bits with internal coolant
Helical drill bits with internal coolant are available from Ø6.0 mm on only (please refer to page 220 and 224).

Clamping system
As standard, all tool will be manufactured with a cylindrical shank. Weldon / Whistle Notch clamping systems can be ordered upon request - but are not available from stock.
- HB = Weldon
- HE = Whistle Notch

- Example: GH-Q-O-4055-HB

Part No.:
Helical Drill Bit

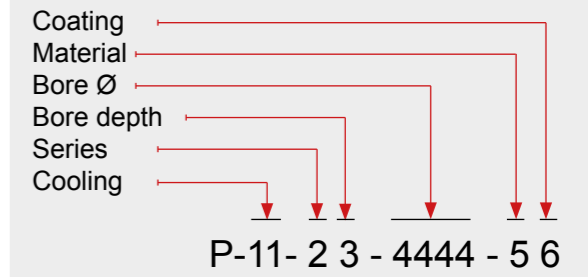

11 Cooling

Without internal cool.	S (from Ø5.0 mm)
With internal coolant	SK (from Ø6.0 mm)

2 Series

Bore range Ø d	Series
5.00 – 5.99	B
6.00 – 6.99	C
7.00 – 8.49	D
8.50 – 10.49	E
10.50 – 11.49	F

3 Bore depth T

1 x d	2
2 x d	4

4444 Bore diameter d
Please insert the bore diameter here. Examl: Ø 9.50 = 0950 standard per 0.1 mm

5 Cutting material

Carbide	1
---------	---

6 Coating¹

Coating for alloyed steel, titanium and Inconel	A
Coating for aluminium alloys only	D

¹) Alternative coatings upon request

Order example:
Material: Steel
Bore Ø: 9.5 mm
Coating: A
Bore depth T: 9.5 mm (1 x d)
Solution:
Part Number: **P-S-E2-0950-1A**

VEX Combi Ø5.0 to 11.0 mm **without** Internal Coolant – Bore Depth 1 x d

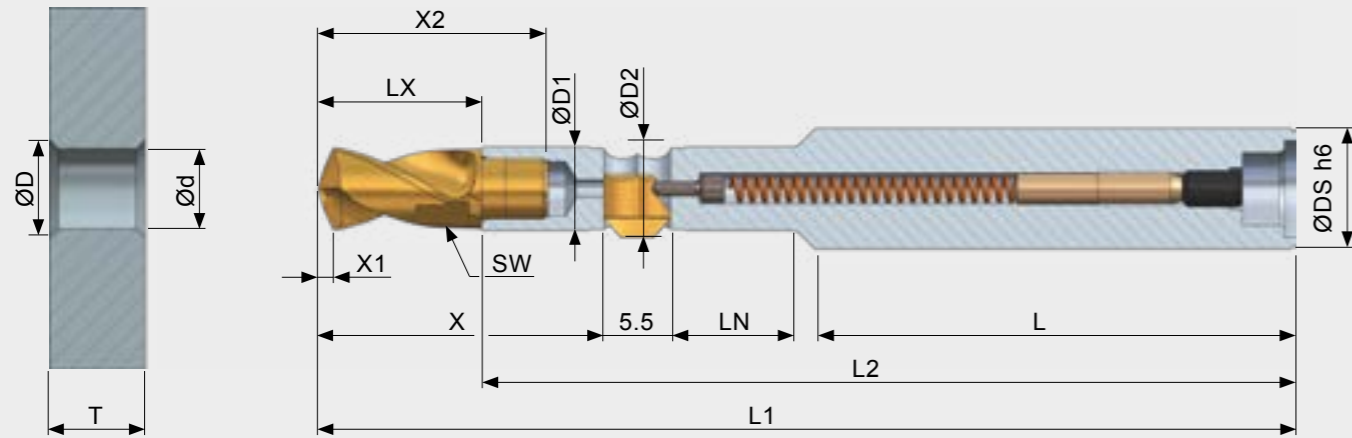

Tool Table

Bore range Ød	Bore depth T	Series	ØD	ØD1	ØD2	ØDS	L	L1	L2	LN	X	X1	Part No.	Tool without Drill Bit without Blade
5.00-5.49	5.5	B	Chamfer-Ø D max. = Bore-Ø d min. + 2.0 mm ØD2 = Ød + 0.6 mm	4.9	8.0	36.0	70.5	60.3	8.1	18.9	1.0	GH-Q-O-4000		
5.50-5.99	6.0	B		5.4	8.0	36.0	71.6	60.5	8.6	19.8	1.1	GH-Q-O-4001		
6.00-6.49	6.5	C		5.9	10.0	40.0	77.7	66.0	9.1	20.6	1.2	GH-Q-O-4002		
6.50-6.99	7.0	C		6.4	10.0	40.0	78.9	66.2	9.6	21.6	1.3	GH-Q-O-4003		
7.00-7.49	7.5	D		6.9	10.0	40.0	81.4	67.8	10.9	23.8	1.4	GH-Q-O-4004		
7.50-7.99	8.0	D		7.4	10.0	40.0	82.4	68.0	10.6	24.6	1.5	GH-Q-O-4005		
8.00-8.49	8.5	D		7.9	12.0	45.0	89.5	74.3	11.9	25.4	1.6	GH-Q-O-4006		
8.50-8.99	9.0	E		8.4	12.0	45.0	90.9	74.8	11.6	26.6	1.7	GH-Q-O-4007		
9.00-9.49	9.5	E		8.9	12.0	45.0	91.9	75.0	12.1	27.4	1.8	GH-Q-O-4008		
9.50-9.99	10.0	E		9.4	12.0	45.0	93.1	75.3	12.6	28.3	1.9	GH-Q-O-4009		
10.00-10.49	10.5	E		9.9	14.0	45.0	95.1	76.5	13.1	29.1	1.9	GH-Q-O-4010		
10.50-10.99	11.0	F		10.4	14.0	45.0	96.4	77.3	13.6	30.1	2.1	GH-Q-O-4011		
11.00-11.49	11.5	F		10.9	14.0	45.0	97.4	77.5	14.1	30.9	2.1	GH-Q-O-4012		

ORDERING INFORMATION:

For tools and tool bodies with Weldon (-HB) or Whistle-Notch-Shank (-HE), please add -HB or -HE at the end of the part number (Order example: GH-Q-O-4000-HB).

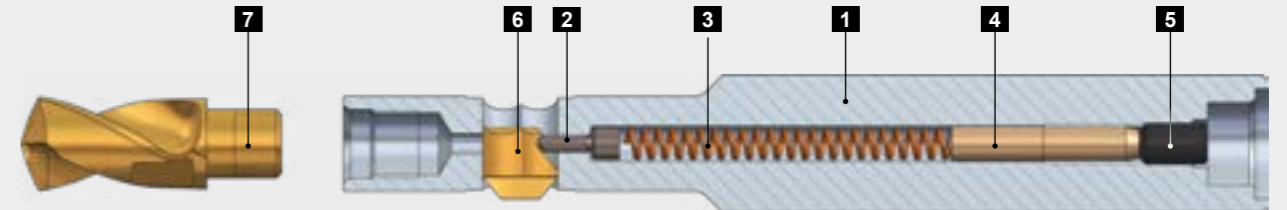

Spare Parts

Pos.	Description	Part No.
1	Tool body	see page 232
2	Control bolt Ø1.2	GH-Q-E-0008
3	Spring Ø2.35xØ0.35x30.0	GH-H-F-0019
4	Distance pin Bore range 5.00 - 5.99 Distance pin Bore range 6.00 - 7.99 Distance pin Bore range 8.00 - 11.49	GH-Q-E-0052 GH-Q-E-0043 GH-Q-E-0048
5	Set screw M3x5.0 DIN913 Wrench for Pos. 5 ¹⁾	GH-H-S-0127 GH-H-S-2101
6	SNAP chamfer blade	see page 236
7	VEX helical drill bit Torque spanner for Pos. 7 ¹⁾	see below see page 233

¹⁾ Fork wrench for Pos. 5 and Pos. 7 to be ordered separately.

Helical Drill Bit

Dimension Table

Bore range Ød	Bore depth T	Series	X1	LX	X2	SW	Ncm	Helical Drill Bit Part No.
5.00-5.49	5.5	B	1.00	10.2	14.7	4.0	170	Refer to page 217 for composing the part number
5.50-5.99	6.0	B	1.10	11.1	15.6	4.0	170	
6.00-6.49	6.5	C	1.20	11.7	16.2	5.0	250	
6.50-6.99	7.0	C	1.30	12.7	17.2	5.0	250	
7.00-7.49	7.5	D	1.35	13.6	19.1	6.0	400	
7.50-7.99	8.0	D	1.45	14.4	19.9	6.0	400	
8.00-8.49	8.5	D	1.55	15.2	20.7	7.0	400	
8.50-8.99	9.0	E	1.65	16.1	21.6	7.0	600	
9.00-9.49	9.5	E	1.75	16.9	22.4	8.0	600	
9.50-9.99	10.0	E	1.85	17.8	23.3	8.0	600	
10.00-10.49	10.5	E	1.90	18.6	24.1	9.0	600	
10.50-10.99	11.0	F	2.10	19.1	24.6	9.0	600	
11.00-11.49	11.5	F	2.20	19.9	25.4	9.0	600	

SNAP Chamfer Blade

The explanations about the SNAP chamfering technology as well as for the selection of the suitable blades are listed on page 234.

VEX Combi Ø6.0 to 11.0 mm with Internal Coolant – Bore Depth 1 x d

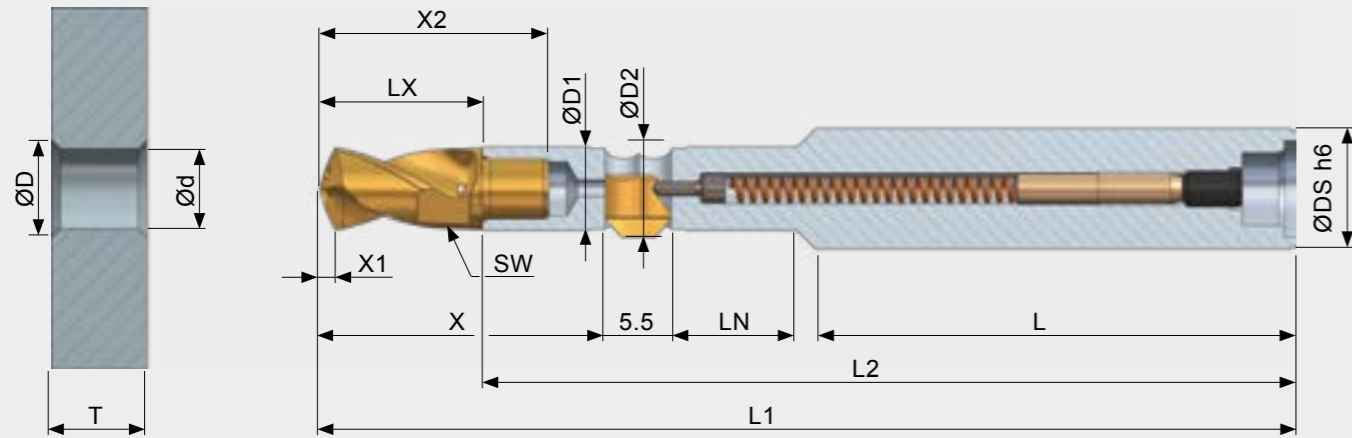

Tool Table

Bore range Ød	Bore depth T	Series	ØD	ØD1	ØD2	ØDS	L	L1	L2	LN	X	X1	Part No.	Tool without Drill Bit without Blade
6.00-6.49	6.5	C	5.9	10.0	40.0	77.7	66.0	9.1	20.6	1.2			GH-Q-O-4022	
6.50-6.99	7.0	C	6.4	10.0	40.0	78.9	66.2	9.6	21.6	1.3			GH-Q-O-4023	
7.00-7.49	7.5	D	6.9	10.0	40.0	81.4	67.8	10.9	23.8	1.4			GH-Q-O-4024	
7.50-7.99	8.0	D	7.4	10.0	40.0	82.4	68.0	10.6	24.6	1.5			GH-Q-O-4025	
8.00-8.49	8.5	D	7.9	12.0	45.0	89.5	74.3	11.9	25.4	1.6			GH-Q-O-4026	
8.50-8.99	9.0	E	8.4	12.0	45.0	90.9	74.8	11.6	26.6	1.7			GH-Q-O-4027	
9.00-9.49	9.5	E	8.9	12.0	45.0	91.9	75.0	12.1	27.4	1.8			GH-Q-O-4028	
9.50-9.99	10.0	E	9.4	12.0	45.0	93.1	75.3	12.6	28.3	1.9			GH-Q-O-4029	
10.00-10.49	10.5	E	9.9	14.0	45.0	95.1	76.5	13.1	29.1	1.9			GH-Q-O-4030	
10.50-10.99	11.0	F	10.4	14.0	45.0	96.4	77.3	13.6	30.1	2.1			GH-Q-O-4031	
11.00-11.49	11.5	F	10.9	14.0	45.0	97.4	77.5	14.1	30.9	2.1			GH-Q-O-4032	

Chamfer-Ø max. = Bore-Ø d min. + 2,0 mm

ØD2 = ØD + 0.6 mm

ORDERING INFORMATION:

For tools and tool bodies with Weldon (-HB) or Whistle-Notch shank (-HE), please add -HB or -HE at the end of the part number (Order example: GH-Q-O-4022-HB).

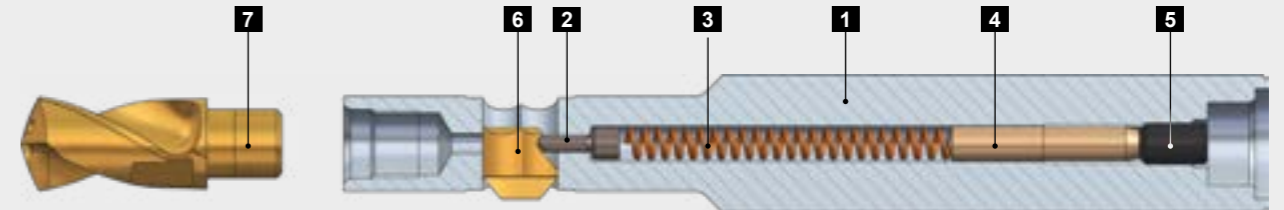

Spare Parts

Pos.	Description	Part No.
1	Tool body	see page 232
2	Control bolt Ø1.2	GH-Q-E-0008
3	Spring Ø2.35xØ0.35x30.0	GH-H-F-0019
4	Distance pin Bore range 6.00 - 7.99 Distance pin Bore range 8.00 - 11.49	GH-Q-E-0043 GH-Q-E-0048
5	Set screw M3x5.0 DIN913 Wrench for Pos. 5*	GH-H-S-0127 GH-H-S-2101
6	SNAP chamfering blade	see page 236
7	VEX helical drill bit Torque spanner for Pos. 7*	see below see page 233

* Fork wrench for Pos. 5 and Pos. 7 to be ordered separately.

Helical Drill Bit

Dimension Table

Bore range Ød	Bore depth T	Series	X1	LX	X2	SW	Ncm	Part No.
6.00-6.49	6.5	C	1.20	11.7	16.2	5.0	250	
6.50-6.99	7.0	C	1.30	12.7	17.2	5.0	250	
7.00-7.49	7.5	D	1.35	13.6	19.1	6.0	400	
7.50-7.99	8.0	D	1.45	14.4	19.9	6.0	400	
8.00-8.49	8.5	D	1.55	15.2	20.7	7.0	400	
8.50-8.99	9.0	E	1.65	16.1	21.6	7.0	600	
9.00-9.49	9.5	E	1.75	16.9	22.4	8.0	600	
9.50-9.99	10.0	E	1.85	17.8	23.3	8.0	600	
10.00-10.49	10.5	E	1.90	18.6	24.1	9.0	600	
10.50-10.99	11.0	F	2.10	19.1	24.6	9.0	600	
11.00-11.49	11.5	F	2.20	19.9	25.4	9.0	600	

Refer to page 217 for composing the part number

SNAP Chamfer Blades

The explanations about the SNAP chamfering technology as well as for the selection of the suitable blades are listed on page 234.

VEX Combi Ø5.0 - 11.0 mm **without** Internal Coolant – Bore Depth 2 x d

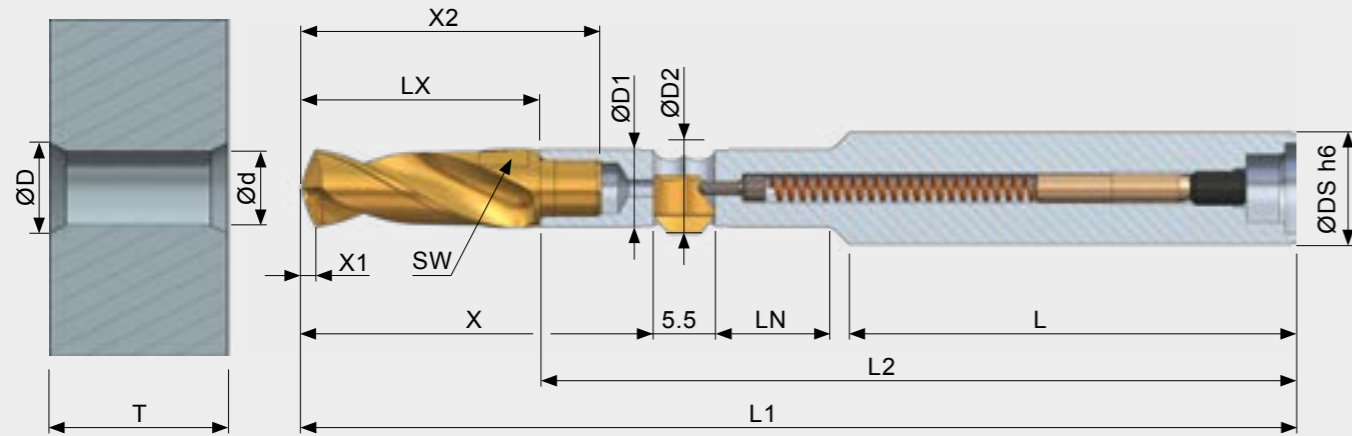

Tool Table

Bore range Ød	Bore depth T	Series	ØD	ØD1	ØD2	ØDS	L	L1	L2	LN	X	X1	Part No.	Tool without Drill Bit without Blade
5.00-5.49	11.0	B	Chamfer-Ø D max. = Bore-Ø d min. + 2.0 mm	4.9	ØD2 = ØD + 0.6 mm	8.0	36.0	81.8	65.8	13.6	24.7	1.0	GH-Q-O-4050	
5.50-5.99	12.0	B		5.4		8.0	36.0	82.9	65.5	13.6	26.1	1.1	GH-Q-O-4051	
6.00-6.49	13.0	C		5.9		10.0	40.0	90.8	72.4	15.6	27.3	1.2	GH-Q-O-4052	
6.50-6.99	14.0	C		6.4		10.0	40.0	93.3	73.3	16.7	28.9	1.3	GH-Q-O-4053	
7.00-7.49	15.0	D		6.9		10.0	40.0	96.7	75.3	17.9	31.7	1.4	GH-Q-O-4054	
7.50-7.99	16.0	D		7.4		10.0	40.0	98.7	76.0	18.6	32.9	1.5	GH-Q-O-4055	
8.00-8.49	17.0	D		7.9		12.0	45.0	106.7	82.7	19.8	34.2	1.6	GH-Q-O-4056	
8.50-8.99	18.0	E		8.4		12.0	45.0	109.2	83.8	20.6	35.9	1.7	GH-Q-O-4057	
9.00-9.49	19.0	E		8.9		12.0	45.0	113.2	86.5	23.6	37.2	1.8	GH-Q-O-4058	
9.50-9.99	20.0	E		9.4		12.0	45.0	113.4	85.3	22.6	38.6	1.9	GH-Q-O-4059	
10.00-10.49	21.0	E		9.9		14.0	45.0	115.1	87.0	23.6	39.9	1.9	GH-Q-O-4060	
10.50-10.99	22.0	F		10.4		14.0	45.0	118.5	88.3	24.6	41.2	2.1	GH-Q-O-4061	
11.00-11.49	23.0	F		10.9		14.0	45.0	120.5	89.0	25.6	42.5	2.1	GH-Q-O-4062	

ORDERING INFORMATION:

For tools and tool bodies with Weldon (-HB) or Whistle-Notch shank (-HE), please add -HB or -HE at the end of the part number (Order example: GH-Q-O-4022-HB).

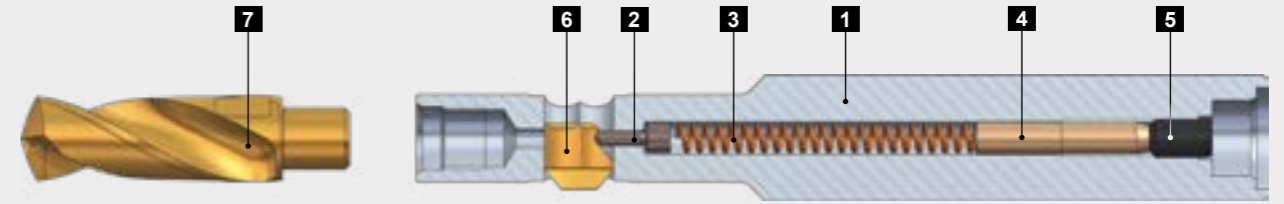

Spare Parts

Pos.	Description	Part No.
1	Tool body	see page 232
2	Control bolt Ø1.2	GH-Q-E-0008
3	Spring Ø2.35xØ0.35x30.0	GH-H-F-0019
4	Distance pin Bore range 5.00 - 5.49 Distance pin Bore range 5.50 - 7.99 Distance pin Bore range 8.00 - 11.49	GH-Q-E-0043 GH-Q-E-0048 GH-Q-E-0039
5	Set screw M3x5.0 DIN913 Wrench zu Pos. 5 ¹⁾	GH-H-S-0127 GH-H-S-2101
6	SNAP chamfering blade	see page 236
7	VEX helical drill bit Torque spanner for Pos. 7 ¹⁾	see below see page 233

¹⁾ Fork wrench for Pos. 5 and Pos. 7 to be ordered separately.

Helical Drill Bit

Dimension table

Bore range Ød	Bore depth T	Series	X1	LX	X2	SW	Ncm	Helical Drill Bit Part No.
5.00-5.49	11.0	B	1.00	16.0	20.5	4.0	170	Refer to page 217 for composing the part number
5.50-5.99	12.0	B	1.10	17.4	21.9	4.0	170	
6.00-6.49	13.0	C	1.20	18.4	22.9	5.0	250	
6.50-6.99	14.0	C	1.30	20.0	24.5	5.0	250	
7.00-7.49	15.0	D	1.35	21.4	26.9	6.0	400	
7.50-7.99	16.0	D	1.45	22.7	28.2	6.0	400	
8.00-8.49	17.0	D	1.55	24.0	29.5	7.0	400	
8.50-8.99	18.0	E	1.65	25.4	30.9	7.0	600	
9.00-9.49	19.0	E	1.75	26.7	32.2	8.0	600	
9.50-9.99	20.0	E	1.85	28.1	33.6	8.0	600	
10.00-10.49	21.0	E	1.90	29.4	34.9	9.0	600	
10.50-10.99	22.0	F	2.10	30.2	35.7	9.0	600	
11.00-11.49	23.0	F	2.20	31.5	37.0	9.0	600	

SNAP Chamfer Blades

The explanations about the SNAP chamfering technology as well as for the selection of the suitable blades are listed on page 234.

VEX Combi Ø6.0 - 11.0 mm with Internal Cooling – Bore Depth 2 x d

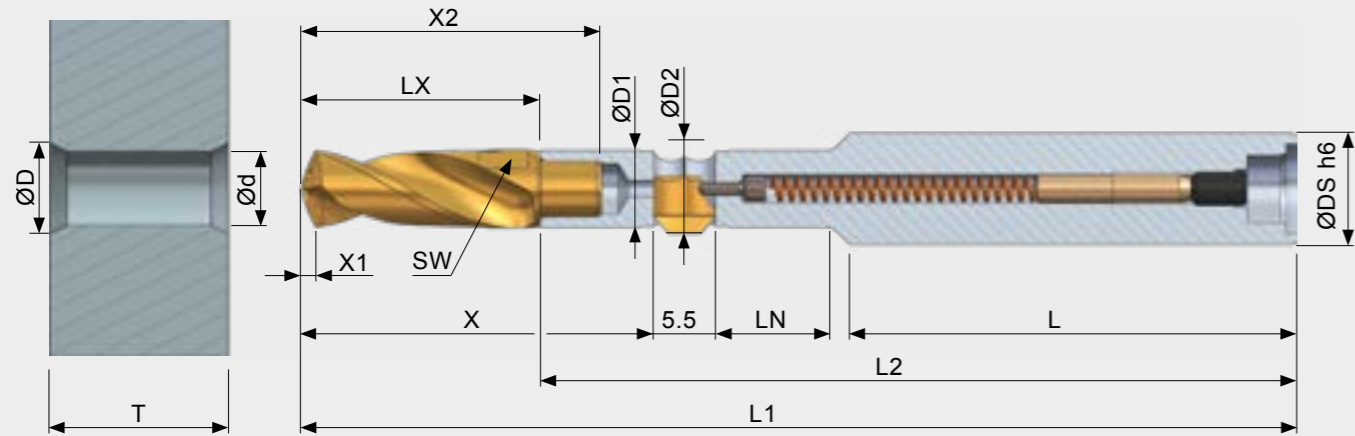

Tool Table

Bore range Ød	Bore depth T	Series	ØD	ØD1	ØD2	ØDS	L	L1	L2	LN	X	X1	Tool without Drill Bit without Blade
6.00-6.49	13.0	C		5.9		10.0	40.0	90.8	72.4	15.6	27.3	1.2	Part No.
6.50-6.99	14.0	C		6.4		10.0	40.0	93.3	73.3	16.7	28.9	1.3	
7.00-7.49	15.0	D		6.9		10.0	40.0	96.7	75.3	17.9	31.7	1.4	
7.50-7.99	16.0	D		7.4		10.0	40.0	98.7	76.0	18.6	32.9	1.5	
8.00-8.49	17.0	D		7.9		12.0	45.0	106.7	82.7	19.8	34.2	1.6	
8.50-8.99	18.0	E		8.4		12.0	45.0	109.2	83.8	20.6	35.9	1.7	
9.00-9.49	19.0	E		8.9		12.0	45.0	113.2	86.5	23.6	37.2	1.8	
9.50-9.99	20.0	E		9.4		12.0	45.0	113.4	85.3	22.6	38.6	1.9	
10.00-10.49	21.0	E		9.9		14.0	45.0	115.1	87.0	23.6	39.9	1.9	
10.50-10.99	22.0	F		10.4		14.0	45.0	118.5	88.3	24.6	41.2	2.1	
11.00-11.49	23.0	F		10.9		14.0	45.0	120.5	89.0	25.6	42.5	2.2	

Chamfer-Ø D max. = Bore-Ø d min. + 2.0 mm
 ØD2 = ØD + 0.6 mm

ORDERING INFORMATION:

For tools and tool bodies with Weldon (-HB) or Whistle-Notch shank (-HE), please add -HB or -HE at the end of the part number (Order example: GH-Q-O-4072-HB).

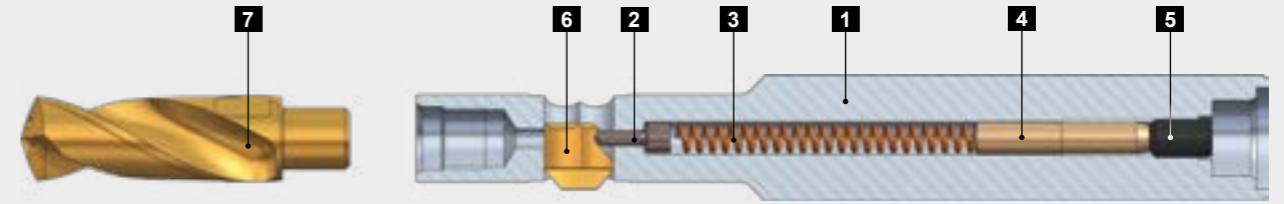

Spare Parts

Pos.	Description	Part No.
1	Tool Body	see page 232
2	Control Bolt Ø1.2	GH-Q-E-0008
3	Spring Ø2.35xØ0.35x30.0	GH-H-F-0019
4	Distance pin Bore range 6.00 - 7.99 Distance pin Bore range 8.00 - 11.49	GH-Q-E-0048 GH-Q-E-0039
5	Set screw M3x5.0 DIN913 Wrench for Pos. 5 ¹	GH-H-S-0127 GH-H-S-2101
6	SNAP chamfer blade	see page 236
7	VEX helical drill bit Torque Spanner for Pos. 7 ¹	see below see page 233

¹⁾ Fork wrench for Pos. 5 and Pos. 7 to be ordered separately.

Helical Drill Bit

Dimension table

Bore range Ød	Bore depth T	Series	X1	LX	X2	SW	Ncm	Helical Drill Bit
6.00-6.49	6.5	C	1.20	11.7	16.2	5.0	250	Part No.
6.50-6.99	7.0	C	1.30	12.7	17.2	5.0	250	
7.00-7.49	7.5	D	1.35	13.6	19.1	6.0	400	
7.50-7.99	8.0	D	1.45	14.4	19.9	6.0	400	
8.00-8.49	8.5	D	1.55	15.2	20.7	7.0	400	
8.50-8.99	9.0	E	1.65	16.1	21.6	7.0	600	
9.00-9.49	9.5	E	1.75	16.9	22.4	8.0	600	
9.50-9.99	10.0	E	1.85	17.8	23.3	8.0	600	
10.00-10.49	10.5	E	1.90	18.6	24.1	9.0	600	
10.50-10.99	11.0	F	2.10	19.1	24.6	9.0	600	
11.00-11.49	11.5	F	2.20	19.9	25.4	9.0	600	

Refer to page 217 for composing the part number

SNAP Chamfer Blades

The explanations about the SNAP chamfering technology as well as for the selection of the suitable blades are listed on page 234.

Technical Data and Settings

Cutting Data Drilling VEX¹

Recommended cutting data for helical drills for maximum bore depth < 2xd

Material	Condition	Tensile stren.	Hardness	Cutting speed	Feed
		(N/mm ²)	HB	(m/min)	(mm/rev.)
Unalloyed steel		<500	<150	100-130	0.15-0.25
Cast steel		500 - 850	150 - 250	90-110	0.15-0.25
Grey cast iron		<500	<150	90-180	0.20-0.35
Ductile cast iron		300 - 800	90 - 240	90-160	0.15-0.30
Low alloy steel	annealed	<850	<250	80-130	0.15-0.25
	tempered	850 - 1000	250 - 300	70-110	0.15-0.25
	tempered	>1000 - 1200	>300 - 350	40-70	0.12-0.20
High alloy steel	annealed	<850	<250	40-70	0.12-0.20
	tempered	850 - 1100	250 - 320	35-50	0.12-0.15
Stainless steel	ferritic	450 - 650	130 - 190	30-50	0.08-0.12
	austenitic	650 - 900	190 - 270	30-40	0.08-0.12
	martensitic	500 - 700	150 - 200	20-30	0.08-0.12
Special alloy (Inconel, titanium, ...)		<1200	<350	20-25	0.06-0.10
Wrought or cast aluminium alloys				120-250	0.25-0.35
Copper alloy	Brass			140-200	0.25-0.35
	Bronze short-chipping			60-100	0.20-0.30
	Bronze long-chipping			40-60	0.15-0.25

¹⁾ Cutting data for deburring / chamfering (SNAP system) please see on page 234.

WARNING NOTICE

All listed cutting data are standard values only! The cutting values depend on the amount of slope of the uneven bore edge. (i.e. high slope ► low cutting value). The feed also depends on the sloping ratio. In case of hard to machine materials or uneven bore edges, we recommend to apply cutting speeds that are at the lower end of the range for uneven bore edges.

Programming Information VEX

It is not necessary to change the direction of rotation or to stop the spindle during the full process.



Rapid traverse of the tool to just above the top of the workpiece. Pay attention to the clearance distance.

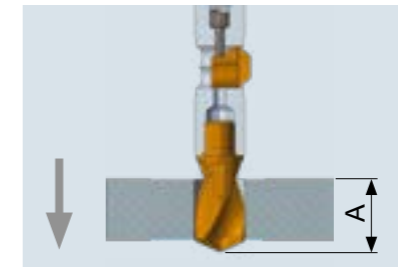

In forward linear feed the bore is produced. Continue in linear feed until the drill insert is completely clear of the bore.

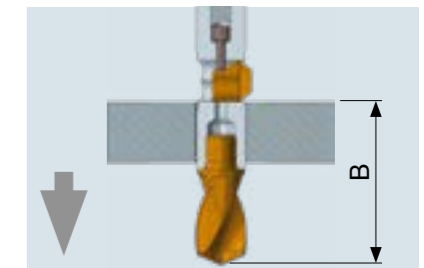

Position tool with SNAP blade in rapid feed, forward slightly above the top material surface of bore or burr.

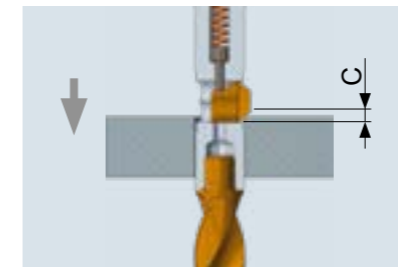

In linear feed forward, the chamfer is generated. Continue in linear feed until the blade is completely retracted into the tool.

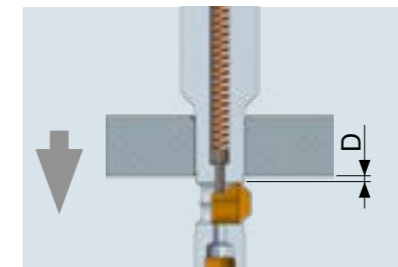

The tool can be passed through the hole in rapid feed forward until the SNAP blade is clear of the hole and fully extended.

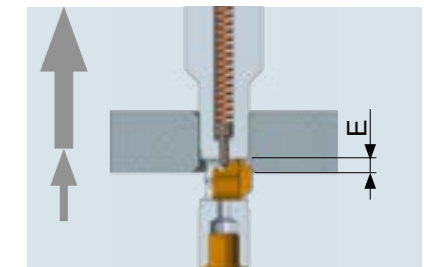

The back chamfer is machined by linear feed backward (no change of spindle direction). As soon as the SNAP blade is completely retracted into the tool, the tool can travel out of the hole in rapid feed backward.

Dimension Table to Programming Information

Bore depth	A		B		C		D		E	
	1xd	2xd	1xd	2xd	1xd	2xd	1xd	2xd	1xd	2xd
Tool type										
Series B 5.0 ¹	5.5	11.0	17.9	23.7	21.9	27.7	25.4	31.2	21.9	27.7
Series B 5.5 ¹	6.0	12.0	18.8	25.1	22.8	29.1	26.3	32.6	22.8	29.1
Series C 6.0	6.5	13.0	19.6	26.3	23.6	30.3	27.1	33.8	23.6	30.3
Series C 6.5	7.0	14.0	20.6	27.9	24.6	31.9	28.1	35.4	24.6	31.9
Series D 7.0	7.5	15.0	22.8	30.7	26.8	34.7	30.3	38.1	26.8	34.7
Series D 7.5	8.0	16.0	23.6	31.9	27.6	35.9	31.1	39.4	27.6	35.9
Series D 8.0	8.5	17.0	24.4	33.2	28.4	37.2	31.9	40.7	28.4	37.2
Series E 8.5	9.0	18.0	25.6	34.9	29.6	38.9	33.1	42.4	29.6	38.9
Series E 9.0	9.5	19.0	26.4	36.2	30.4	40.2	33.9	43.7	30.4	40.2
Series E 9.5	10.0	20.0	27.3	37.6	31.3	41.6	34.8	45.5	31.3	41.6
Series E 10.0	10.5	21.0	28.1	38.9	32.1	42.9	35.6	46.4	32.1	42.9
Series E 10.5	11.0	22.0	29.1	40.2	33.1	44.2	36.6	47.7	33.1	44.2
Series F 11.0	11.5	23.0	29.9	41.5	33.9	45.5	37.4	49.0	33.9	45.5

¹⁾ Available only without internal cooling. VEX with internal cooling starts from bore-Ø 6.00 mm.

Application Range



Drilling on even machined surfaces.

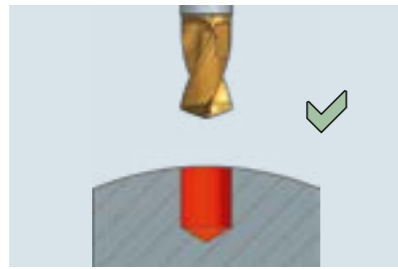

Drilling on central or convex surfaces.¹⁾

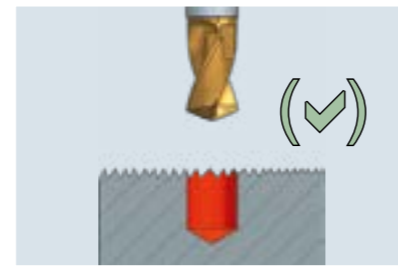

Drilling on uneven surfaces. If necessary reduce feed rate.¹⁾



Drilling on sloped surfaces.¹⁾

Only for tools < 2xd and up to 6° max. Reduce feed rate if 2° to 80%, if 5° to 70%, if 6° to 50%

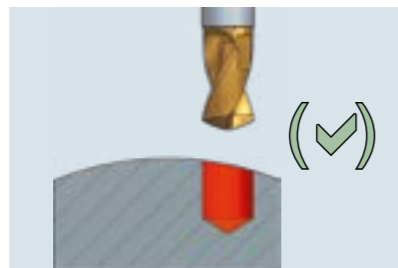

Drilling on not central or convex, concave surfaces.¹⁾

Only for tools < 2xd and up to 6° max. Reduce feed rate if 2° to 80%, if 5° to 70%, if 6° to 50%

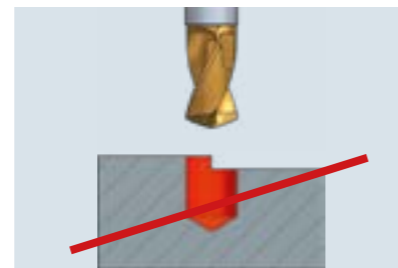

Drilling on an edge, forged or cast iron seam: Not possible.

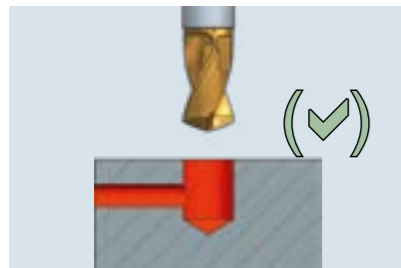

Drilling through a cross hole. Ø cross bore max 0.5xmain bore. If necessary, reduce feed rate.²⁾

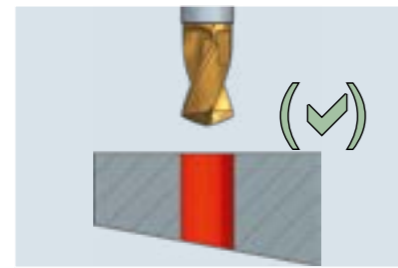

Sloped exit of the bore. Reduce feed rate to approx. 50-60%.¹⁾

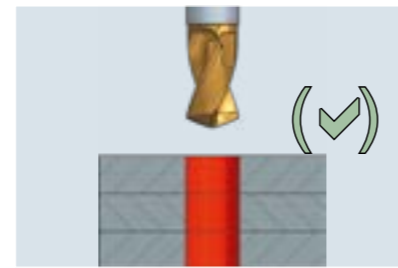

Drilling through several layers. Seamless clamping of the different workpieces is necessary.

1) Chamfer will not be clean.

2) Tool can break. Blade for deburring can get stuck in the cross hole. Drive through the bore with no rotation of the tool.

Cooling

Through tool coolant is necessary for the optimal swarf evacuation.

Coolant pressure for max. 2xd 8 bar at least. Flow rate 5 to 20 litre/min.

Use external cooling only up to max. 1xd and with reduced feed rate.

FAQ VEX

Built-up edge	Chip jam	Burr formation on the exit of the bore	Unsteady accuracy	Bad quality of the surface	Chatter	Wearing of major cutting edge	Wearing of cross cutting edge	Wearing of major chamfer	Wearing of clearance surface	Breakout of cutting edge	Breakout of the top of the drill bit	
												Raise cutting speed
												Reduce cutting speed
												Raise feed rate
												Reduce feed rate
												Raise coolant pressure
												Check radial run-out
												Check stability of spindle and setting
												Exchange worn drill bit
												Improve drilling cycle
												Coating

Assembly / Dismantling

Assembly

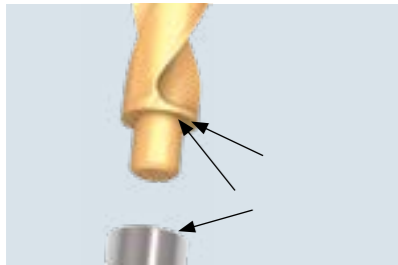

Clean the surfaces between the VEX drill bit and the tool body.



Screw tightly the drill bit with a flat wrench to the tool body.
For torque / torque spanner see page 233.

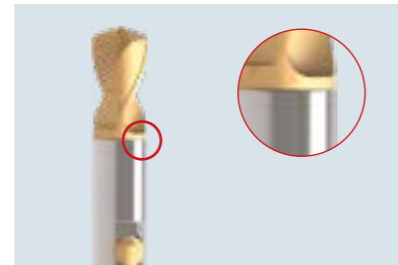

There should be a seamless transition between drill bit and tool body after the tightening of the drill bit (no light gap between tool body and drill bit).

Reasons for a Light Gap and How to Correct

Reason	Solution
Dirt between drill bit and tool body	Dismantle and clean.
Drill bit is not tightened enough.	Tighten drill bit once more.
Adaption areas are damaged	Exchange drill bit and/or tool body.

Dismantling

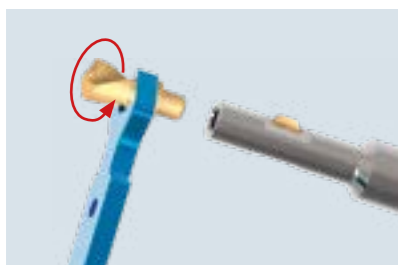

Unfasten the drill bit with a flat wrench in counter-clockwise direction from the tool body.

Re-grinding

All VEX drill bits can be re-ground once. We recommend the following parameter:

Nose angle: 140°
Clearance angle: 8°
Point thinning: regrind a little

Please note that the re-grinding will change the original VEX point geometry and therefore we recommend that only 1-2 mm maximum should be removed. The original grind form can only be reproduced by HEULE.

For the re-grinding of the helical drill bit we have created the following re-grinding device:

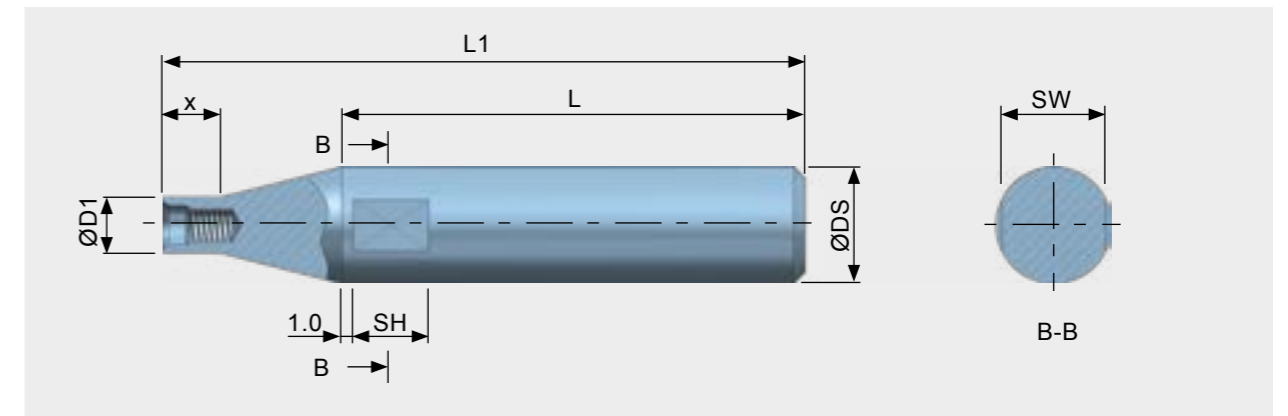

									Re-grinding device
Series	Thread	ØD1	ØDS	x	L	L1	SW	SH	Part No.
B	M3*0.35	4.8	10.0	5.0	40.0	55.4	9.0	6.5	GH-V-V-0052
C	M4*0.5	5.8	10.0	5.0	40.0	55.8	9.0	6.5	GH-V-V-0053
D	M5*0.5	6.8	10.0	5.0	40.0	56.0	9.0	6.5	GH-V-V-0054
E	M6*0.75	8.3	16.0	8.0	50.0	70.6	14.0	7.0	GH-V-V-0055
F	M8*0.75	10.3	16.0	8.0	50.0	70.3	14.0	7.0	GH-V-V-0056

Spare Parts

The spare parts that are not listed in this chapter can be found on the product selection pages of the specific product.

Tool Body

Bore depth 5.0 - 11.5			Tool body for bore depth 1 x d	
Bore range Ød	Bore depth T	Series	with Internal cooling	without int. cooling
			Part No.	Part No.
5.00-5.49	5.5	B	GH-Q-G-4000	---
5.50-5.99	6.0	B	GH-Q-G-4001	---
6.00-6.49	6.5	C	GH-Q-G-4002	GH-Q-G-4022
6.50-6.99	7.0	C	GH-Q-G-4003	GH-Q-G-4023
7.00-7.49	7.5	D	GH-Q-G-4004	GH-Q-G-4024
7.50-7.99	8.0	D	GH-Q-G-4005	GH-Q-G-4025
8.00-8.49	8.5	D	GH-Q-G-4006	GH-Q-G-4026
8.50-8.99	9.0	E	GH-Q-G-4007	GH-Q-G-4027
9.00-9.49	9.5	E	GH-Q-G-4008	GH-Q-G-4028
9.50-9.99	10.0	E	GH-Q-G-4009	GH-Q-G-4029
10.00-10.49	10.5	E	GH-Q-G-4010	GH-Q-G-4030
10.50-10.99	11.0	F	GH-Q-G-4011	GH-Q-G-4031
11.00-11.49	11.5	F	GH-Q-G-4012	GH-Q-G-4032

Bore depth 11.0 - 23.0			Tool body for bore depth 2 x d	
Bore range Ød	Bore depth T	Series	with Internal cooling	without int. cooling
			Part No.	Part No.
5.00-5.49	11.0	B	GH-Q-G-4050	---
5.50-5.99	12.0	B	GH-Q-G-4051	---
6.00-6.49	13.0	C	GH-Q-G-4052	GH-Q-G-4072
6.50-6.99	14.0	C	GH-Q-G-4053	GH-Q-G-4073
7.00-7.49	15.0	D	GH-Q-G-4054	GH-Q-G-4074
7.50-7.99	16.0	D	GH-Q-G-4055	GH-Q-G-4075
8.00-8.49	17.0	D	GH-Q-G-4056	GH-Q-G-4076
8.50-8.99	18.0	E	GH-Q-G-4057	GH-Q-G-4077
9.00-9.49	19.0	E	GH-Q-G-4058	GH-Q-G-4078
9.50-9.99	20.0	E	GH-Q-G-4059	GH-Q-G-4079
10.00-10.49	21.0	E	GH-Q-G-4060	GH-Q-G-4080
10.50-10.99	22.0	F	GH-Q-G-4061	GH-Q-G-4081
11.00-11.49	23.0	F	GH-Q-G-4062	GH-Q-G-4082

Flat Wrench / Torque Spanner

Bore range Ød	Bore depth T	Series	Wrench-size SW	Tightening torque Ncm	Flat wrench	Torque key insert	Torque Screw driver
					Part No.	Part No.	Part No.
5.00-5.49	11.0	B	4.0	170	GH-H-S-2301	GH-H-S-2331	GH-H-S-2401
5.50-5.99	12.0	B	4.0	170	GH-H-S-2301	GH-H-S-2331	GH-H-S-2401
6.00-6.49	13.0	C	5.0	250	GH-H-S-2301	GH-H-S-2332	GH-H-S-2401
6.50-6.99	14.0	C	5.0	250	GH-H-S-2301	GH-H-S-2332	GH-H-S-2401
7.00-7.49	15.0	D	6.0	400	GH-H-S-2302	GH-H-S-2333	GH-H-S-2402
7.50-7.99	16.0	D	6.0	400	GH-H-S-2302	GH-H-S-2333	GH-H-S-2402
8.00-8.49	17.0	D	7.0	400	GH-H-S-2302	GH-H-S-2334	GH-H-S-2402
8.50-8.99	18.0	E	7.0	600	GH-H-S-2302	GH-H-S-2334	GH-H-S-2402
9.00-9.49	19.0	E	8.0	600	GH-H-S-2303	GH-H-S-2335	GH-H-S-2402
9.50-9.99	20.0	E	8.0	600	GH-H-S-2303	GH-H-S-2335	GH-H-S-2402
10.00-10.49	21.0	E	9.0	600	GH-H-S-2303	GH-H-S-2336	GH-H-S-2402
10.50-10.99	22.0	F	9.0	600	GH-H-S-2303	GH-H-S-2336	GH-H-S-2402
11.00-11.49	23.0	F	9.0	600	GH-H-S-2303	GH-H-S-2336	GH-H-S-2402

SNAP Chamfering Blades

Function Principle

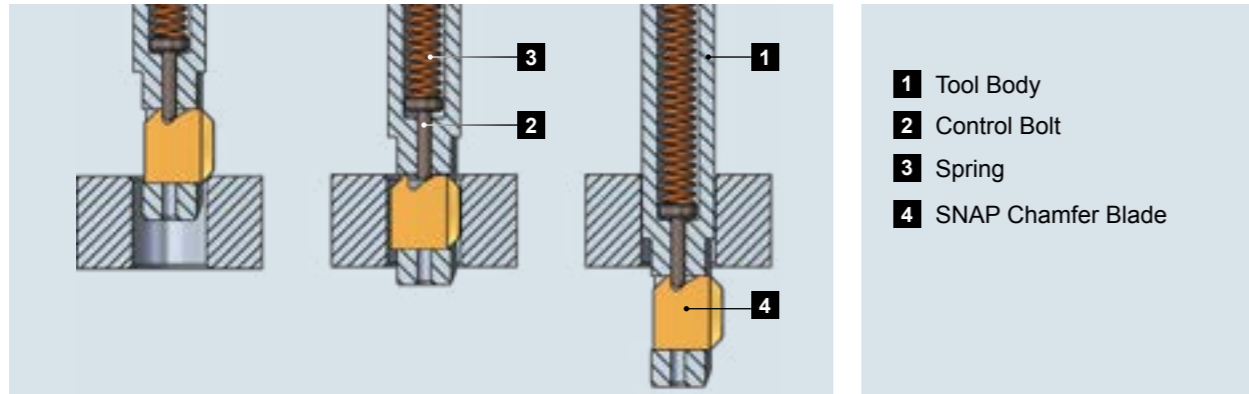

The SNAP deburring blade remains moveable in the tool body via a control bolt held under spring pressure. A specially ground forward and backward or backward cutting only blade produces the required chamfer while the tool enters the bore. Once the chamfer size is attained, the deburring blade continuously retracts into the tool body. On a specially designed gliding radii, the blade passes through the hole without damaging it. The deburring

blade has a special recess which the control bolt engages and after exiting the hole brings the blade back into its starting position. A smooth deburring or chamfering operation forwards and backwards is the result of this machining operation. Chamfer size and chamfer angle are predetermined geometrically at the blade and can only be changed by the use of another blade of an adapted design.

Blade Change

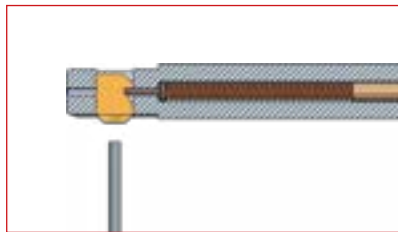

SNAP-Tool with assembled blade

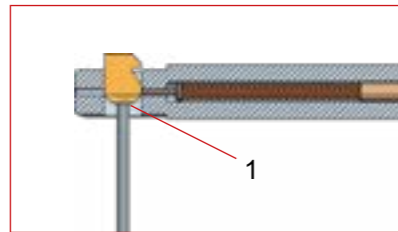

The SNAP blade can be pushed through the tool with an edgeless object. Put the aid on at the blade head (1).

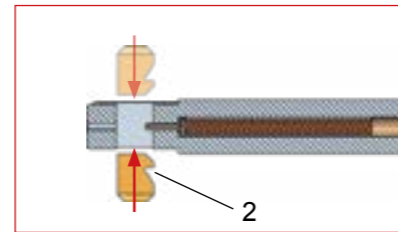

The deburring blade is pushed with its back first into the blade window of the tool until it engages. Please make sure that it is aligned with the recess (2) in the direction of the tool shank.

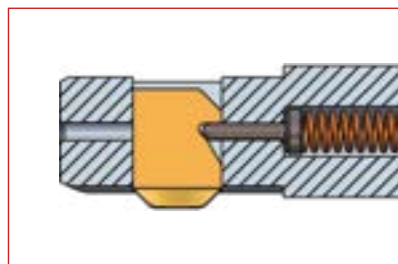

The control bolt has "snapped" into the blade recess. The tool is now ready for operation.

Blade Geometries

Blades with GS Geometry

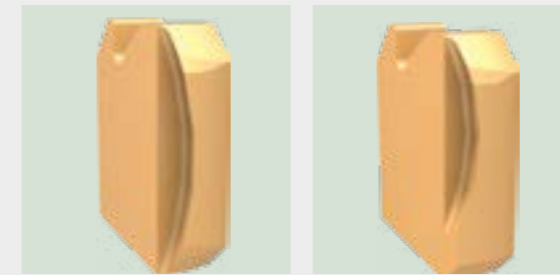

forward and backward cutting

backward cutting only

The blade with the **GS geometry is the standard blade**. As a universal blade it is suitable for most deburring and easy chamfering operations. This blade can also be used in applications where there is slight unevenness on the surface of the component.

Front and back chamfering is achieved by linear feed forward and backward. For back cutting only, a front and back cutting blade can be used also by traversing through the hole in rapid feed without causing damage to either the front edge of the hole or to the tool.

Only when no deburring or chamfering is required or accepted on the front edge of the hole, it is necessary to use the back cutting only blades.

You will find the GS blades on page 236.

NOTE:

In case of increased requirements due to particularly hard materials or materials with large burr formation, please contact your HEULE sales person. After examination we are also able to offer application-specific blade geometries.

Cutting Data¹

Material	Condition	Tensile strength (N/mm ²)	Hardness HB	SNAP 5 GS Geometry	
				Cutting speed (m/min)	Feed (mm/rev)
Unalloyed steel		<500	<150	40-70	0.1-0.3
Cast steel		500 - 850	150 - 250	40-70	0.1-0.3
Grey cast iron		<500	<150	50-90	0.1-0.3
Ductile cast iron		300 - 800	90 - 240	40-70	0.1-0.3
Low alloy steel	annealed	<850	<250	40-70	0.1-0.3
	tempered	850 - 1000	250 - 300	30-50	0.1-0.2
	tempered	>1000 - 1200	>300 - 350	30-50	0.1-0.2
High alloy steel	annealed	<850	<250	20-50	0.1-0.2
	tempered	850 - 1100	250 - 320	15-30	0.1-0.15
Stainless steel	ferritic	450 - 650	130 - 190	15-30	0.05-0.15
	austenitic	650 - 900	190 - 270	10-20	0.05-0.15
	martensitic	500 - 700	150 - 200	15-30	0.02-0.15
Special alloy (Inconel, titanium)		<1200	<350	10-20	0.02-0.1
Wrought or cast aluminium alloys				70-120	0.1-0.3
Copper alloy	Brass			60-90	0.05-0.15
	Bronze short-chipping			30-50	0.05-0.15
	Bronze long-chipping			20-30	0.05-0.15

¹⁾ All listed cutting data are standard values only! They can differ considerably according to the specific application (clamping of workpiece, machine or nature of workpiece). We recommend to apply cutting speeds that are at the lower end of the range for uneven bore edges.

SNAP5 Blades GS Geometry 90° for VEX Combi Tools

Chamfer Ø ¹⁾	Part No. forward and backward cutting		backward cutting only	
	Coating A	Coating D	Coating A	Coating D
5.5	GH-Q-M-30204*	GH-Q-M-30404	GH-Q-M-31204	GH-Q-M-31404
6.0	GH-Q-M-30205*	GH-Q-M-30405	GH-Q-M-31205	GH-Q-M-31405
6.5	GH-Q-M-30206*	GH-Q-M-30406	GH-Q-M-31206	GH-Q-M-31406
7.0	GH-Q-M-30207*	GH-Q-M-30407	GH-Q-M-31207	GH-Q-M-31407
7.5	GH-Q-M-30208*	GH-Q-M-30408	GH-Q-M-31208	GH-Q-M-31408
8.0	GH-Q-M-30209*	GH-Q-M-30409	GH-Q-M-31209	GH-Q-M-31409
8.5	GH-Q-M-30210*	GH-Q-M-30410	GH-Q-M-31210	GH-Q-M-31410
9.0	GH-Q-M-30211*	GH-Q-M-30411	GH-Q-M-31211	GH-Q-M-31411
9.5	GH-Q-M-30212*	GH-Q-M-30412	GH-Q-M-31212	GH-Q-M-31412
10.0	GH-Q-M-30213*	GH-Q-M-30413	GH-Q-M-31213	GH-Q-M-31413
10.5	GH-Q-M-30214*	GH-Q-M-30414	GH-Q-M-31214	GH-Q-M-31414
11.0	GH-Q-M-30215*	GH-Q-M-30415	GH-Q-M-31215	GH-Q-M-31415
11.5	GH-Q-M-30216*	GH-Q-M-30416	GH-Q-M-31216	GH-Q-M-31416
12.0	GH-Q-M-30217*	GH-Q-M-30417	GH-Q-M-31217	GH-Q-M-31417

* Standard items / Please enquire about stock or delivery times for all non-standard items.

¹⁾ The indicated dimension is the theoretically possible maximum.

Explanations to coatings

A: Coating for steel, titanium, Inconel

D: Coating for aluminium alloys only

Adjusting the Chamfer Size

SNAP blades with GS geometry

In general, the chamfer size is defined by the selected blade (blade length). Each blade produces a defined chamfer size.

The theoretically possible chamfer size maximum can be taken from the column "chamfer-Ø max. D" in the blade tables.

Setting the Blade Force

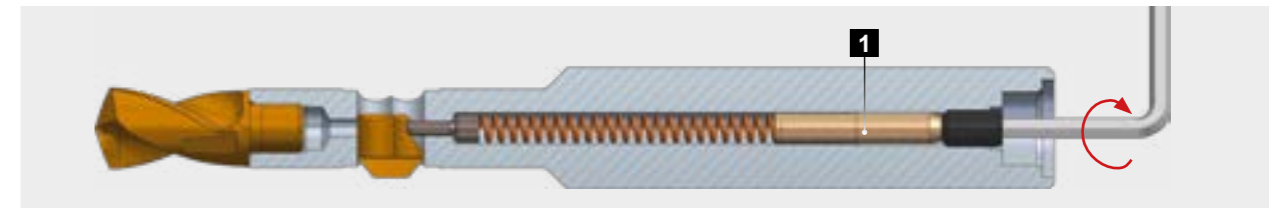

The blade force can be adjusted by the set screw (1) in the rear of the shank. The blade force has to be sufficient to extend the blade to fully after passing the back end of the bore. This ensures that the blade can work with the necessary cutting performance. The tougher the material, the tougher the spring should be set. The blade force, however, does not influence the chamfer size. Working with the correct blade pressure increases the blade life and improves the chamfer quality. An extremely

tough material requires a high spring force. For this purpose, the springs can be exchanged (SNAP5: GH-H-F-0041, SNAP8 und SNAP12: GH-H-F-0011).

Turning the set screw clockwise increases the blade force (tough steel, Inconel, titanium). Turning the set screw counter-clockwise reduces the blade force (aluminium).

Adjustment Details Blade Force

Tool	Thread size	Screw-in depth max.	Revolutions (approx.)
SNAP5	M3	6.0 mm	12 x



X-BORES
Online Information



Case Studies

www.heule.com/en/case-studies/?t=118



Contact Sales Represent.

www.heule.com/en/contact-sales-representatives



Request for Quote Form

www.heule.com/en/Anfrageformular

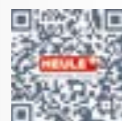

X BORES

Deburring of Cross Bores.

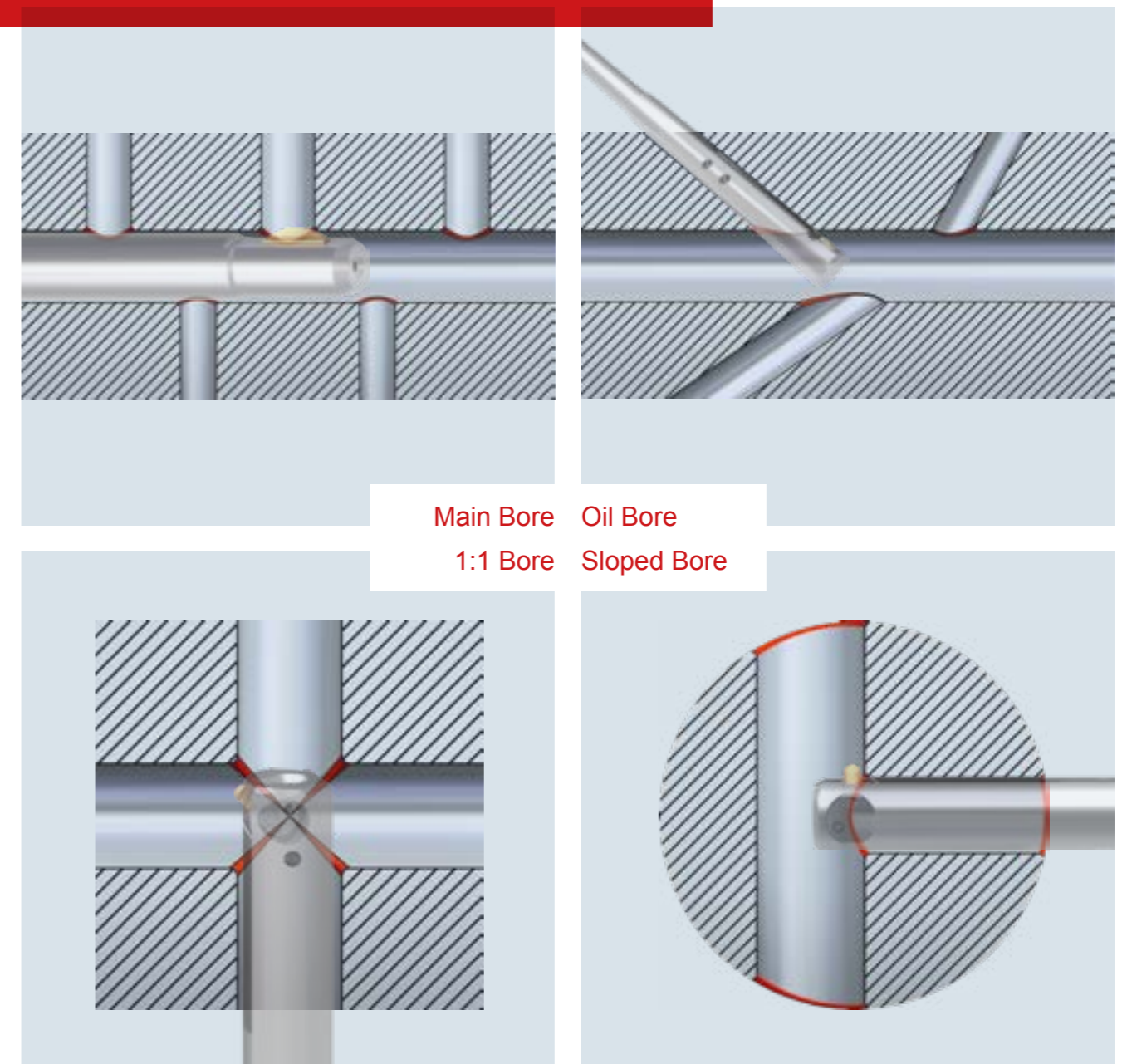

Main Bore Oil Bore
1:1 Bore Sloped Bore

With X-BORES HEULE takes up the challenge to provide solutions for the automated deburring of cross bores. Based on 4 different function principals we develop individual and optimized customer solutions. All systems are chip making tools that work with defined cutting edges to ensure a high process capability.

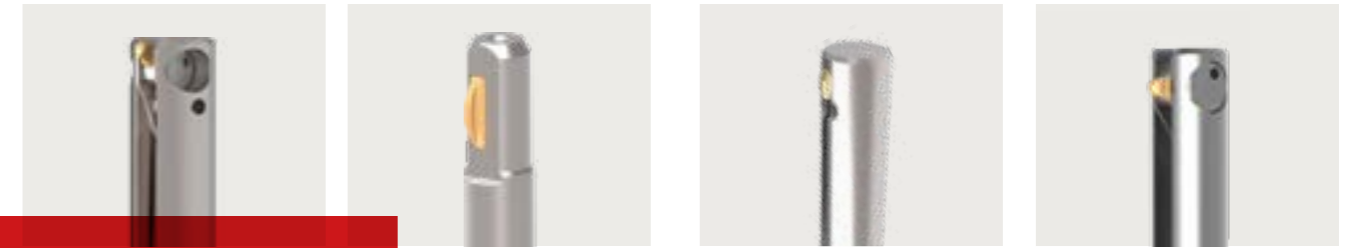

With X-BORES HEULE takes up the challenge.

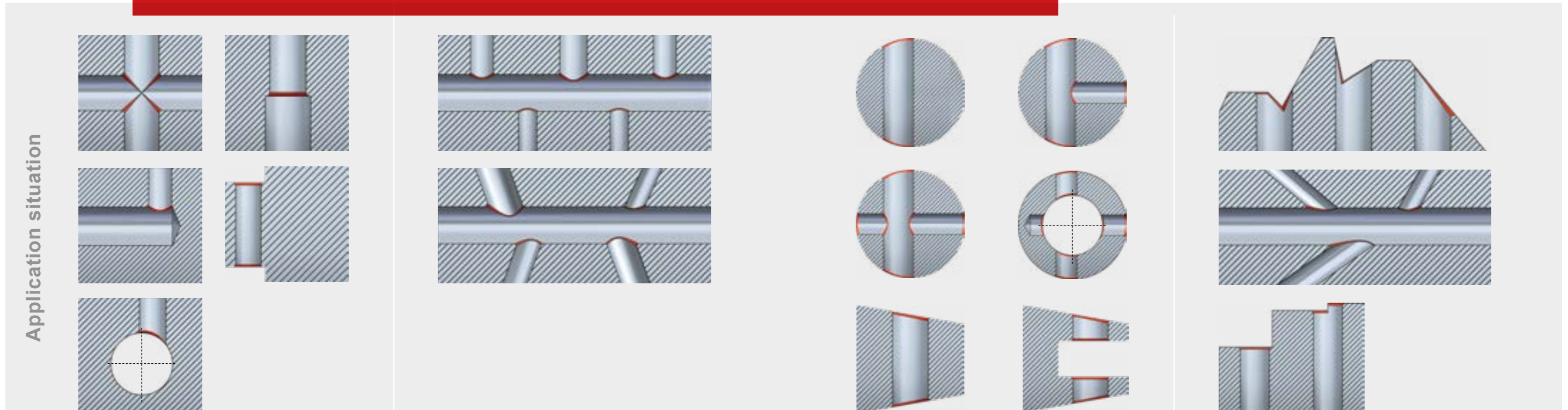

Application situation

Challenge

Bores with an identical or almost identical diameter crossing each other, bores which merge into one another, crossing bores with center axis offset and interfering edges that shield the surface to be deburred indirectly.

The main bore is a central bore where several cross bores lead in. The cross bores usually have various diameters and lead into the main bore in different angles.

Sloped, uneven or even surfaces and crossing bores with regard to the penetration angle.

Beside the classic oil bore, this category covers very complex intersecting bores one usually finds in tothing or steps and intersecting bores with a very flat penetration angle.

Solution approach

The 1:1 Ratio Bore Tool

With its COFA-X-System combined with today's machine capabilities HEULE possesses a new solution. This method enables the machining of contours that were inconceivable some years ago.

The Main Bore Tool

The Main Bore Tool SNAP-X is used for the deburring of cross bores leaving sharp edges. It penetrates through the main bore and deburrs the cross bores. In one single pass, several cross bores are machined right at the burr base.

The Universal Efficiency Champion

COFA removes burrs on the front and back of a drilled through-hole on even and uneven surfaces in a single cycle. It radially removes the burrs without requiring the workpiece to be turned or the spindle to be stopped. This is why it is suitable for the deburring of cross bores.

The Cross Bore Tool

The CBD (Cross Bore Deburring Tool) has been developed to deburr oil bores. The tool penetrates the cross bore and deburrs the bore intersection in an absolute process-safe manner.

X-BORES



COFA-X
Online Information



Product

www.heule.com/en/applications/cross-bores/1to1ratio-bore



Case Studies

www.heule.com/en/case-studies/?t=117



Contact Sales Represent.

www.heule.com/en/contact-sales-representatives



Request for Quote Form

www.heule.com/en/Anfrageformular



COFA-X

The mechanical deburring tool for cross bores with a diameter ratio of 1:1.

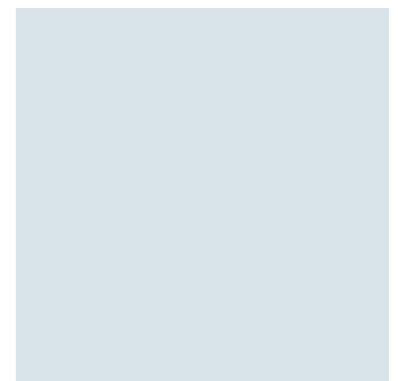
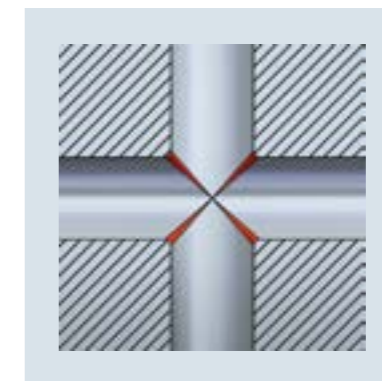
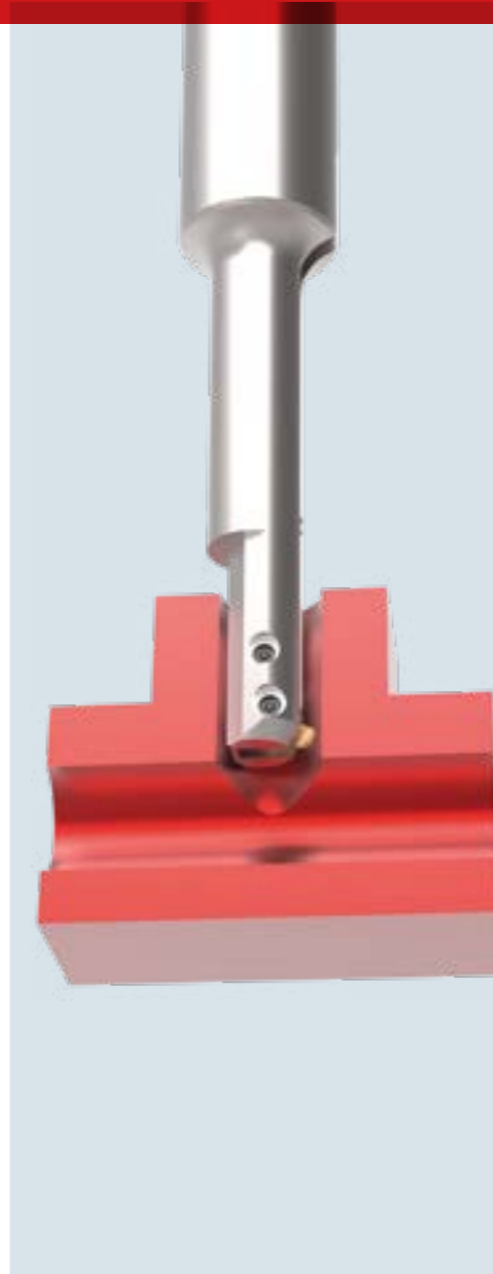

Deburring of Intersecting Bores with up to almost Identical Diameter

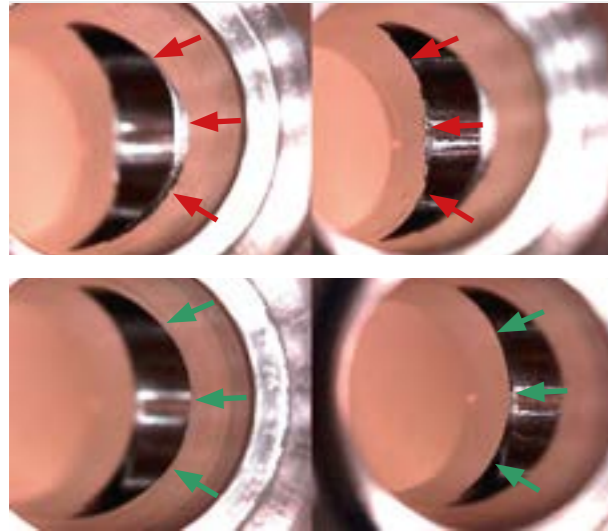

Image 1: The bore edge is clean and completely free of burrs.
Top: Before deburring Bottom: After deburring.

Cross bores with almost identical diameters show a very steep unevenness. This condition made it impossible to deburr such cross bores mechanically so far. The shape of the intersection did not allow a complete deburring of the bore.

By solving this challenge HEULE proves once again their competence as a solution provider. We are making use of today's machine capabilities and combine them with a new tool, the COFA-X system.

The defined cutting process using a carbide blade is responsible for a complete edge break. In other words the edge is burr-free.

Function Principle and Possible Applications

Tool function

COFA-X is the first and only tooling system that removes the burrs consistently from interior uneven bore edges in applications with large intersections. It works reliably when NC operated and it is highly efficient and process capable. This simple and mechanically controlled deburring tool reduces your process costs and increases the process capability of the deburring operation massively.

The COFA-X application range starts with bore diameters of $\varnothing 4.0$ mm and larger. In any case, all COFA-X-tools must be designed individually according to the customers' needs. This explains why a detailed application description is compulsory. One tool machines one diameter. However, all COFA-X tools have in common that they do not cause any secondary burrs.

In order to assure a reliable NC operation the machine requirements have to be respected. The tool has to be inserted into the bore with an offset (Image 1).

Blade function

The tools possess special geometries that are designed either for front or back cutting only. Accordingly, the blades are preloaded by a spring when assembled. Compared to the COFA standard tool the blade position is different for this reason.

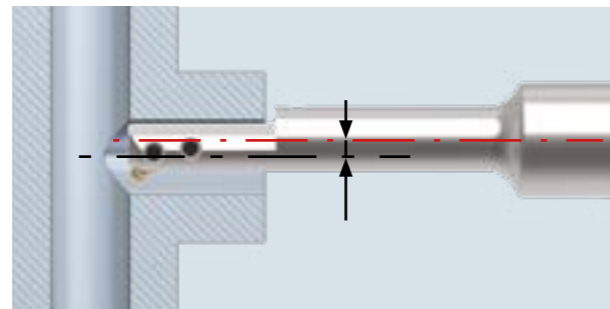

Image 2: The deburring tool accesses the T piece via the cross bore.

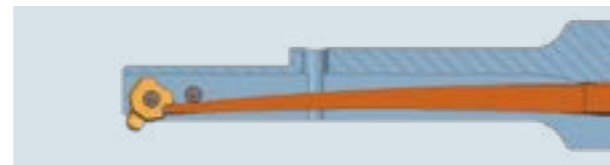
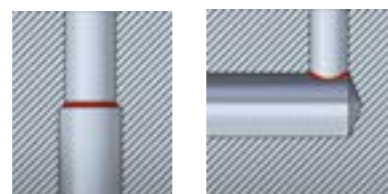
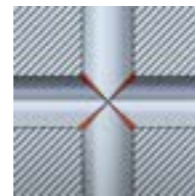

Image 3: The preloaded spring and the shaft with a recess enable the tool to deburr bores with a high degree of unevenness.

Scope of application

- Intersecting bores up to a main bore - cross bore ratio of 1:1.
- Crossing bores with center axis offset.
- Bores with interfering edges that shield the surface (bore edge) to be deburred indirectly.



Tool Concept

In comparison with the COFA standard system, COFA-X possesses a pre-loaded blade (see image 3 on page 244) and the tip of the tool body shows a recess. This recess is necessary in order to enter the bore with an offset so that the blade does not suffer.

The tool itself is characterized by its simple setup. The exchangeable spring is held safely in the tool body by two split pins. It controls the movement of the blade and resets it to the initial position after processing.

The multiple use of blade and spring within a serie is given. Only the tool body has to be selected according to the bore diameter.

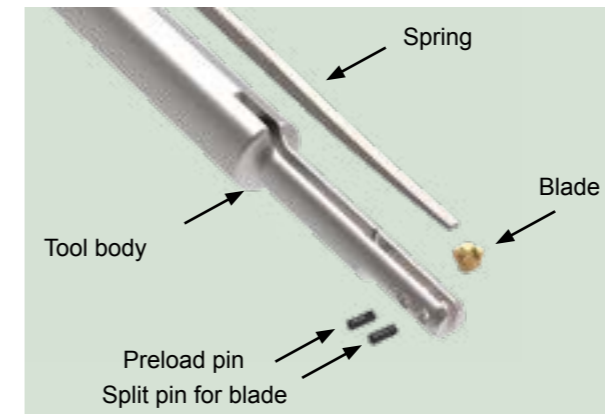
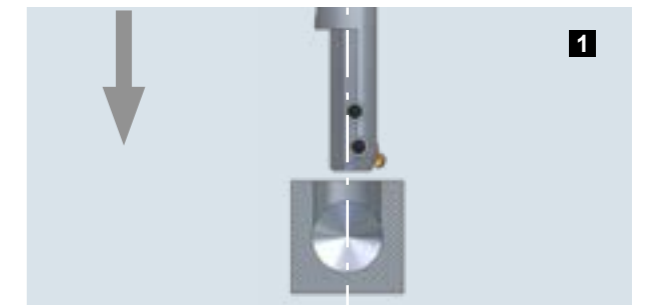

Image 4: To change the blade only remove the front split pin and swivel it out of the spring.

Information / data required by HEULE to examine the feasibility of your application.

- Main bore- \varnothing including tolerance
- Cross bore- \varnothing including tolerance
- Bore depth
- Material
- Penetration angle
- Offset
- Production volume per year
- Cycle time
- Machine (NC / others)
- Solution / process today
- Particular requirements
- STEP drawing

Sequence of Operation / Programming



Approach with spindle stopped, orientated and offset 0

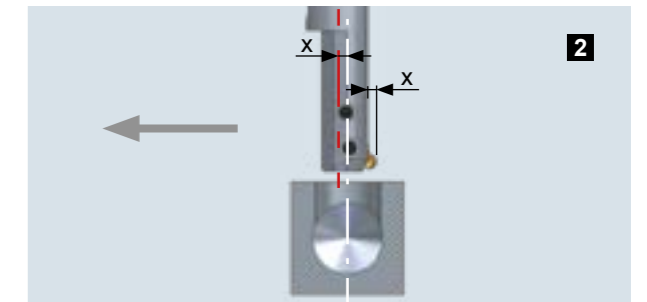

Approach offset dimension x. Value depends from the distance of the blade exceeding the tool body.

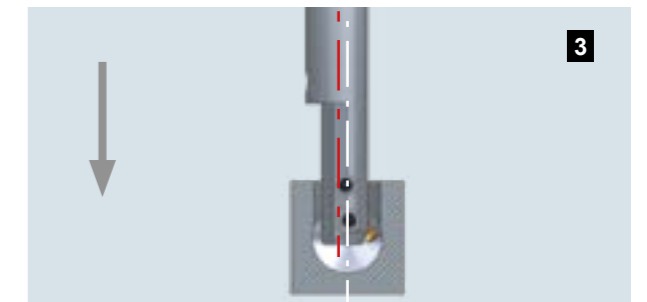

Enter the bore down to the bore edge to be deburred.

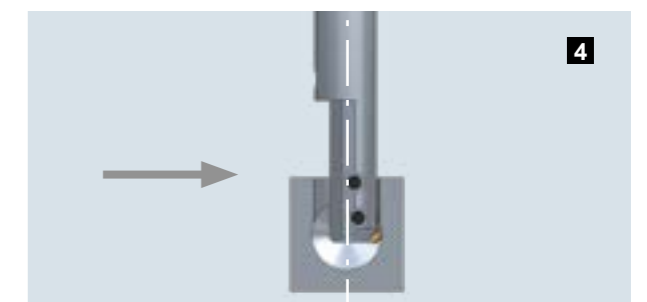

Move back to offset dimension 0.



Spindle ON. Execute deburring in working feed backwards.



SNAP-X Online Information



Product

www.heule.com/en/applications/cross-bores/main-bore



Case Studies

www.heule.com/en/case-studies/



Contact Sales Represent.

www.heule.com/en/contact-sales-representatives



Request for Quote Form

www.heule.com/en/Anfrageformular



SNAP-X

Deburring tool for main bores.

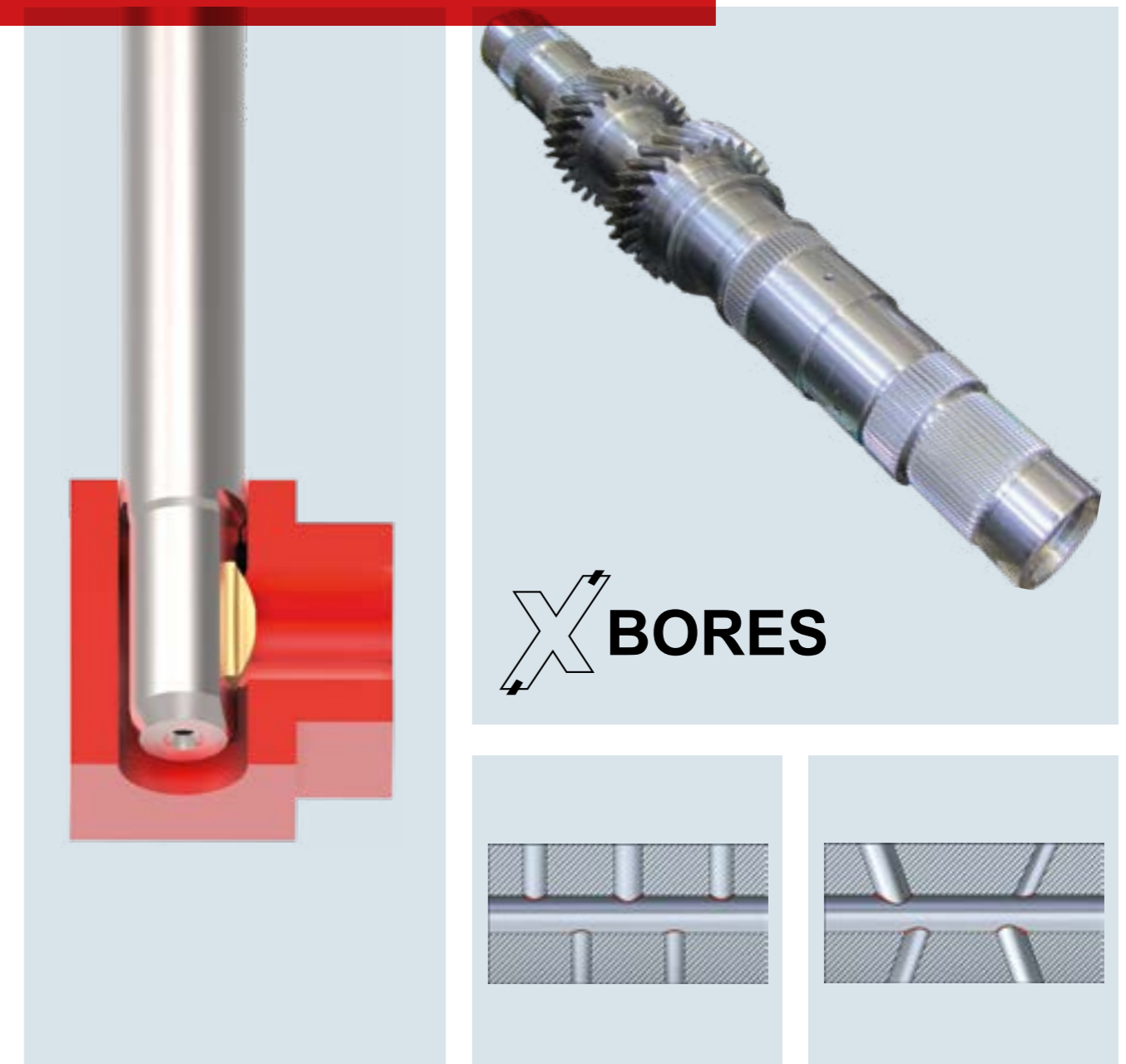

XBORES

With SNAP-X HEULE advances into uncharted technical territory that has been out of reach so far. This special tool penetrates by the main bore and deburrs the entering cross bores. In close cooperation with the customer, our R&D team examines the feasibility and develops a tailor-cut tool for the specific application.

The mainbore solution is based on the proven SNAP system. SNAP-X has been conceived for NC operation and for large production runs. The exchange of the blades is extremely simple and can be carried out by hand in no time.



Image 1: Process capable for large production runs - as an example, drive shafts for a manual gearbox machined on a transferline by SNAP-X.

Function Principle and Possible Applications

Setup and function principle

The radially supported and spring-loaded SNAP-X blade penetrates the cross bore in work feed and deburrs it, no matter what the diameter of the cross bore is. The especially ground blade fulfills its work while moving forward as well as backward where the direction of the spindle rotation is reversed.

When leaving the cross bore, the guiding edge of the SNAP-X blade moves it back into the tool body in a controlled manner. A especially designed gliding section prevents the main bore from being hurt.

the blade edge and the blade length. Given by the constellation of the two circle segments (crossbore and blade) the blade is able to work its way out continuously and at the same time, it carries out the deburring in a skinning way of cutting.

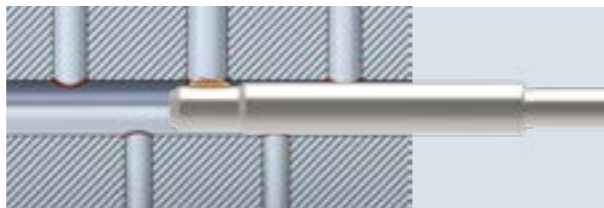

Image 2: Several cross bores are deburred in one single pass through the main bore.

Process description

The tool blade is positioned in rapid feed in front of the cross bore to be deburred. In work feed forward and with work speed the edges of the intersection are being machined. With clockwise rotation all intersecting bores are deburred now in one single pass. In order to assure the best possible deburr result, the spindle rotation is switched to anti-clockwise rotation and all crossbores are machined a second time on the tools way out of the mainbore.

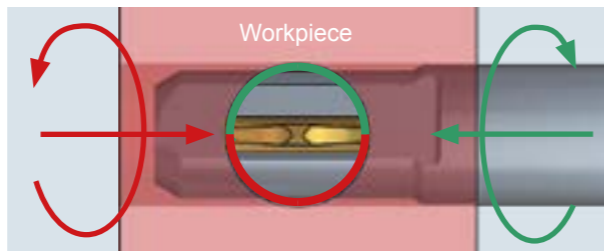

Image 3: The blade is conceived for forward and backward cutting. Before moving back out, the direction of the spindle rotation is changed to machine the bores a second time with the backward cutting side assuring the required process capability.

The tool body shows a recess in the most important cutting direction (feed direction). This prevents the burrs from being pushed down or bent into the cross bore in advance.

In general, extra long tools are usually assembled (multi-piece construction) and require an adequate guidance in the mainbore direction as well as a generously dimensioned chamfer. It is strongly recommended not to activate the tool/spindle without guidance.

Blade function

The blade is built with a clockwise and an anti-clockwise working cutting edge. Its form is convex and adapted to the crossbore. It enters the crossbore to the extent limited by the geometry/radius of

Scope of applications

- Mainbores
- Intersecting bores in different diameters up to a ratio of close to 1:1
- Several crossbores lead into a mainbore in different angles and diameters.



The tool is characterised by its simple design. It consists of very few components with one screw only. The blade is kept movable in the tool body via a control bolt held under spring pressure. The blade has a special ramp-shaped recess where the control bolt engages in. While machining, the bolt glides up the ramp and increases the pressure on the blade. This brings the blade back to the starting position when exiting the bore again.

The blade can be exchanged by hand within no time and without any tools.

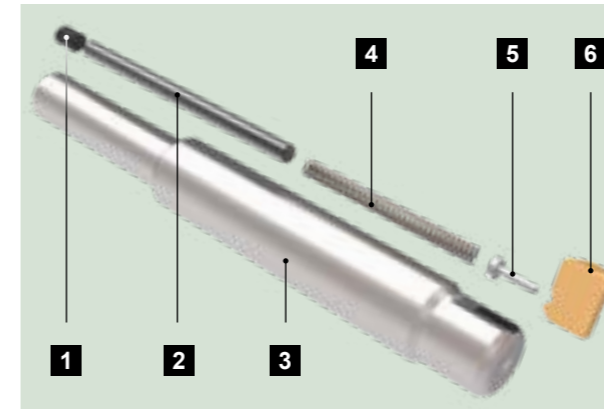
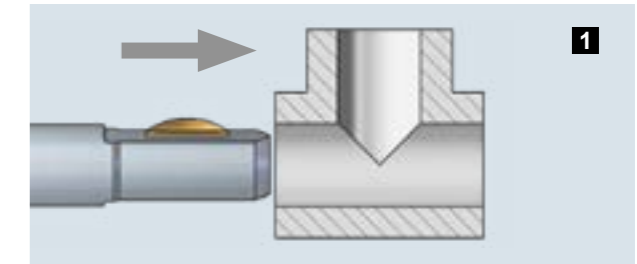
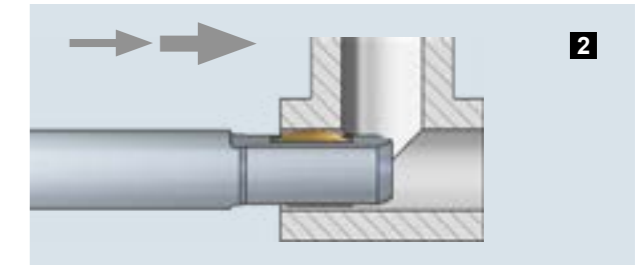

Image 4: 1-Set screw, 2-Distance pin, 3-Tool body, 4-Spring, 5-Control bolt, 6-Blade



First, in rapid traverse and with the spindle stopped, move the tool head 0.5 mm ahead of the main bore entrance.



In working feed, insert the tool/blade into the main bore. Then, continue in rapid traverse to the first cross bore. Stop immediately ahead of the bore.

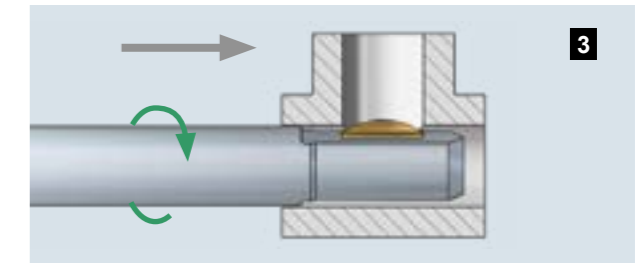

Machine the cross bore in working feed and the spindle rotating clockwise. Once finished, move in rapid traverse and the spindle still rotating to the next cross bore.

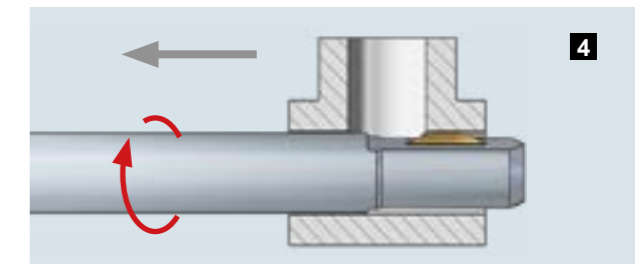

After the last cross bore, change the rotation direction of the spindle to anti-clockwise and repeat all operation procedures on the way back.

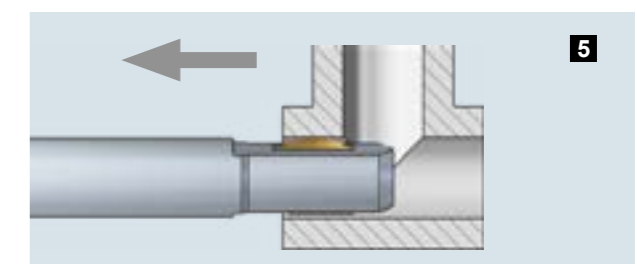

Once finished machining the last cross bore, stop the spindle rotation and move out of the main bore in rapid traverse.

Information / data required by HEULE for the feasibility study of your application:

- Main bore-Ø including tolerance
- Cross bore-Ø including tolerance
- Position of the cross bore in relation to the main bore (drawing or model)
- Working length
- Material
- Shank-Ø (possibly with special shank length)
- Interfering edges (Drawing of machine situation and clamping situation)
- Required deburring quality (i.e.residual burr)
- Production volume per year
- Cycle time deburring
- Machine (NC / others / cooling)
- Particular requirements
- STEP drawing



CBD
Online Information



Product

www.heule.com/en/applications/cross-bores/oil-bores



Case Studies

www.heule.com/en/case-studies/



Contact Sales Represent.

www.heule.com/en/contact-sales-representatives



Request for Quote Form

www.heule.com/en/Anfrageformular



CBD

The unique deburring tool for oil bores from Ø4.0 bis Ø10.0 mm.

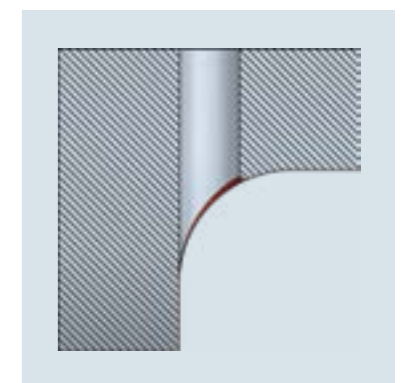
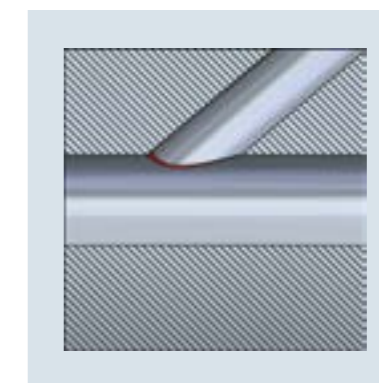
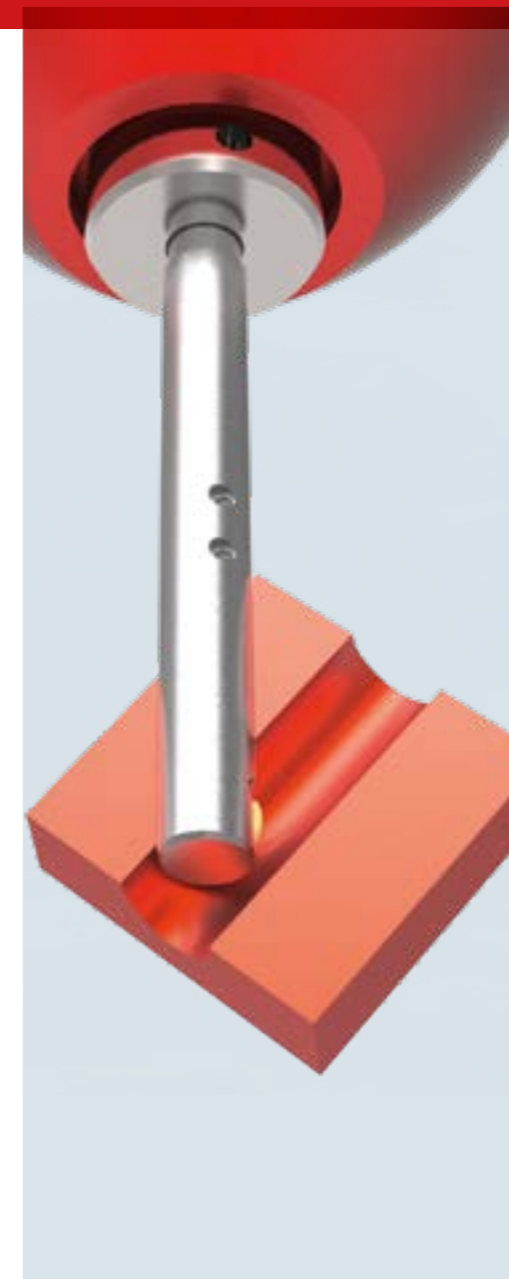

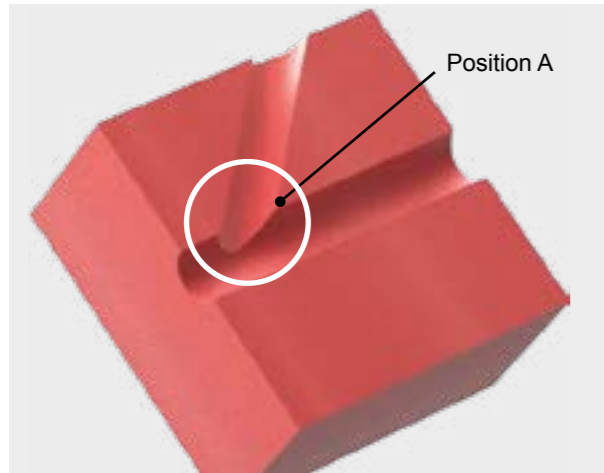

Image: Intersecting bores with minimal ratio of the main to the cross bore and flat penetration angle

The existing deburring tools are limited when it comes to deburr intersecting bores with a minimal ratio of the main to the cross bore or with a very flat penetration angle of the cross bore. They do not achieve a fully satisfying deburr result because of the shape of the intersection. In particular, the present systems regularly fail to remove the burr at position A thoroughly.

HEULE set the goal to close this gap and has developed the CBD Cross Bore Deburring tool. A new unique system that works 100% mechanically and that deburrs a 1:1 intersection by a chip making machining process. The defined cutting process ensures a complete edge break which results in a burr free bore edge.

Function Principle of the CBD tool

Usually the rotation axis defines the working direction of a deburring tool whereas the longitudinal axis serves as feed direction (COFA principle). For the new concept (CBD principle), HEULE changed this working method. Now, the longitudinal axis serves as the working direction and the rotation axis works as an axial feed direction. The machining process is carried out through the cross bore into the main bore.

In this case, the bore intersection will be cut segment by segment by the blade. This offers the advantage that the blade can reach every point of the intersecting contour and that the burr will be removed including its root.

Blade function

When entering the cross bore the blade slides over the retract surface and moves into the tool body preloading the spring at the same time. When moving through the bore, the slide radius prevents the bore surface from being damaged. The tool overtravels the bore edge to be deburred and the blade is pushed back by the preloaded spring into its initial position.

During the reverse stroke the cutting edge of the blade removes a segment of the bore edge with the burr. The control surface is responsible that the blade slides back into the tool body. The tool body will then rotate by a defined angle (around its rotation axis) and the process will be repeated. This procedure continues until the complete circumference of the bore is free of burrs.

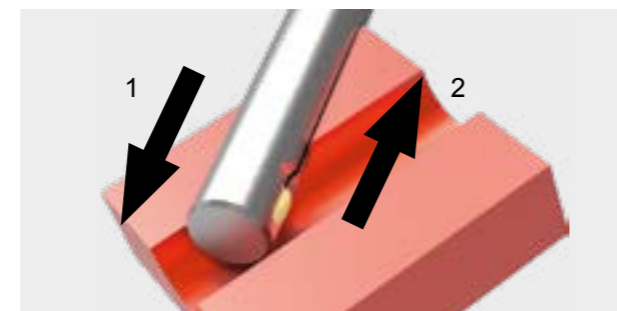
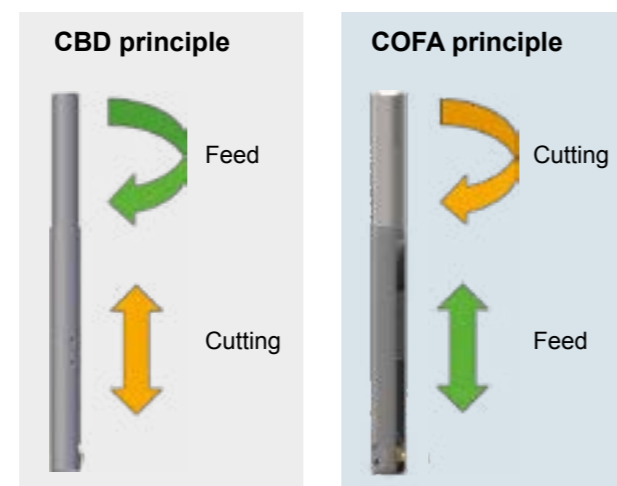
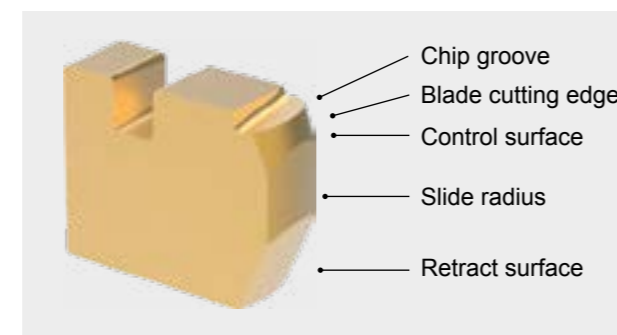

Image 1: - Stroke movement over the bore edge with the burr into the main bore 2 - Reverse stroke = cutting movement



Control unit

In order to achieve the necessary working speed and also to spare the machine tool itself, HEULE has designed a control unit. It generates the oscillating cutting movement as well as the rotating feed movement.

The stroke length and the feed are defined by the application. This means that each control unit is configured individually with standardized components according to the parameters of the application. An example: At a spindle speed of 600 rev/min the control unit generates 1200 strokes/min, respectively 20 strokes/sec and a feed of 10 rev/min. The NC anti rotation device permits an automatic tool change. It has to be adapted to the machine tool herefor.

Tool

The tool is distinguished by its simple set-up. The spring is held loss protected in the tool body by two split pins. The spring controls the blade and pushes it back into the initial position while working.

The blade and the spring are applicable for different diameters. Only the tool body has to be chosen according to the bore diameter. For changing the blade the front split pin has to be removed to be able to swing out the spring.

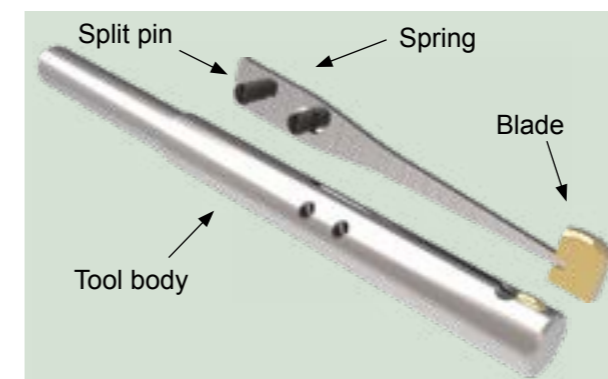

Image 2: - Replacing the carbide blade can be done manually and within no time.

Required application data by HEULE:

- Main bore-Ø including tolerance
- Cross bore-Ø including tolerance
- Bore depth
- Material
- Penetration angle
- Offset
- Distance anti rotation device
- Distance gauge line
- Production volume per year
- Cycle time
- Machine (NC / other)
- Applied solution today
- Particular requirements
- STEP drawing data



HEULE Representative _____

Date _____

Customer _____

Contact person _____

- Request for quote
 Request for test tool
 Technical support
 Feasibility study

Workpiece Configuration

Ref.: Workpiece description _____

Please check correct application and fill in all values.

Drawing Nbr. _____

- Deburr
 Chamfer
 Countersink
 Combi

Application and Workpiece Information (Material, surface, hardness)

Production Information

Production volume per year		Sequence of production 1=Drill, 2=Ream, 3=Tap, 4=Back spot face, 5=Chamfer + Deburr
Cycle time		
Machine used	<input type="checkbox"/> CNC <input type="checkbox"/> Others	IC pressure

Tooling Information

Shank type	<input type="checkbox"/> Direct adaption	Internal coolant	<input type="checkbox"/> Yes	<input type="checkbox"/> No	External coolant	<input type="checkbox"/> Yes	<input type="checkbox"/> No
	<input type="checkbox"/> Cylindrical shank						
	<input type="checkbox"/> Weldon						
	<input type="checkbox"/> Whistle Notch						

Existing Solution (Description & intention: revise existing solution, new development, manual process, competitor product in use)

Problem definition/description (Please specify all important aspects of your application and send us the official application drawing.)

Comparable, existing Tool Solution

Tool Part Number _____

Blade Part Number _____

Customer _____

Similar to project nbr. _____

Table of Contents

Overview	
HEULE - We reduce your process times	3
A Global Leader - Our strength lies in problem solving	5
The HEULE Service - Worldwide on-site support	7
Our Market Expertise	9
Applications / Products Chart	10
Our Productivity Boosters - Product overview	13
Application Data Sheet for customer-specific tool	254
COFA	16
Characteristics and Advantages	19
Applications and Typical Workpieces	21
Tool Description	22
Function Principle / Process Steps Description	23
Product Selection	
Range Summary	24
Tool Part Numbers COFA	25
COFA C2 Tool Ø 2.0 to 3.1 mm	26
COFA C3 Tool Ø 3.0 to 4.1 mm	28
COFA 4M Tool Ø 4.0 to 5.1 mm	30
COFA 5M Tool Ø 5.0 to 6.1 mm	32
COFA C6 Tool Ø 6.0 to 8.4 mm	34
COFA C8 Tool Ø 8.0 to 12.4 mm	36
COFA C12 Tool Ø 12.0 to 26.0 mm	38
COFA C20 Tool	41
COFA Thread Series M8 to M20	42
COFA Cassette Systems C6 to C12	44
Installation Instructions for COFA Cassette	46
Technical Information	
Cutting Data COFA	48
Programming Information COFA	49
Blade Change COFA C2 / C3	50
Blade Change COFA 4M / 5M	51
Blade Change COFA C6 / C8 / C12	52
Accessories - Assembly Aid for Blade Change	53
Maximum Slope	54
Blade Dimensions COFA C6 – C12	56
FAQ	57
SNAP	58
Characteristics and Advantages	61
Applications and Typical Workpieces	63
Tool Description	64
Function Principle / Process Steps Description	65
Product Selection	
Range Summary	66
Tool Part Numbers SNAP	67
SNAP2 Tool Ø 2.0 mm to 2.9 mm	68
SNAP3 Tool Ø 3.0 mm to 3.9 mm	70
SNAP4 Tool Ø 4.0 mm to 5.0 mm	72
SNAP5 Tool Ø 5.0 mm to 10.0 mm	74
SNAP8 Tool Ø 8.0 mm to 12.0 mm	76
SNAP12 Tool Ø 12.0 mm to 20.0 mm	78
SNAP20 Tool Ø 20.0 mm to 35.0 mm	80
SNAP Thread Tool M2.5 / M3 / M4 / M5	82
SNAP Thread Tool M6 / M8 / M10 / M12 / M14	84
SNAP Cassette Systems SNAP5 / SNAP20	86
Installation Dimensions SNAP Cassette	88
Comparison GS / DF Blade Geometries	90
Technical Information	
Cutting Data SNAP	94
Programming Information SNAP	95
Adjusting the Chamfer Size / Setting the Blade Force	96
Blade Change SNAP2 / SNAP3 / SNAP4	97
Blade Change SNAP5 / SNAP8 / SNAP12 / SNAP20	98
Spare Parts	99
Blade Dimensions	102
FAQ	105
DEFA	106
Characteristics and Advantages	109
Tool Description	110
Function Principle	110
Process Steps Description	111
Product Selection	
Range Summary	112
Tool Part Numbers DEFA	113
DEFA Chamfering Tools 4-6	114
DEFA Chamfering Tools 6-10	116
DEFA Chamfering Tools 9-24	118
Technical Information	
Cutting Data DEFA	120
Programming Information DEFA	121
Setting the Blade Force	122
Setting the Chamfer Size	122
Blade Change	124
Spare Parts	125
Blade Dimensions	126
Comparison DF / DR Blade Geometries	128
Dimensions of Shanks and End Plugs	129
BSF	130
Characteristics and Advantages	132
Tool Description / Blade Working Principle	133

Table of Contents

Maximum Slope	134
Product Selection	
Range Summary	135
Tool Part Numbers BSF	136
BSF Tool for Bore Ø 6.5 bis 7.0 mm	137
BSF Tool for Bore Ø 7.5 bis 8.5 mm	138
BSF Tool for Bore Ø 9.0 bis 10.0 mm	140
BSF Tool for Bore Ø 10.5 bis 11.5 mm	142
BSF Tool for Bore Ø 12.0 bis 14.0 mm	145
BSF Tool for Bore Ø 14.5 bis 17.0 mm	150
BSF Tool for Bore Ø 17.5 bis 21.0 mm	156
Tool Selection for Socket Head Cap Screws C'bores	166
Technical Information	
Machine Parameters - Minimum Requirements	166
Cutting Data BSF	167
Activation Speed	168
Drawing Application Parameters	169
Application and Ordering Example	170
Programming Information BSF	171
Blade Change	172
Spare Parts	173
Blade Dimensions	179
FAQ	180
SOLO	182
Characteristics and Advantages	185
Tool Design	187
Tool Description	188
Function Principle	189
Product Selection	
Range Summary	190
Version with large Adaption	191
Version with Guide Bushings	192
Order Data - Required Application Data	193
Technical Information	
Cutting Data SOLO	194
Countersinking Tolerance	195
Programming Information SOLO	196
Programming Information SOLO2	197
Blade Change	198
Change of Blade Housing and Blade Control	199
Maintenance Intervals / Services	200
Function Check	201
GH-K	202
Characteristics and Advantages	205
Tool Description	206
Product Selection	
Range Summary	206
GH-K Tool with 3 Blades	207
GH-K Tool with 1 Blade	208
Technical Information	
Cutting Data GH-K	209
Accessories – Sharpening Device	209
VEX	210
Characteristics and Advantages	213
Tool Description	214
Function Principle / Process Steps Description	215
Product Selection	
Range Summary	216
Tool Part Numbers VEX System	217
VEX Combi Ø5.0 to 11.0 mm w/o IC, Bore Depth 1xd	218
VEX Combi Ø6.0 to 11.0 mm with IC, Bore Depth 1xd	220
VEX Combi Ø5.0 to 11.0 mm w/o IC, Bore Depth 2xd	222
VEX Combi Ø6.0 to 11.0 mm with IC, Bore Depth 2xd	224
Technical Information	
Cutting Data VEX	226
Programming Information VEX	227
Application Range	228
Cooling	229
FAQ	229
Assembly / Dismantling of VEX Drill Bit	230
Re-grinding	231
Spare Parts	232
SNAP Chamfering Blades	234
Function Principle	234
Blade Change	234
Blade Geometries	235
Cutting Data SNAP5 GS Geometry	235
SNAP5 Blades GS Geometry 90° for VEX Combi	236
Adjusting the Chamfer Size	237
Setting the Blade Force	237
X-BORES	238
Application / Product Diagram	240
COFA-X	242
SNAP-X	246
CBD	250



Efficient and reliable.

Our solutions reduce your production costs.

Deburring

- COFA
- SNAP
- X-BORES

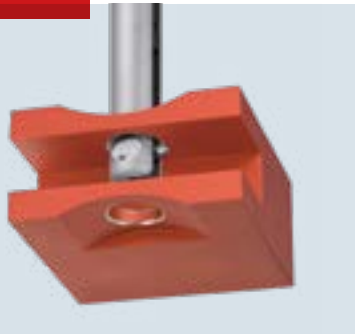

Chamfering

- SNAP
- DEFA

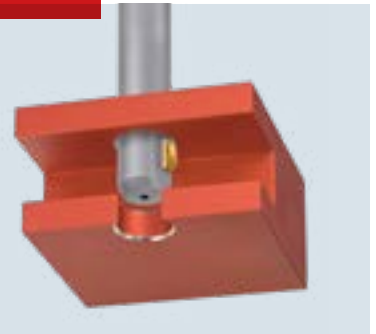

Countersinking

- BSF
- SOLO
- GH-K



Drilling and Chamfering

- VEX



HEULE+
PRECISION TOOLS

Headquarters: HEULE Werkzeug AG, Balgach / Switzerland, Tel. +41 71 726 38 38, info@heule.com, www.heule.com

Subsidiaries: HEULE Tool Corp., Loveland/OH, USA, Tel. +1 513 860 9900, info@heuletool.com, www.heuletool.com
HEULE Precision Tools (Wuxi) Co. Ltd., Wuxi / China, Tel. +86 510 8202 2404, china@heule.cn, www.heule.cn
HEULE Korea Co. Ltd., Gyeonggi-do / South Korea, Tel. +82 31 8005-8392, info@heule.co.kr, www.heule.co.kr
HEULE Germany GmbH, Wangen/Allgäu, Tel. +49 7522 99990-60, info@heule.de, www.heule.de

Representatives: 50 agents in 35 countries worldwide – Please visit www.heule.com >Service >Contact Sales Representatives